

Table of Contents

Subject	Page
Body - Convertible Top2
Objectives of the Module2
Convertible Top Features3
Top Construction4
System Operation Description6
Hydraulics7
Electrical System Operation8
Emergency Closing Operation10
Review Questions11

BODY

Convertible Top

Model: E52

Production Date: 03/00 To Present

Objectives of the Module

After completing this module, you will be able to:

- Describe the lowering and raising sequence of the convertible soft top in detail.
- Name the functions and locations of the convertible top sensors.
- Identify and describe the hydraulic components used in the convertible top.
- Describe the windshield frame latching assembly.
- Describe and perform the convertible top emergency operation.

Convertible Top

Purpose of The System

The Z8 Convertible top is a semi-automatic electro-hydraulic system that opens and closes the soft top using hydraulic cylinders and an electric motor. It consists of the convertible module (CVM) which monitors and controls the complete operation of the soft top system. The CVM interacts with the General Module which controls the window operation when lowering or raising the soft top. A hard top is standard equipment.

Convertible Top Features

- Electro/Hydraulic Operation
- Servo Assisted Electric Lock
- Flexible, Easy to Replace Rear Window (Zip Out)
- Inner Headliner
- Emergency Operation

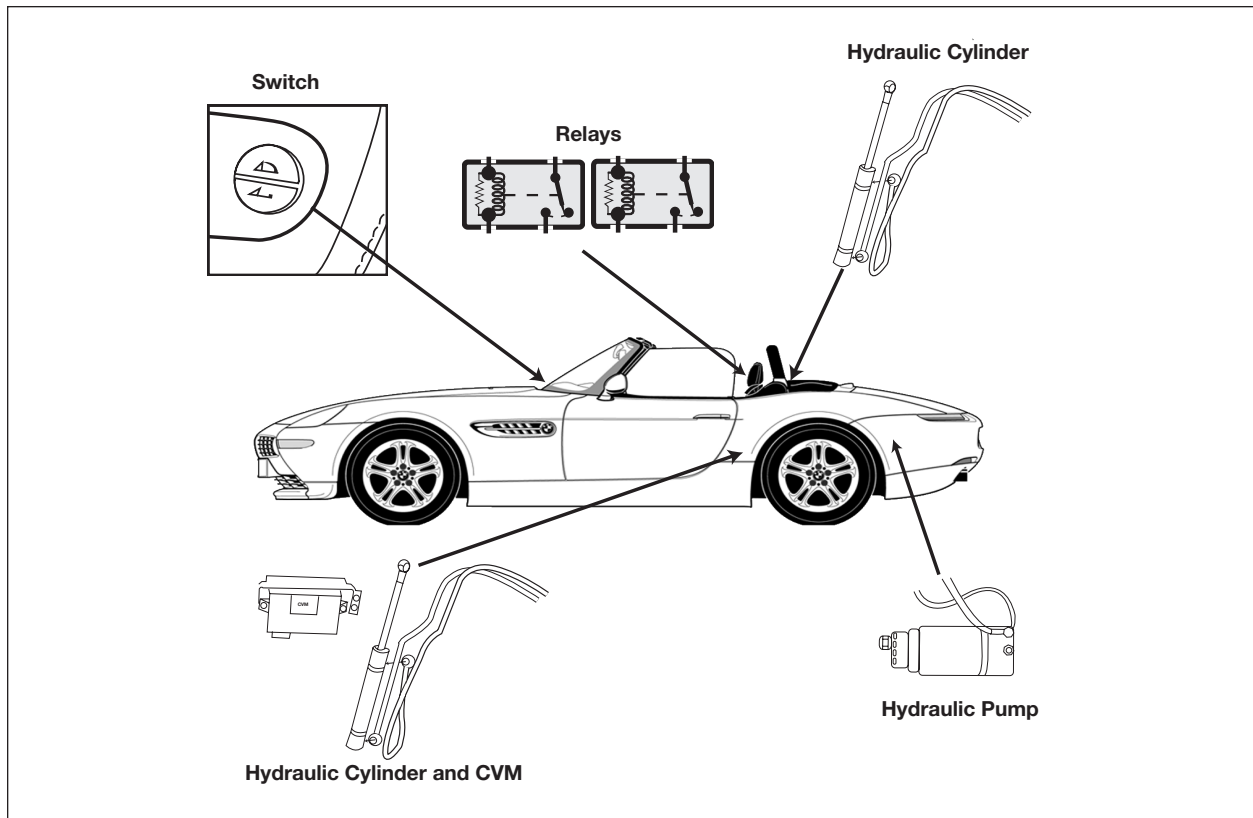

Top Construction

Top and Frame

The convertible top consists of *three layers*:

The **outer layer** is fabric with a replaceable (zip-out) rear window.

A **middle fleece liner** is installed between the fabric and inner liner for sound and weather insulating purposes.

To assist the frame in tensioning when the top is closed, the top has tensioning straps and cables for additional support, which is indicated by the arrows on the right.

The **inner liner** is similar to the E46iC and is attached to the top frame so that it stretches tight when the top is closed.

The pull handle with integral Hall sensor which is (required for the final closing procedure) is also shown on the right.

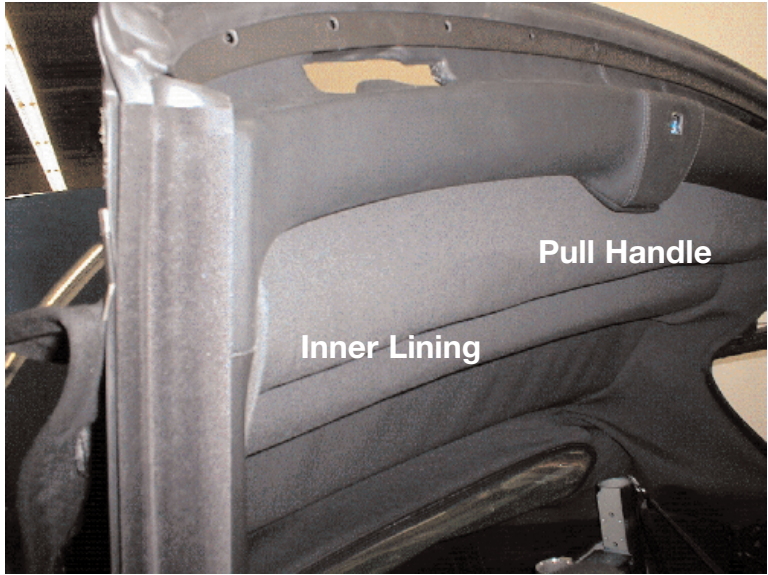
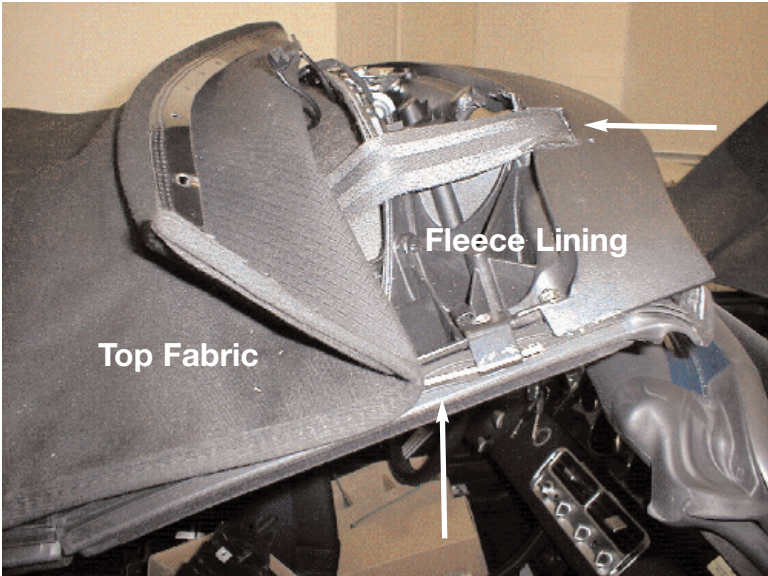

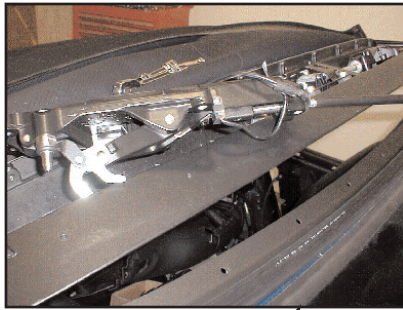

Latching Assembly

Underneath the fabric, the front bow houses the latching assembly. This assembly consists of a drive motor, closing handle (hall sensor) and two mechanical latches. The right hand latch consist of three hall sensors.

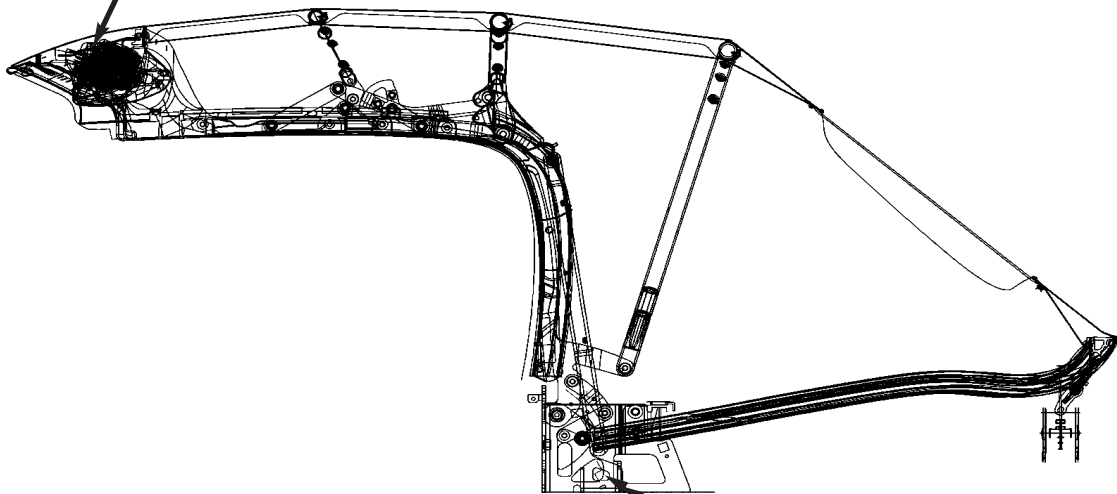

The left rear hinge assembly contains two hall sensors for top up/down recognition.

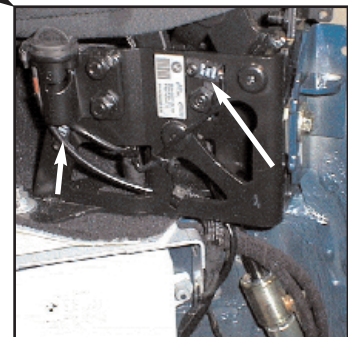

Hall Sensors

Pre-Conditions for Soft Top Operation

- Ignition switched on
- Vehicle stationary (0 road speed)
- Switch must be continually pressed

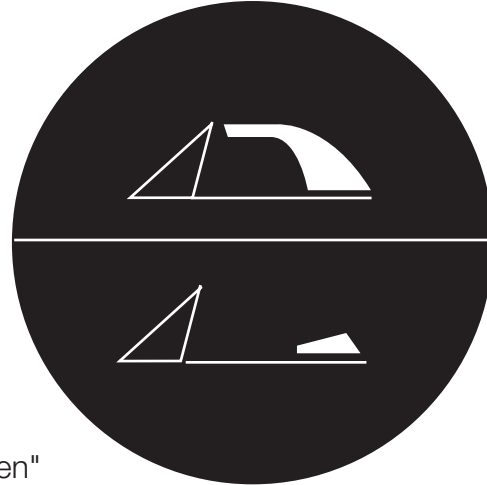

Procedure To Open The Top

- Press and hold convertible top switch to "open"
- Windshield latch is released automatically
- The side windows are lowered (via K-bus to GM V)
- The convertible top is lowered into the convertible top compartment
- Sound system is automatically equalized (road noise compensation)
- Windows will raise if the switch is continually pressed after the top is stored

Procedure To Close The Top

- Press and hold convertible top button to "close"
- The side windows are lowered (via K-bus to GM V)
- The convertible top is raised out of the convertible top compartment
- Release "close" convertible top button
- Squeeze/pull the recessed handle (windshield latches lock the bow)
- Windows will raise if the squeeze/pull handle is continually pressed after the top is raised

Hydraulic Unit

The hydraulic unit is a self contained unit with a sealed reservoir that is sleeved around the pump assembly.

The end of the hydraulic unit contains a distribution block where the hydraulic lines are fitted.

The hydraulic unit is located in the left rear fender well.

The pump motor is controlled by the CVM III.

The CVM III simply reverses the polarity (through the relays) to reverse the pump motor operation.

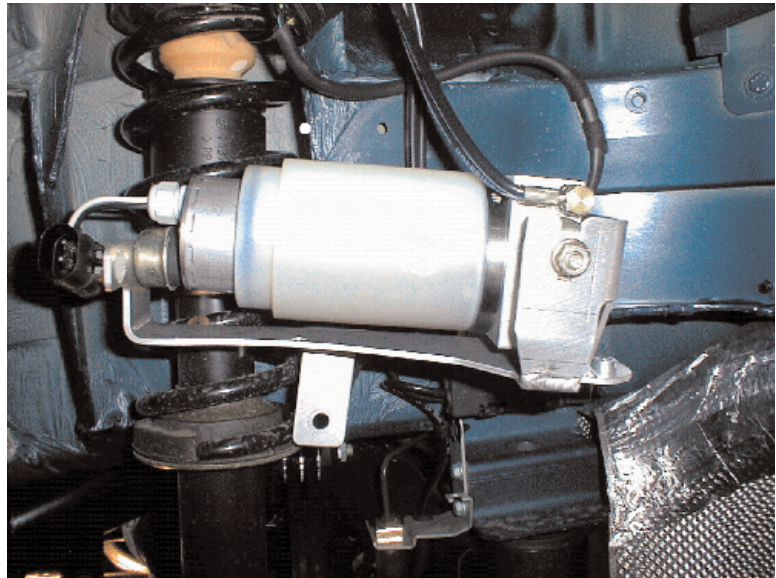

Hydraulic Cylinders

The convertible top is operated by two hydraulic cylinders (which reduces stress from the top frame).

They are located behind each seat under the rear interior trim panels.

The hydraulic lines are routed into the body behind the driver's seat.

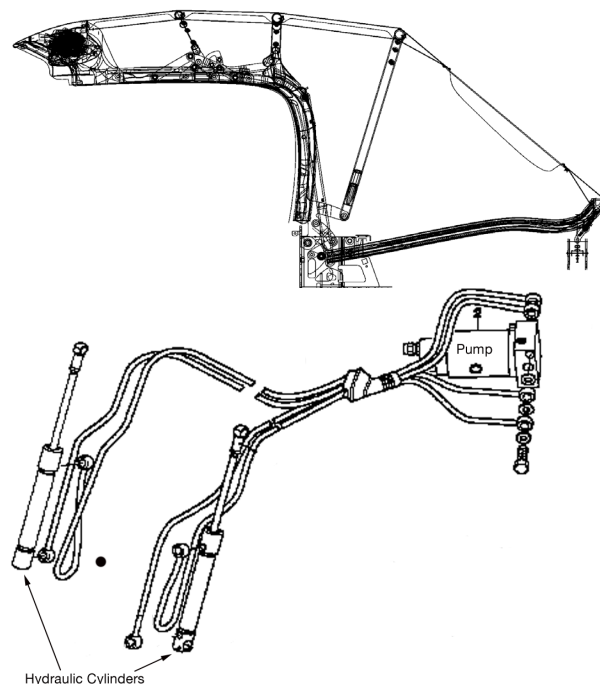

System Operation

Electrical Operation

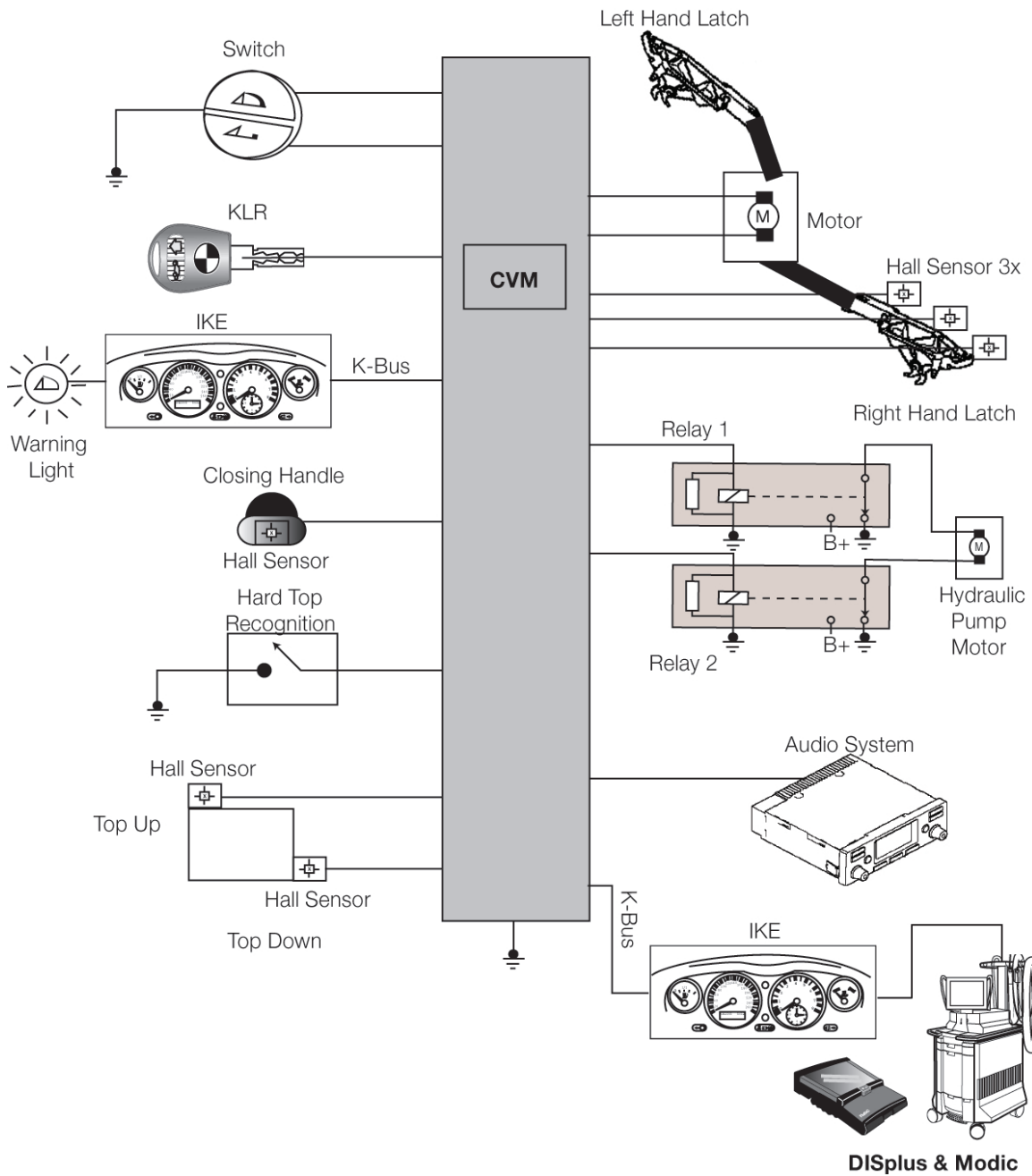

Electrical Operation

Top Operation

The convertible top operation is controlled by the Convertible Top Module (CVM III). The control switch is located in the center console, next to the shift handle. During operation the convertible top warning light will be “on”. If the top is stopped in mid operation, or if a fault occurs, the warning light will “flash”. The top will not operate if there is road speed present.

Top Lowering Sequence

Top Switch Pressed “Open”

- The CVM activates the latching drive motor, which releases and open the latches.
- The latch hall sensor confirms the release of the latches by sending a signal to the CVM.
- The CVM signals the GM to lower the windows (if closed) for approx. 1.5 sec.
- The CVM activates the pump motor relay (1) and the hydraulic pump pressurizes the hydraulic cylinders to pull the soft top open.
- The soft top will then be folded into the storage compartment.
- When the soft top is in the storage compartment, the Top-down hall sensor signals the CVM to deactivate the hydraulic pump.
- The CVM will then activate the latching drive motor to “fold in” the latches.

Top Raising Sequence

Top Switch Pressed “Closed”

- The CVM activates the latching drive motor, which releases and opens the latches.
- The latch hall sensor confirms the release of the latches by sending a signal to the CVM.
- The CVM activates the pump motor relay (2) and the hydraulic pump runs in the reverse direction, pressurizing the hydraulic cylinders to raise the soft top frame.
- The soft top is raised to the point that the Top-up hall sensor signals the CVM to stop the pump motor.
- At this point the soft top is slightly open, the driver must reach into the recessed handle and squeeze and pull down at the same time.
- The pull handle hall sensor will trigger the CVM to activate the latching drive motor to lock the top frame/bow to the windshield frame.

Emergency Closing Operation

- In the event of an electric/hydraulic malfunction, the top can be raised manually
- To raise the top, the bow latches must be released
- Remove the access cover from the inner bow cover, and using the tool from the tool kit, manually crank the bow latches open.



- Once the latches have been fully released, the top can be manually raised (the latches will then need to be manually latched) - a slight bleed off time is required
- The convertible top can not be manually lowered
- This system does not require an initialization after the emergency procedure has been performed

Review Questions

1. In the event of a malfunction, how is the convertible top manually raised?

2. What hydraulic components are used for the convertible top operation?

3. What other systems interact with the CVM and why?
