Table of Contents

SMG II

Subject	Page
Purpose of System	3
System Components	4
Basic Gearbox.....	5
SMG II Control Unit	5
IPO	6
SMG II Input/Outputs	7
DME MS S54	10
Hydraulic Unit	10
Hydraulic Diagram	14
Gearbox Actuator	16
Clutch Slave Cylinder	18
Shift Lever	18
Steering Wheel Paddle Switches	20
DRIVELOGIC Control	20
SMG II Electronic Display Unit	21
Shift Lights	22
DSC Control Unit	22
SAC Clutch	22
Principle of Operation	23
Engine Starting	23
Engaging a gear	23
Upshifts and Downshifts	27
Shifting Operation	28
Driving and Shift Programs	28
A-Mode	29
S-Mode	32
Other Shift Functions	34
Safety Functions	34
SMG II Diagnosis	36
Review Questions	38
Fault Codes	39

SMG II

Model: E46 M3 SMG II

Production: Available 1/02 USA

Objectives:

After completion of this module you should be able to:

- Understand the SMG II operating modes.
- Recognize and locate the components of the SMG II.
- Understand operation of the SMG II
- Diagnose the SMG II.

Purpose of the System

SMG II

The SMG II combines the six-speed manual gearbox (S6S420G) of the E46 M3 with computer-controlled electrohydraulic clutch and gear change operation. The driver is provided with the accuracy of manual gear selection, the convenience of automated shifting and the speed and adaptability of driver-adjusted computer control.

Using technology developed for the BMW/Williams Formula 1 car, the SMG II with DRIVELOGIC adapts the speed, accuracy and control of the race cars electrohydraulic shifting to the M3.



1. Shift Lever
2. DRIVELOGIC Control
3. Shift Paddles
4. Missing Clutch Pedal

Shift Lever and Paddles

45-01-01

Features of the SMG II include:

- Two operating modes
 - Manual, shift lever or the steering wheel mounted paddle switches are used to make gear changes. (S-Mode)
 - Automatic, gear selection and shifting provided by the SMG II. (A-Mode)
- DRIVELOGIC control to adjust shift programs in the A mode or shift dynamics in the S Mode.
- Light weight and elimination of torque convertor when compared to an Automatic Transmission.
- Same basic 6 speed gear box design as Non-SMG II equipped M3.
- Elimination of clutch pedal.
- Adaptable based on engine torque and speed.

System Components

The SMG II system is consists of the following components:

- Basic Gearbox (S6S420G, Getrag type D)
- SMG II Control Unit (Siemens)
- SMG CAN Bus
- DME Control Unit (MSS54)
- Hydraulic unit and solenoids
- Gearbox Actuator
- Clutch Slave Cylinder with PLCD (Permanent Linear Contactless Displacement)
- Shift Lever Module with Shift Lock
- Steering Wheel Paddle mounted switches
- DRIVELOGIC Control
- Display in instrument cluster
- DSC control unit
- SAC dry single disc clutch

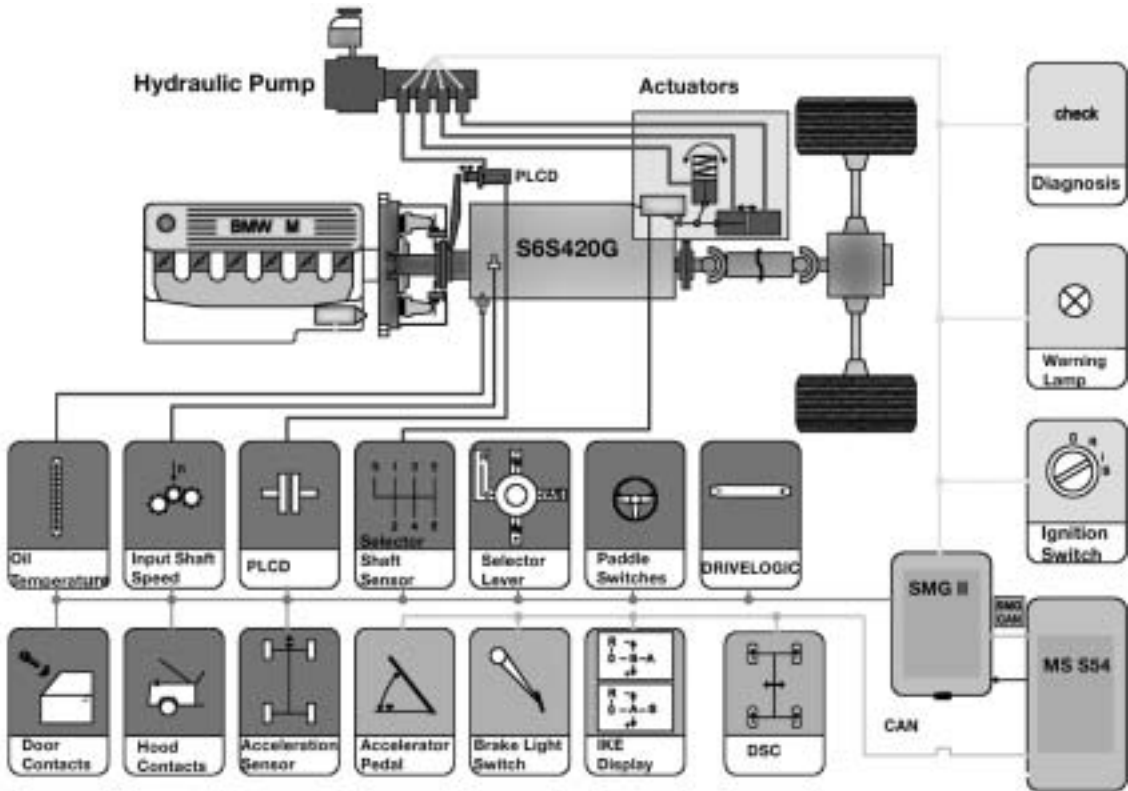

SMG II System Schematic

45-02-2A

Basic Gearbox

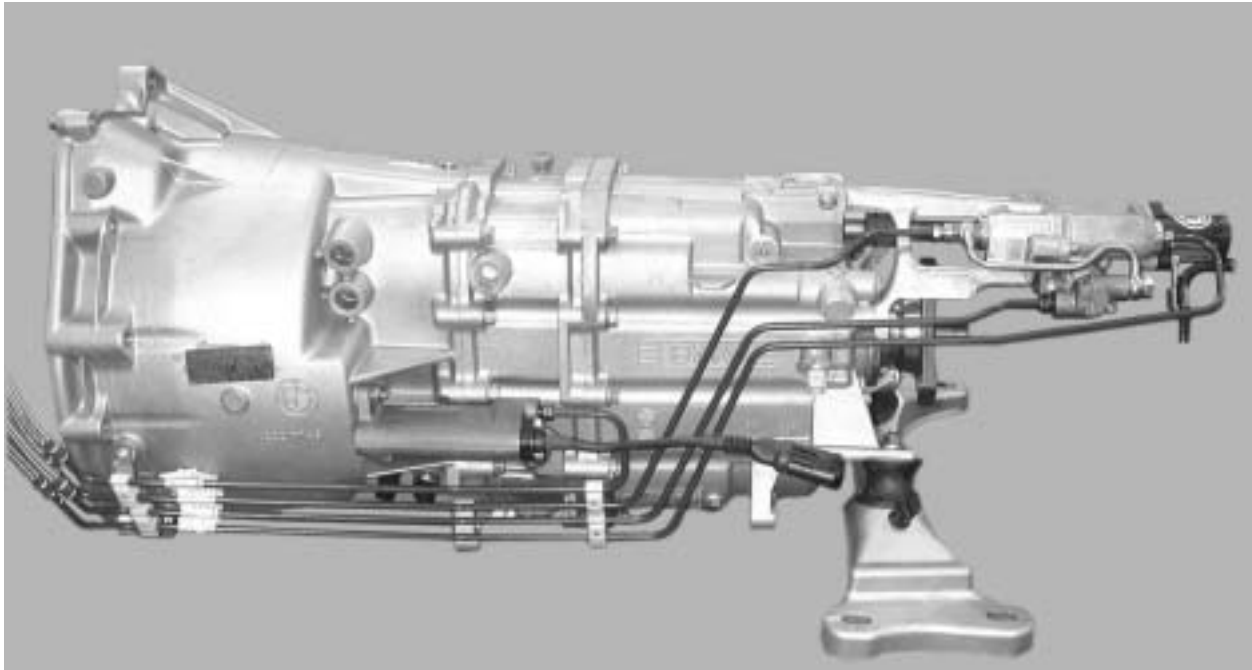

SMG II Manual Gearbox

45-01-03

The standard basic gearbox (S6S420G), as used in the M3, is transformed into a sequential gearbox with the addition of a hydraulic unit and shift assembly, a special clutch slave cylinder and a new shift-lever module.

SMG II Control Unit

The SMG II Control Unit, installed in the E-Box next to the DME, is a single board module with SKE (134 pin) gray colored connectors. The unit contains protection against reverse polarity and overvoltage.

Communication with the DME is via a dedicated CAN bus (SMG II CAN Bus). Based on instructions received from the DME the SMG II control unit manages the clutch solenoid valve, the selector shaft up and down solenoids, and the selection angle solenoid. Safety functions and limp home capabilities are also part of the SMG II programming.

While the SMG II control unit receives many of the inputs and manages the control of the hydraulic system, the DME is responsible for and controls all gearshifts. Sensor inputs received by the SMG II control unit are relayed to the DME for processing and monitoring.

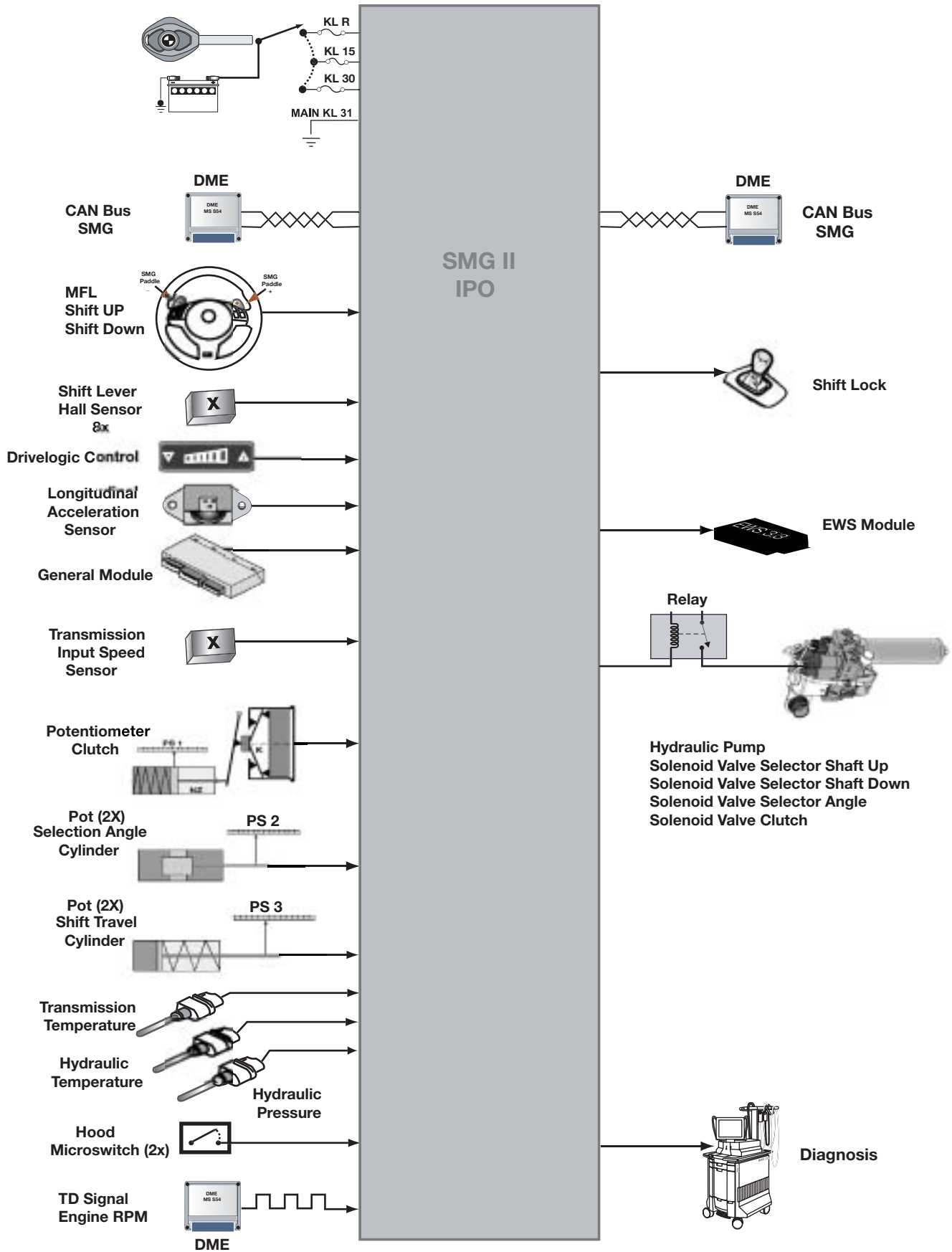

SMG II Control Unit Inputs/Outputs

SMG CAN Bus

The SMG CAN Bus is the link for signal exchange between the DME and SMG II Control Unit. It allows the DME to issue command instructions for clutch and gearbox control as well as shift sequence and enables SMG II communication with the vehicle CAN BUS via the DME.

Signals exchanged via SMG CAN Bus:

Engine Speed	Engine Coolant Temp	Engine Oil Temp
Intake Air Temp	PWG	EDR Feedback Pots
Wheel Speed	Transverse Acceleration	Steering Angle
Cruise Status	Parking Brake	Door Contacts
Brake Light Switch	Key Memory	

Engine Speed

The engine speed signal is transmitted twice to the SMG II control unit. One signal arrives via the SMG CAN, the other arrives via a hard wire from the DME.

Engine Coolant Temp

Engine Oil Temp

Intake Air Temp

The signals are inputs directly into the DME and are shared with the SMG II control unit as the information is needed over the SMG II CAN.

PWG

The PWG signal is input into the DME and forwarded to the SMG II control unit. The information is used to calculate engine load.

EDR Feedback Pots

These potentiometers provide throttle position information that is useful during slip intervention.

Wheel Speed

Conditioned digital wheel speed information is received from the DSC control unit. The SMG II control unit uses data from all 4 wheels to detect vehicle speed and wheel slip in the A-Mode and during down shifts in all modes to detect drag torque induced wheel slip.

Transverse Acceleration

Transverse Acceleration data is transferred from the DSC control unit in the A-Mode so that up and down shifts may be prevented during high speed cornering. This sensor information is further evaluated for slip recognition purposes.

Steering Angle

This data from the steering angle sensor is sent via the CAN Bus for cornering and slip control information.

Cruise Status

The cruise mode is deactivated when a driver initiated shift is made in the S-Mode, during A-Mode operation, the cruise control setting is maintained.

Parking Brake

Information concerning parking brake application affects gear engagement and vehicle operation.

Door Contacts

The hall effect door position sensors integrated into the door latch mechanism signal the GM. This data is transferred via the K-Bus and CAN Bus for safety program initiation.

Brake Light Switch

Brake pedal status is transferred to the SMG II control unit via the DME. The signal is used for:

Unlocking the shift lock	Brake detection	Engine Starting
Downhill detection	Clutch Disengagement while stopped.	

Key Memory

At this time no functions for Car or Key Memory are provided for SMG II

SMG II Control Unit Inputs

MFL

Upshift and downshift signals from the paddle switches located on the steering wheel.

Shift lever

Located in the shift lever module, 8 hall sensors detect upshift and downshift requests and are also used for Selector Lever position indication (Forward, Reverse and Neutral). Signals from the hall sensors are also used to initiate mode changes from S-Mode to A-Mode and back.

DRIVELOGIC

The shift characteristics are activated by means of the switch located on the console just to the rear of the shift lever.

Longitudinal Acceleration

The signals from the Longitudinal Acceleration Sensor which is mounted under the passenger seat are used for uphill driving programs.

General Module

Load deactivation information (Sleep) is received by the SMG II Control Unit.

Clutch Position

Input from the PLCD providing exact clutch position.

Shift Position

The Position sensor provides two inputs (PS2 and PS3, each a dual pot) for position recognition of the main selector shaft in the transmission.

Gearbox RPM

A hall sensor is used to measure transmission input shaft speed.

Hydraulic Pressure

A Pressure transducer for monitoring hydraulic pressure sends pressure information to the SMG II Control Unit.

Temperature Sensors

Two NTC sensors are used for measuring Gearbox oil temperature and hydraulic fluid temperature.

Hood Contacts

Two Micro switches located in the hood latch mechanism provide a ground signal to the SMG II Control Unit when the hood is closed.

Engine Speed

Calculated engine speed received from DME via hardwire serves as redundant information with that received via the SMG CAN Bus.

SMG II Control Unit Outputs

Shift Lock Mechanism

The Shift Lock Mechanism locks the shift lever in position for parking and prevents unintended gear changes as part of the safety programming.

EWS

During the start-up operation, the SMG II Control Unit confirms shift lever position (0) and brake application and signals the EWS module which then allows starter engagement.

Hydraulic Unit

The Hydraulic Unit is energized through a relay controlled by the SMG II Control Unit. The operation of four (4) solenoid valves located in the hydraulic unit that are used to actuate the clutch and shift the transmission are also controlled by the SMG II.

DME Control Unit MS S54

Programming in the MS S54 controls the shift sequence through the SMG II CAN Bus interface with the SMG II control unit.

Hydraulic Unit

The Hydraulic Unit generates the oil pressure and controls the shifts. It is mounted under the intake manifold in the area of the starter motor.

The hydraulic unit is filled with .45 L Pentosin CHF 11S fluid and operates at a working pressure of 45-80 Bar.

The hydraulic units consists of the following components:

- Aluminum Housing
- Electro-Hydraulic pump with filter
- 18 pin electrical connector
- Pressure accumulator and non-return valve
- Pressure relief valve
- Oil pressure sensor
- Oil temperature sensor
- Fluid Expansion tank
- Proportional directional valve for clutch control
- Proportional directional valve for selector shaft angle control
- Pressure control valve for shift travel cylinder actuation

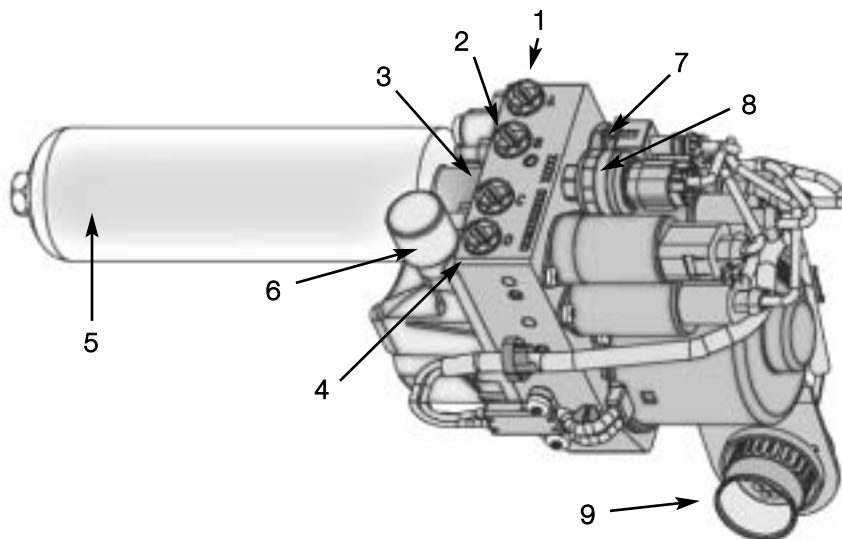

1. Hydraulic Line for Shift Travel 1 Gears 1,3,5.
2. Hydraulic Line Slave Cylinder Clutch Control.
3. Hydraulic Line for Selector Angle Control Cylinder.
4. Hydraulic Line for Shift Travel 2 Gears 2,4,6.
5. Pressure Accumulator.
6. Supply Line from Hydraulic Tank.
7. Hydraulic Fluid Temp Sensor
8. Hydraulic Fluid Pressure Sensor.
9. X 5330 18 Pin connector.

SMG II Hydraulic Unit

45-01-5A

Hydraulic Pump

The Hydraulic Pump, installed in the Hydraulic unit, generates the pressure required to operate the clutch and perform gear changes.

The pump is a piston pump driven by an electric motor, actuated by the SMG control unit via a relay so that oil pressure is always between 45 and 80 bar. Power consumption of the electric motor is 20 amps.

When the fluid pressure in the hydraulic unit drops below 45 bar, the SMG II control unit activates the relay and supplies the electric motor with B+. At a hydraulic pressure of 80 bar, the SMG II control unit deactivates the relay.

To ensure there is sufficient pressure when the engine is started, the hydraulic pump is activated below an accumulator pressure of 45 bar when the door is opened or the vehicle is unlocked with the key or the remote.

In the event of a hydraulic system failure the gearbox warning lamp is turned on in the IKE and if hydraulic pressure fails to build, no further gearshifts are allowed. This allows the reserve pressure in the accumulator to be used to place the gearbox in the Neutral position when the vehicle comes to a stop.

Pressure Accumulator and Non-Return Valve

The Pressure Accumulator in the hydraulic unit ensures that pressure generated by the pump is stored in the system for a certain amount of time. The accumulator is divided into two chambers by a piston, with nitrogen at 39 bar filling one chamber and fluid delivered by the hydraulic pump filling the other chamber. The volume of the accumulator is 150ccm. The Non-Return Valve at the pump outlet prevents the hydraulic oil pressure from dropping when the pump is not running.

Pressure Relief Valve

The Pressure Relief Valve opens if the hydraulic oil pressure reaches 100 bar, creating a circuit between the suction and pressure sides of the pump, thus preventing further increase in pressure.

Hydraulic Oil Pressure Sensor

Mounted on the hydraulic unit the Oil Pressure Sensor informs the SMG II control unit of the current hydraulic pressure. At 0 bar pressure a voltage signal of .5 volts is sent to the SMG II with the voltage increasing linearly to 4.58 volts at 100 bar of pressure.

Failure of the pressure sensor whether shorted or open will result in the hydraulic unit being activated for a fixed amount of time at predetermined intervals and after each gearshift to maintain system pressure.

Hydraulic Oil Temperature Sensor

Temperature of the hydraulic oil is monitored by the SMG II control unit via a NTC temperature sensor located in the hydraulic unit.

Hydraulic Fluid Expansion Tank



45-01-06

Hydraulic Fluid Expansion Tank Mounting



45-01-09

Hydraulic Fluid Expansion Tank Quick Release Coupling.

The Hydraulic Fluid Expansion Tank is mounted on the rear of the intake manifold and connected to the hydraulic unit via a plastic supply hose with a quick release coupling. A valve in the tank prevents oil loss when the supply hose is disconnected.

Solenoid Valves

Four solenoid valves are installed in the hydraulic unit. Two of the solenoid valves are designed as proportional directional valves (1- for clutch control and 1- for selection angle cylinder actuation). The other two solenoid valves are pressure control valves (both used for shift travel cylinder actuation).

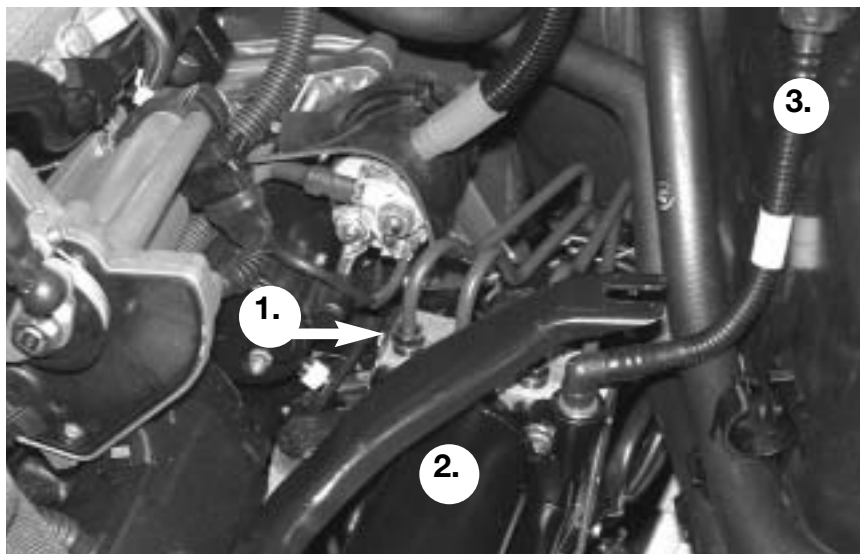

1. Hydraulic lines at solenoids
2. Accumulator
3. Supply Line from Expansion Tank

45-01-09

Hydraulic Unit in vehicle with intake manifold removed

Proportional Directional Valves

The two proportional directional valves have three positions: pressure reduction, pressure holding, pressure increase.

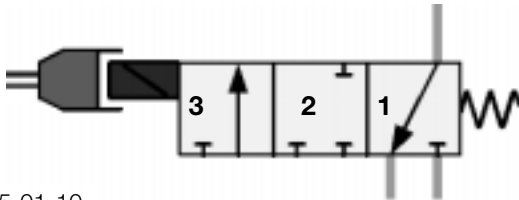

1. Pressure Reduction
2. Pressure Holding
3. Pressure Increase

45-01-10

Proportional Directional Control Valve

The proportional directional valves are set in the **pressure reduction position** when there is no gear shifting or clutch operation in progress. In this condition the two cylinders (clutch cylinder and selector angle cylinder) are connected to the expansion tank.

During clutch operation or main selector shaft rotation the valve is placed in the **pressure increase position**. In this position the valve connects the cylinder to the hydraulic pressure accumulator. At this stage the solenoid will consume approximately 1.1 - 2 amps. The valve is fully open up to 2 amps.

When the clutch is to be disengaged or the main selector shaft is to remain in the activated position, the valve switches to the **pressure holding position**. With the valve in this position the flow of hydraulic oil to the cylinder is interrupted and the piston of the activated cylinder remains in a pressurized mode.

Pressure Control Valve

The piston in the shift travel cylinder must be moved in both directions (in/out) by pressure. Two pressure control valves are required to achieve this movement.

With no current applied to the valves they are in the open position allowing connection of the cylinder chamber and the expansion tank. Applying current to one of the solenoids will cause hydraulic fluid to flow against the cylinder piston pushing it in one direction. Fluid from the other side of the piston will be forced through the second control valve into the expansion tank.

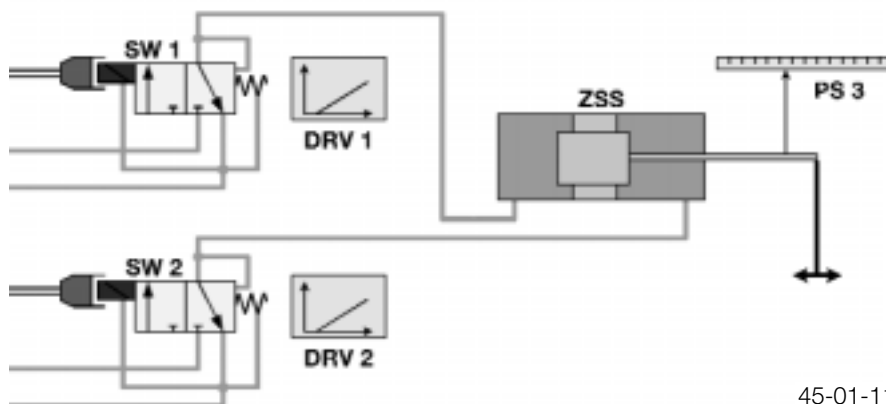

- SW1 - DRV1
Pressure Control Valve
- SW2 - DRV2
Pressure Control Valve
- ZSS
Shift Travel Cylinder
- PS3
Shift Travel Position Sensor

45-01-11

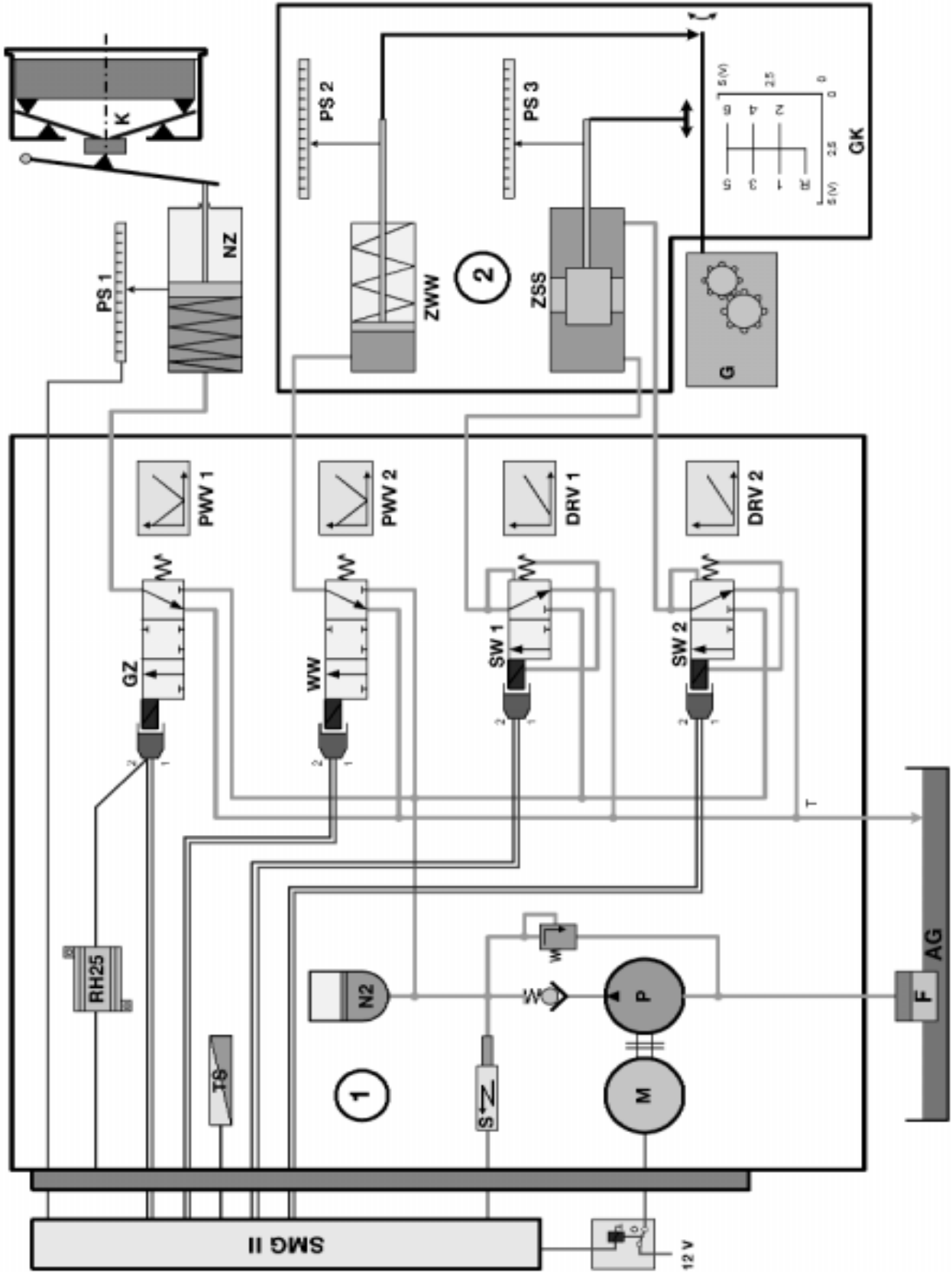

Index	Designation/Function	Location
1	Electro-Hydraulic Control Unit	On Engine Under Intake Manifold
2	Gearbox Mounted Actuator	Top of Box at Rear
G	Manual Gearbox	Normal Position
K	SAC (Self Adjusting Clutch)	Normal Position
SMG II	SMG II Control Unit (134 Pin SKE)	E-Box next to DME (Grey colored Connectors)
R	Relay	
12v	12V Power Supply	
RH25	4.7 Ω Resistor	
TS	Temperature Sensor	Internal in Hydraulic Control Unit
GZ	Proportional Directional Control Valve and Solenoid for Clutch	On Hydraulic Control Unit (See Page 9)
PWV 1	Control	In Hydraulic Control Unit
WW	Pressure control Valve and Solenoid for Selection Angle	In Hydraulic Control Unit
PWV2	Control	
SW1	Pressure control Valve and Solenoid for shift travel control	In Hydraulic Control Unit
DRV1		
SW2	Pressure control Valve and Solenoid for shift travel control	In Hydraulic Control Unit
DRV 2		
N2	Hydraulic Accumulator 39 Bar	In Hydraulic Control Unit
S	Hydraulic Oil Pressure Sensor (0-100 Bar) (.4V=25 Bar, 2.9V=60 Bar, 3.7V=80 Bar, 4.5V=100 Bar)	On Hydraulic Control Unit (See Page 9)
RS	Non-return Valve	In Hydraulic Control Unit
DBV	Pressure Relief Valve	In Hydraulic Control Unit
M	12V Electric Motor	In Hydraulic Control Unit
P	Hydraulic Pump	In Hydraulic Control Unit
F	Fluid Intake Filter	
AG	Expansion Tank	Mounted on Intake Manifold
PS1	Position Sensor, Clutch	Mounted on slave Cylinder
NZ	Clutch slave Cylinder	Normal Position
PS2	Position Sensor, Selection Angle Cylinder	Mounted on Gearbox Actuator
ZWW	Selection Angle Cylinder	In Gearbox Actuator
PS3	Position Sensor, Shift travel Cylinder	In Gearbox Actuator
ZSS	Shift Travel Cylinder	In Gearbox Actuator
GK	Gear Detection	

Gearbox Actuator

The Gearbox Actuator, manufactured by Getrag, is attached to the rear of the gearbox housing and performs the gear change movements.

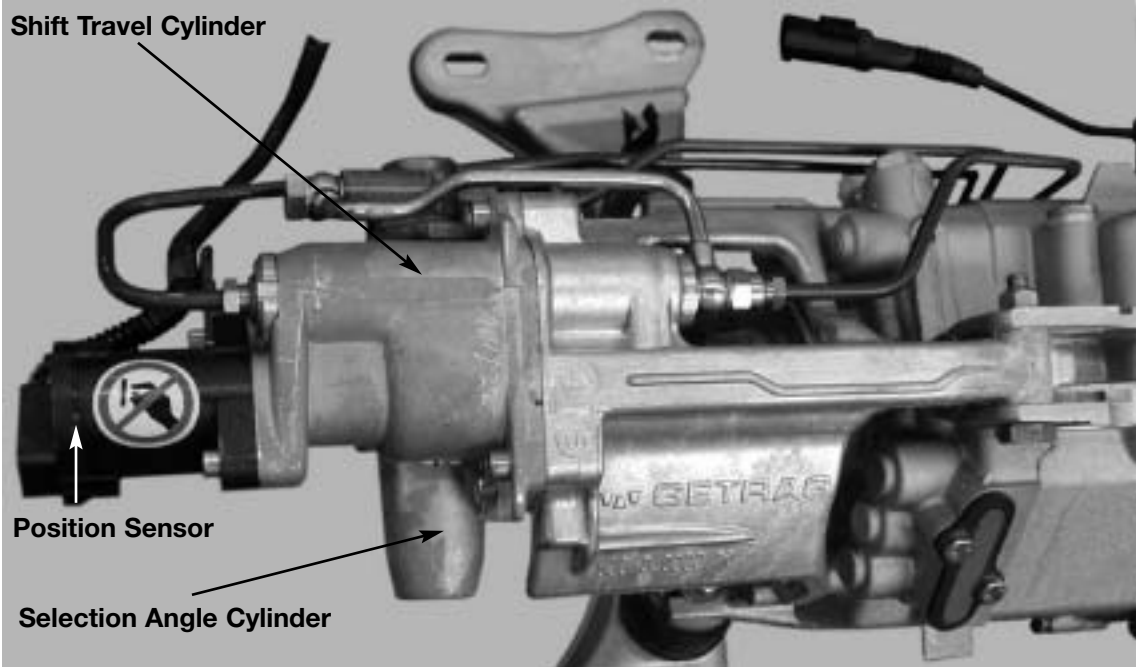

SMG II Gear Box Actuator

45-01-15

The gearbox actuator consists of the following components:

- Gearbox Actuator Housing
- Main Selector Shaft
- Position Sensor

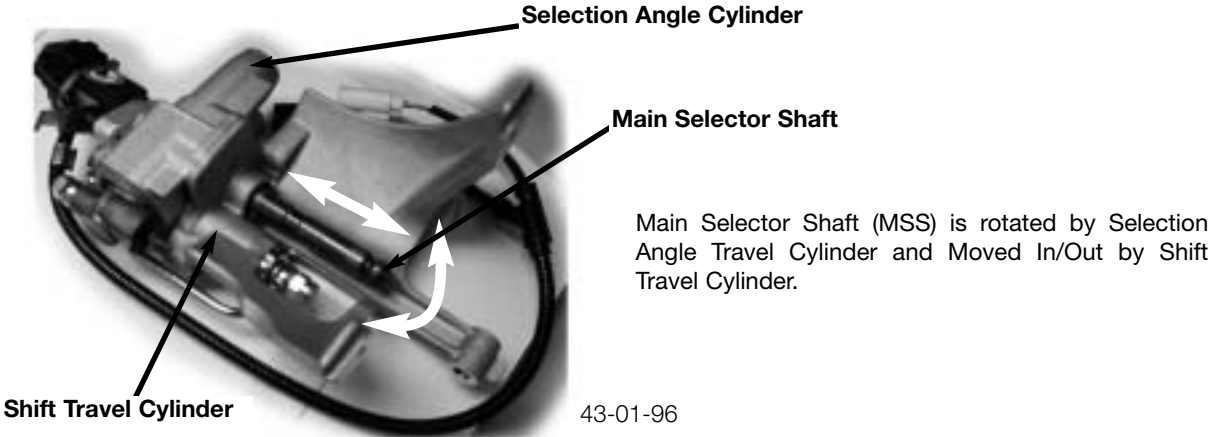

43-01-96

Gear Actuation

When no gear is engaged the selector shaft is in the neutral position in the shift gate between 5th and 6th gears. The piston in the selection angle cylinder (B) is pushed against the stop by a spring. The shift travel cylinder is in the central position in cylinder C (pressure is equal on both sides).

With the selection of 1st gear, the piston in the selection angle cylinder (B) is charged with hydraulic fluid (Pressure increasing mode). The SMG II control unit is informed by the position sensor (PS2) when the piston and consequently the main selector shaft (MSS) has reached the point in the shift gate between 1st and 2nd gears. The piston in the selection angle cylinder is placed in the pressure holding mode to maintain MSS position.

Shift Travel cylinder (C) is now activated via the control valves. One side of the piston in the cylinder is supplied with hydraulic fluid under pressure, the other side of the piston chamber is open to the expansion tank. The piston and with it the MSS is pushed in the appropriate position and a gear is engaged (Either 1st or 2nd). A redirection of fluid on the shift travel cylinder piston will cause the other gear to be engaged.

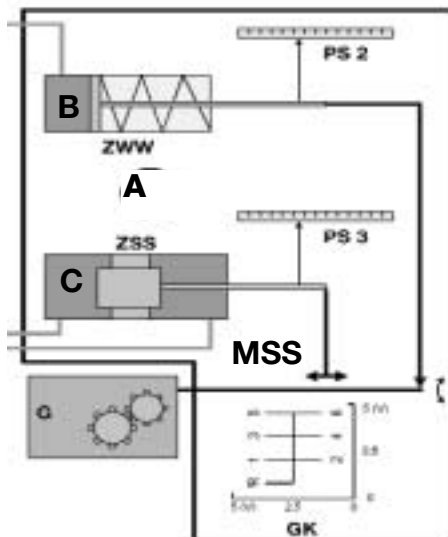

- A Gearbox Actuator
- B Selection Angle Cylinder with Position Sensor PS2
- C Shift Travel Cylinder with Position Sensor PS 3
- G Manual Gearbox
- GK Position Sensor Voltage Matrix
- MSS Main Selector Shaft

45-01-16

Position Sensor



The Position Sensors (PS2,PS3) for Selection Angle and Shift travel are potentiometers and installed in a single housing.

45-01-16

Position Sensor view from rear of Transmission

Clutch Slave Cylinder with PLCD

The Clutch Slave Cylinder is an innovative and new feature of the SMG II. The component consists of a slave cylinder with an integrated sensor housing. The sensor termed PLCD (Permanent Linear Contactless Displacement) measures clutch release travel.

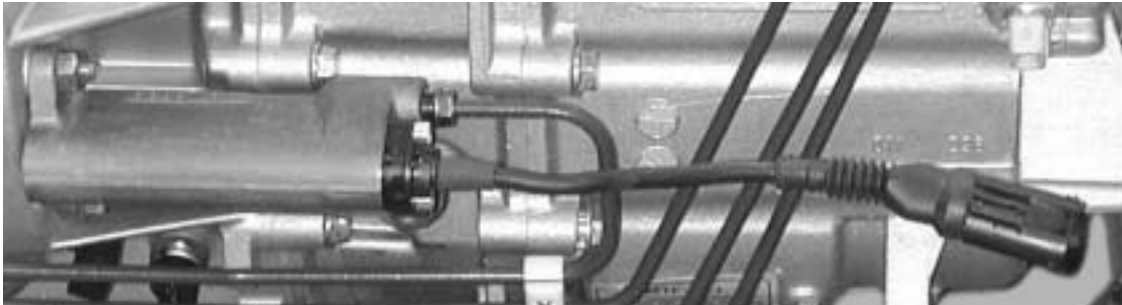

SMG II Slave Cylinder with PLCD

43-01-22

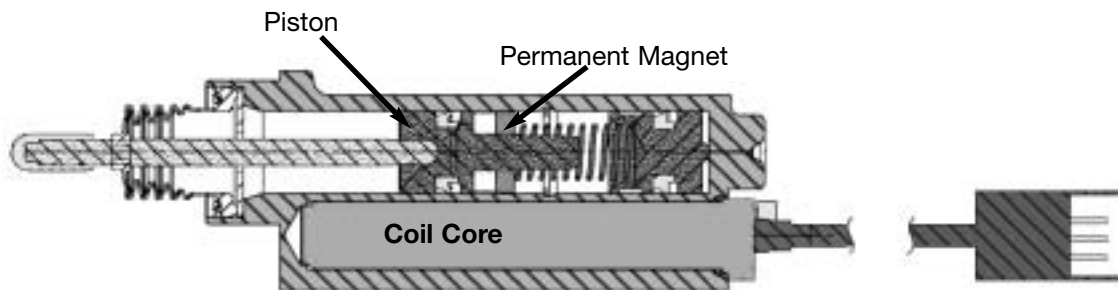

43-01-22

Shift Lever

Hall effect sensors are mounted in the Shift Lever Module to detect position and movement of the shift lever. A total of 8 hall sensors are used in the shift lever module with 4 sensors dedicated to +/- gear change requests and mode changes requests (A to S mode).

Two sensors are used for detection of the reverse gear position and two for detection of the neutral shift lever position.

The following shift lever positions are possible:

- Reverse (R)
- Idle-Speed (0) (Neutral)
- Forward/Sequential Mode (S-Mode)
- Change positions
 - + for Upshifts
 - for Downshifts
- Mode Change (A/S Modes)

A spring loaded mechanism holds the shift lever in the forward, idle-speed and reverse positions.

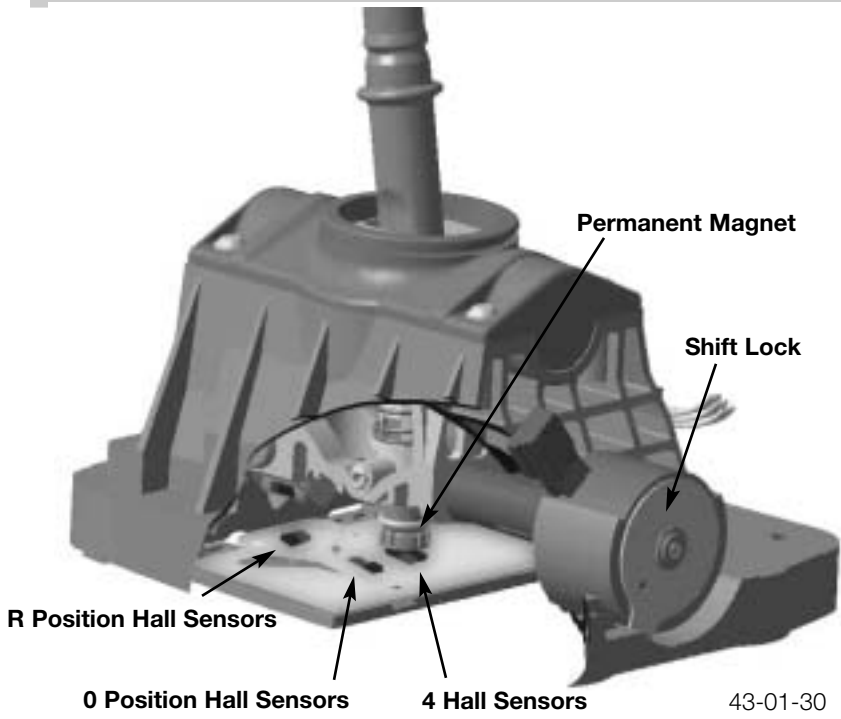

- Permanent Magnet
Located at bottom of shift lever
- Shift Lock
Located towards front of shift module
- 4 Hall Sensors
Used for detection of +/- gear change requests and mode change requests
- 0 Position Hall Sensors
Used to detect idle-speed position (0)
- R Position Hall Sensors
Used to detect Reverse position (R)

R Position Hall Sensors

0 Position Hall Sensors

4 Hall Sensors

43-01-30

SMG II Shift Lever Module

Upshifts and downshifts are made by moving the shift lever in the up or down direction from the spring latched forward position. Moving the shift lever back shifts the transmission up one gear, moving the lever forward shifts the transmission down one gear. The shift lever must be returned to the middle position to engage another upshift or downshift.

Moving the shift lever to the right while in the forward position changes the shift modes from A-Mode to S-Mode and back again.

Programming in the SMG II control unit will prevent impermissible downshift requests.

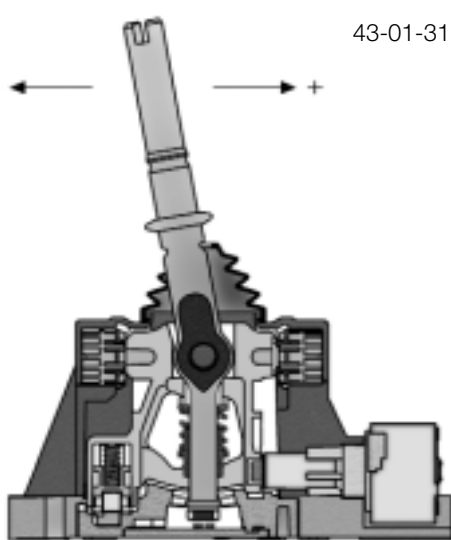

Side Cross Sectional View

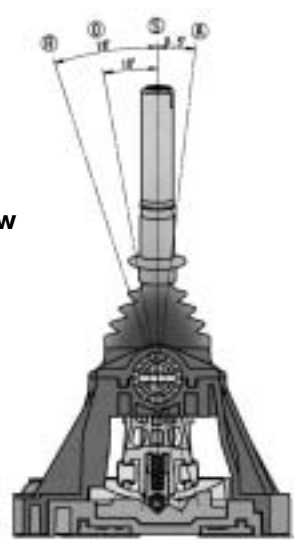

Rear Cross Sectional View

43-01-32

Shift Lock

The shift lock prevents unintended gear changes.

For safety reasons the brake pedal must be depressed before the shift lock is disengaged, allowing gear selection. Once a gear (either R or 1) has been engaged, shifting between R and 1 can be accomplished without stepping on the brake pedal for a time period of 2 seconds. When 2 seconds has elapsed, the shift lock will engage preventing shifting between R and 1 unless the brake pedal is depressed again.

The shift lock is energized in the unlocked position and rests in the lock position.

Steering Wheel Paddle Switches

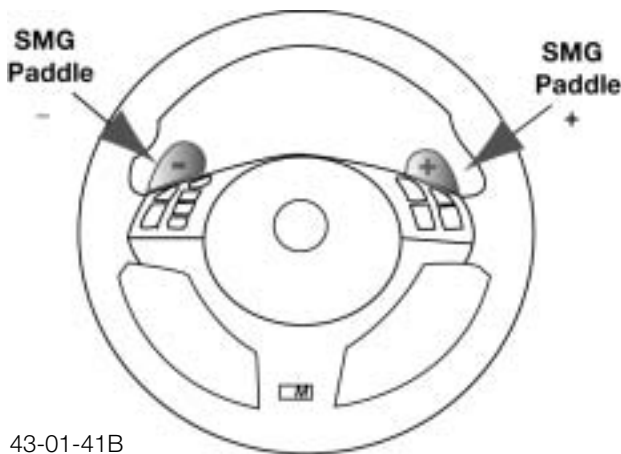

SMG Steering Mounted Paddle Switches

- + Request upshift
- Request downshift

43-01-41B

The Steering Wheel Paddles Switches are hardwired to the SMG II control unit and are used to request upshift and downshifts. Pulling on the right side paddle will request the SMG II control to make a shift to a higher gear. Pulling the left side paddle request a shift to a lower gear.

Both paddles provide a momentary switched ground signal to the SMG II control unit.

DRIVELOGIC Control

The DRIVELOGIC Control makes it possible for the driver to adapt the gearshift characteristics of the transmission to his own individual style with each driving mode (A-Mode, S-Mode).

The DRIVELOGIC Control Button is located on the center console just to the rear of the shifter. The button provides two inputs to the SMG II control unit. Both inputs are momentary switched grounds, one for program mode up and one for program mode down.

DRIVELOGIC Control provides selection of 5 programs in the A-Mode and 6 programs in the S-Mode. The individual programs differ as follows:

- A-Mode

There are 5 automated gearshift programs from A1(Winter mode, vehicle starts off in 2nd gear) to A5 (Sport mode, a highly dynamic program).

- S-Mode

There are 6 different sequential gearshift programs from S1 (Slow, relaxed shifts with soft clutch engagement) to S6 (Very fast shifts with quick clutch engagement, only accessible with DSC turned off).



SMG II Shifter and DRIVELOGIC Control

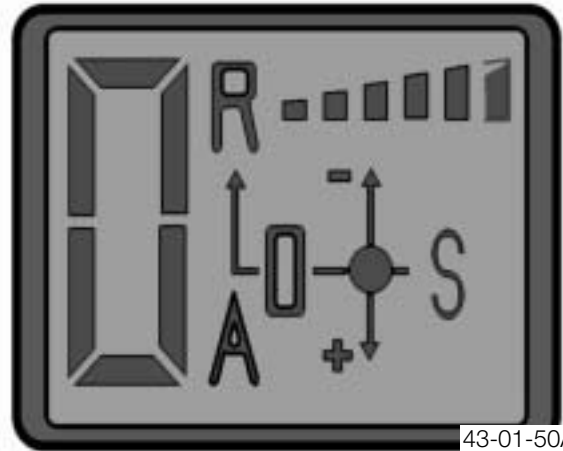

SMG II Display Vehicle in A-Mode

SMG II Electronic Display Unit

Located in the instrument cluster just below the tachometer is the SMG II Electronic Display Unit. Information on the display is sent from the SMG II control unit to the instrument cluster via the MS S54 control unit.

The shift program, the gear engaged and the mode are indicated in the display.

- 0 Indicates vehicle is in idle-speed or neutral. This portion of the display changes dependent upon gear selected. Possible displays are: 0, 1, 2, 3, 4, 5, 6 or R.
- The bar graph indicates the drive program selected. The number of the bars lighted correspond to the program number (ie. 5 bars lighted means 5th program selected).
- The A next to the gear selected indicator shows the A-Mode is active. The A will disappear when the gear shift lever is moved to the right and S-Mode becomes active.
- The S next to the gate indicates the S-Mode is available. When S-Mode is active, and A will be displayed here.
- Gate Diagram in the display shows movement paths of the shift lever for upshift and downshift requests and reverse.

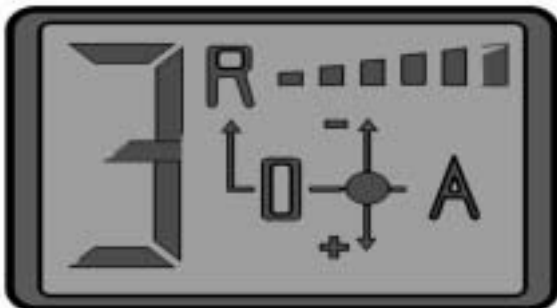

SMG II display indicating:

- 3rd Gear
- S-Mode
- 5th Program

43-01-50B

Shift Lights

In S-Mode optimum shift points are indicated by LED's integrated into the tachometer. As the tachometer approaches redline a sequence of LED's illuminate on the face of the gauge. As the tach reaches the optimal shift point the final LED illuminates; this red LED indicates the optimal shift point.



Shift Lights

43-01-51

DSC Control Unit

Data concerning transverse acceleration and wheel speed (all 4 wheel speed sensors) is relayed to the SMG II control unit via the MS S54 control unit.

Unless specifically switched off Dynamic Stability Control remains in operation during all modes in A-Mode and in all S-Modes except program S6.

Regardless of the last setting, DSC is automatically activated whenever the car is started.

SAC Clutch

The SMG II operates with the SAC clutch used in the S54B32 manual gearbox.

The pressure force of the pressure plate over the driving disc onto the flywheel remains the same over the clutch's entire operating time.

The release force is likewise the same over the operating time. The shift quality in the SMG II thus remains the same.

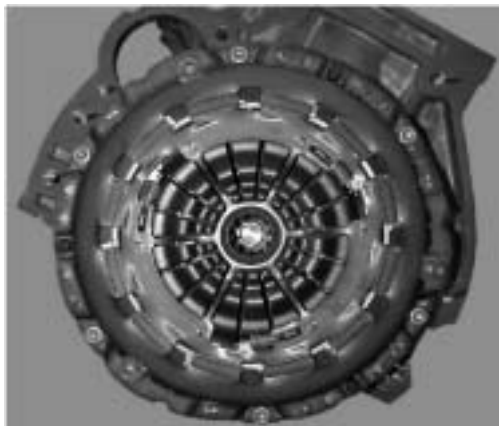

Self Adjusting Clutch (SAC)

Workshop Hint

FC 68 Indicates discrepancy between input and output speeds in relation to gear engaged. Clutch is slipping.

43-01-97

Principle of Operation

Engine Starting

Unlocking the car or opening the drivers door wakes up the GM which sends a wake up call to the SMG II control unit. Awoken the SMG II looks at hydraulic pressure stored in the accumulator. Pressure greater than 45 causes the SMG II to wait for starting initiation. Hydraulic pressure under 45 bar, causes the SMG II to energize the hydraulic pump relay, powering up the pump to build system pressure in anticipation of a start sequence.

Engine starting is only possible when the shift lever is in the 0 (idle-speed or neutral) position and the brake pedal is depressed. If a gear is selected before the key is turned to the start position or if the vehicle has been parked in gear, the shift lever must first be moved to the 0 position and the brake depressed.

Responsibility for starter operation remains with the EWS module. As the key is turned to the KL50 position, the EWS module waits for confirmation from the SMG II control unit that the shift lever position is 0 and that the brake pedal is depressed. The SMG II control unit is notified of KL50 and brake pedal position via the SMG CAN Bus by the MS S54. Receipt of notification of KL50 causes the SMG II control module to check shift lever and brake pedal position. Seeing shift lever position 0 and the brake pedal depressed, the SMG II momentarily supplies a switched ground signal to the EWS module to serve as a release to allow starter engagement. Upon receiving these confirmations the EWS module activates the starter.

The clutch is open (not engaged) during start-up operation.

Engaging A Gear

Once the engine is running the driver is able to engage the gear selection of choice through the shift lever.

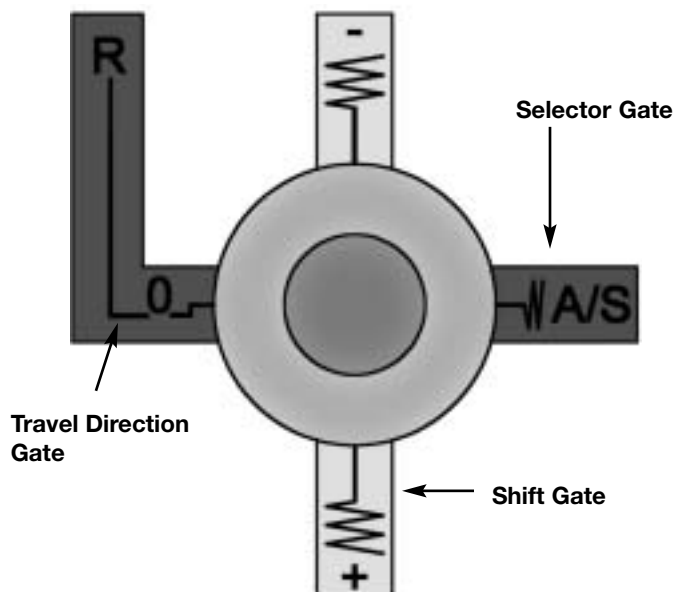

The shift lever may be moved in the following directions:

Travel Direction Gate for selecting direction of travel (Forward, Neutral (0) and Reverse).

Selector Gate for changing operating modes (A-S and S-A).

Shift Gate for selection of Specific forward gear (1-6).

43-01-70

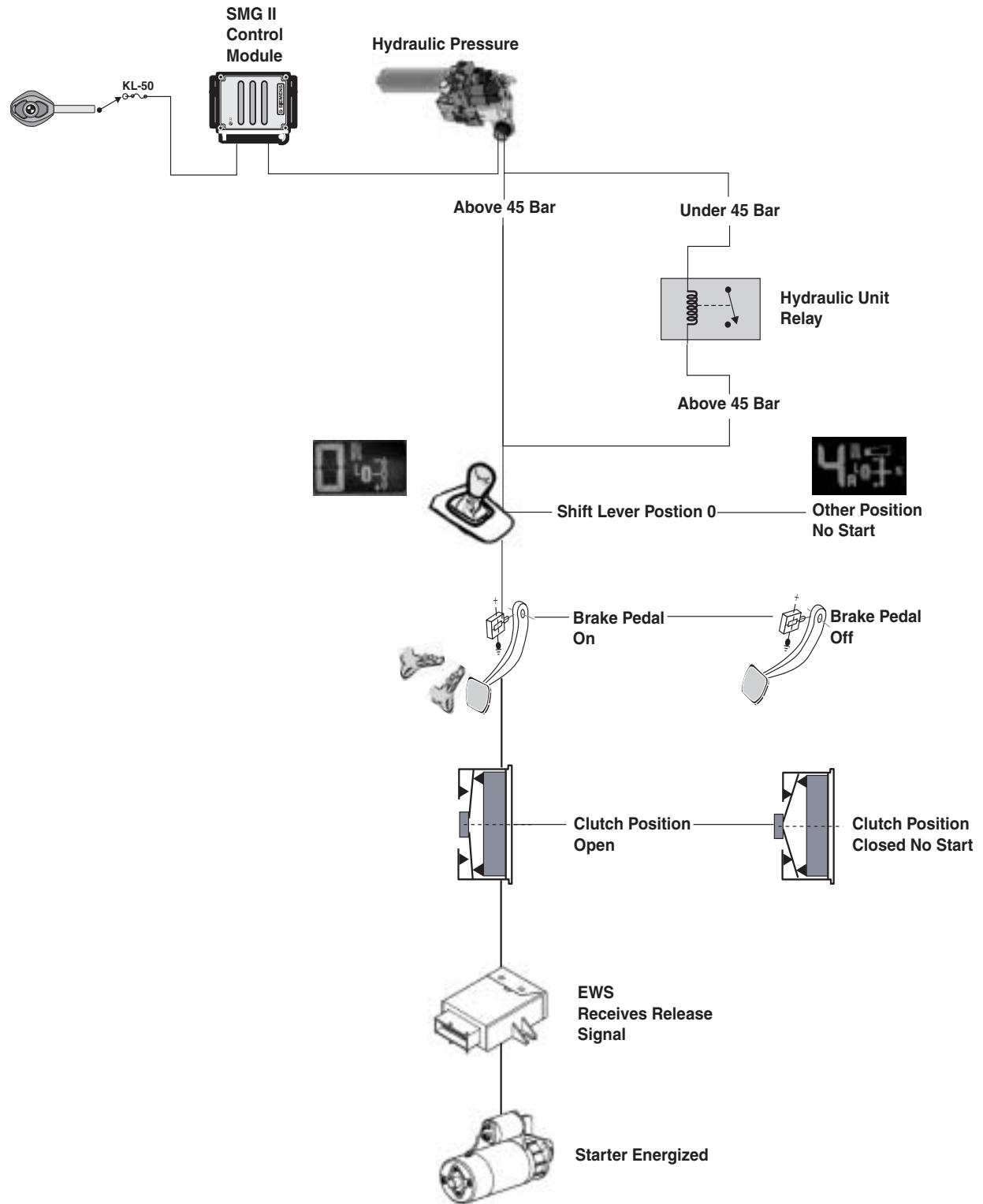

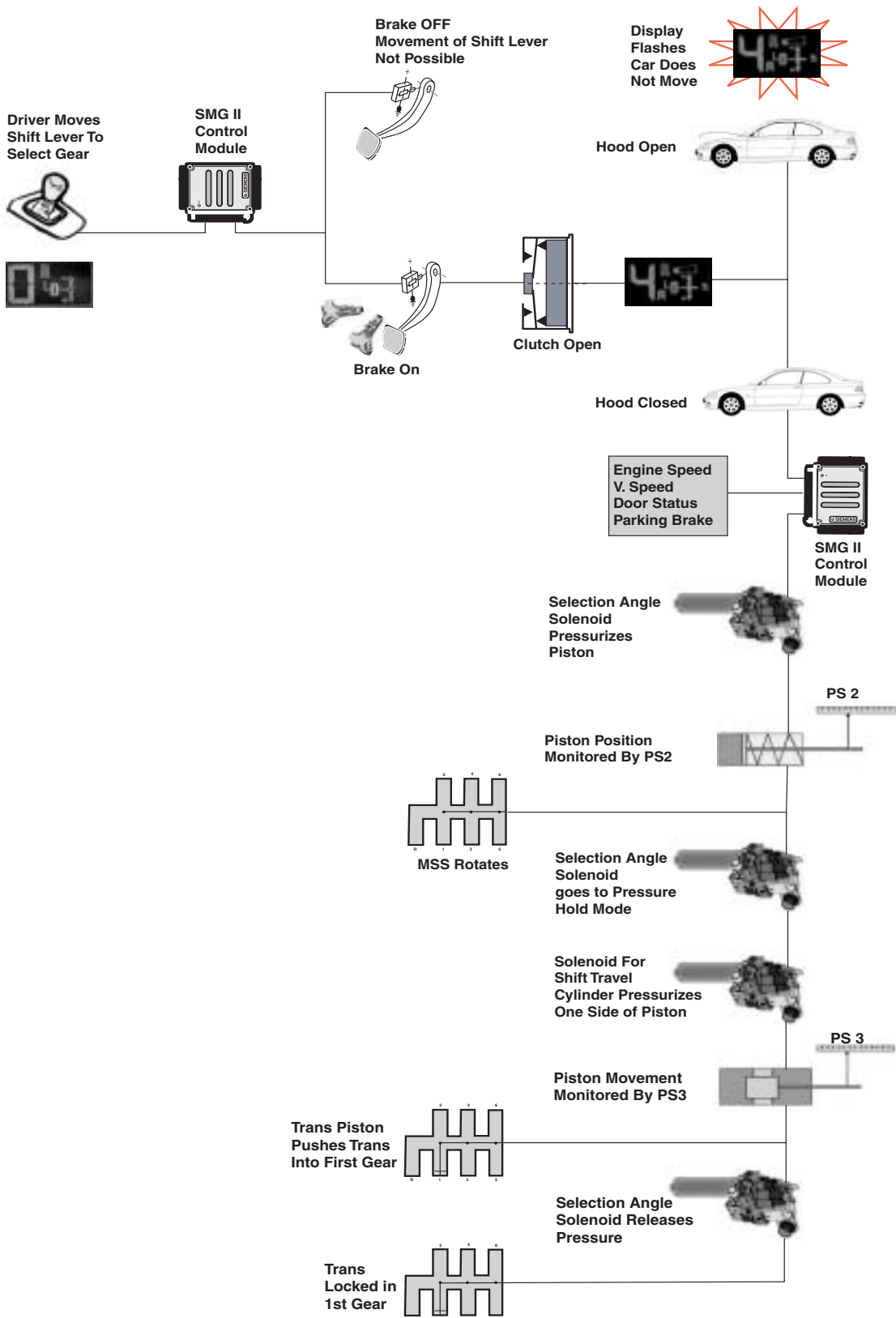

Input from the hall effect switches in the gear shift lever is sent to the SMG II control unit. Status of the hood and brake pedal input is checked and the SMG II control unit looks at vehicle speed, engine speed, hand brake status and door position. With first gear requested and status of the inputs correct, the selection angle piston is pressurized until the main selector shaft reaches the shift gate between 1st and 2nd gears as indicated by the position sensor in the gearbox actuator assembly. The selection angle piston is then placed in pressure holding position and the shift travel cylinder is pressurized on one side by operation of the two shift valves in the hydraulic unit causing it to push the main selector shaft in the appropriate direction, engaging 1st gear.

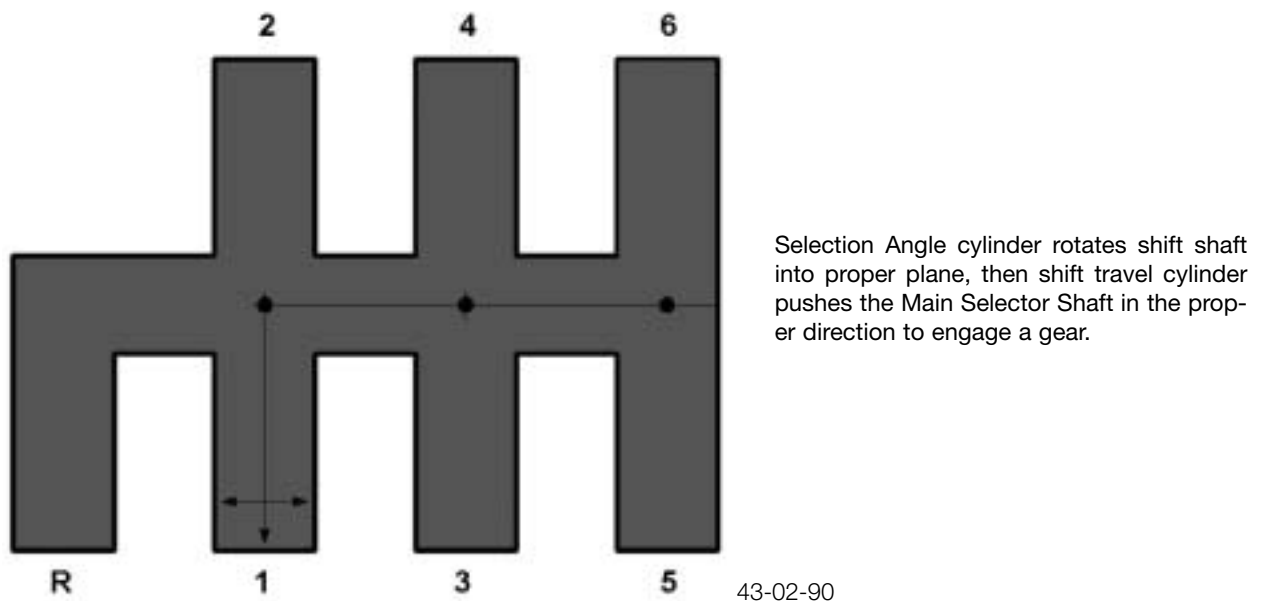

First Gear Engaged

Engagement of the gear via the shift travel cylinder takes place in three phases with differing pressures.

- Phase 1 is the distance which must be covered from the central position of the shift gate to the synchronization point with the gear to be engaged occurs.
- Phase 2 is the engagement of the synchronizers.
- Phase 3 is the distance that the shifting sleeve must travel after engaging the synchro-mesh mechanism before passing over the teeth of the gear wheel.

In three phases, varying pressures applied to the piston to ensure that the gear shift takes place with maximum comfort under minimal material load conditions and minimal wear.

Pressure is now relieved on the selection angle piston and a spring in the selection angle cylinder forces the piston back until the main selector shift contacts the flank of the 1st gear gate. The transmission is now firmly in 1st gear.

The number 1 is lighted in the shift display as communicated by the SMG II control unit to the DME and further passed on to the IKE via the CAN Bus. The SMG II control unit then looks at hood status and if closed allows clutch engagement. Hydraulic pressure to the clutch slave cylinder is controlled by a PWM signal to the Hydraulic Unit and based on engine speed, engine load, temperature, door contacts and inputs from the DSC.

Upshifts and Downshifts

The mechanical procedure for shifting whether up or down remains the same. The following sequence occurs during an upshift from 1st to 2nd.

- The selector angle cylinder is pressurized moving the MSS to an “unlocked” position in 1st gear. When the “unlocked” position is recognized by the Position Sensor, the selector angle cylinder is placed in the pressure holding mode.
- Pressure is applied to one side of the shift travel cylinder, causing the MSS shaft to move across the neutral gate into 2nd gear.
- 2nd Gear is engaged and the pressure on the selector angle cylinder is released, “locking” the transmission in 2nd gear.

All the upshifts and downshifts are made dependent on programming and mode selection.

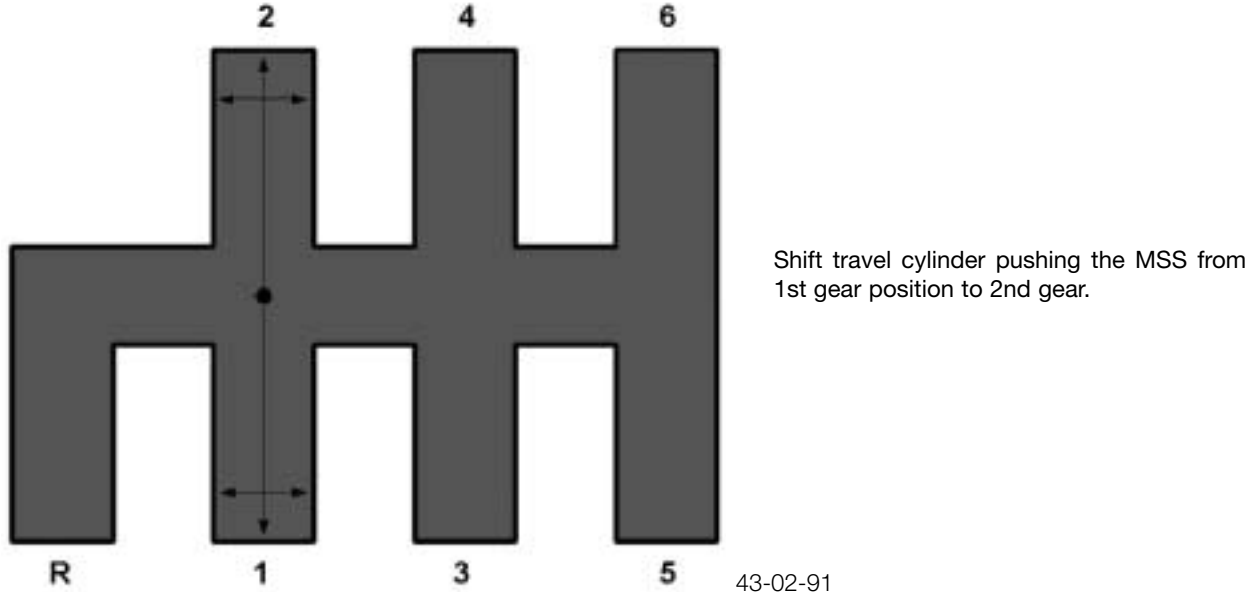

Transmission is shifted from 1st to 2nd gear.

The forces required for shifting are strongly dependent on gearbox-fluid temperature. The fluid pressures acting on the pistons of the two shift cylinders are adapted according to fluid temperature.

Shifting Operation

Depending on the driving situation, distinctions are made between trailing-throttle upshifts, trailing-throttle downshifts, acceleration upshifts and acceleration downshifts. The complete shifting operation takes place in 3 phases.

- **Clutch disengagement**

The DME calculates engine torque in anticipation of a gear change. When a gear change is initiated, the speed at which the clutch is disengaged is based on this calculation. Engine torque (and rpm) is reduced as the clutch is being disengaged until a predetermined set point is reached where engine torque and clutch torque are approximately equal. The selector angle cylinder has begun to pressurize and the MSS reaches the neutral or “unlocked” position while still in gear. At this point the shift begins.

- **Shift to Target Gear**

The quickness of the gearshift is defined by the SMG II control unit and influenced by the DME. Engine RPM drops off rapidly during the shift but engine torque remains relatively flat. When clutch disengagement confirmation is received by the SMG II the shift travel cylinder is pressurized on one side forcing the MSS into the neutral position in the gate (i.e. between first and second gears). Additional pressure is added causing the synchronization of the next gear and finally the MSS is driven to fully engage the gear. The pressure is then relieved from the selector angle cylinder.

- **Clutch Engagement**

As soon as the target gear has been engaged fully the clutch begins to move at a speed determined beforehand by the DME. Engine RPM and torque begin to increase. The objective of the programming is to configure the meeting point of the engine and clutch torques as smoothly as possible by the engine management system.

Driving and Shift Programs

There are two drive programs for the SMG II: **A-Mode** for automated shifting and **S-Mode** for sequential shifting. Furthermore, the driver can use a DRIVELOGIC control in A/S mode to match the shift point characteristics as closely as possible to his driving style. For this purpose, 5 programs in A mode and 6 programs in S mode can be selected respectively. The individual programs differ as follows:

- **A-Mode**, automated

There are five different automated shift programs, from A1 (pulling away in 2nd gear) to A5 (sporty).

- **S-Mode**, sequential

There are six different sequential shift programs, from S1 (relaxed dynamic) to S5 (sporty) and, as a special function, S6 (super sporty).

In S mode, the 6th program can only be activated if the DSC function has been deactivated beforehand. The 6th program becomes active when the DRIVELOGIC control is operated.

Only in this program is it possible also to activate the acceleration boost. This ensures that the BMW E46 M3 receives the optimum propulsion. Naturally this places the highest load on the vehicle components affected and so increases wear.

The driver is shown which mode and which program has been selected by the SMG II display unit in the instrument cluster.

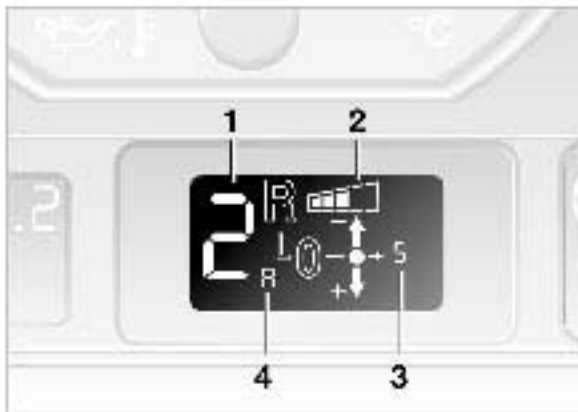

1. Gear Selected
2. Drive Program Selected
3. Shift Mode, A/S Mode
4. A Mode is active

43-02-93

SMG II Display in Instrument Cluster

A Mode

- **Shift programs A1 to A5**

If the driver has selected A mode using the selector lever, gearchanges are automated according to the road speed, the position of the accelerator pedal and the DRIVELOGIC control in the center console.

A mode is cancelled if the driver pulls one of the two shift switches on the steering wheel, moves the selector lever towards -/+ or activates S mode by briefly pressing the selector lever to the right.

Five shift programs (A1-A5) are available to the driver in A mode. The software for the five automated mode shift programs is stored in the SMG II control unit. The car drives in the winter driving program (A1) up to the sporty highly-dynamic program (A5).

Functions are also included to detect ambient conditions automatically and to influence the optimum gearselection.

- Upshift suppression
- Downshift suppression
- Cornering
- Uphill-driving detection
- Downhill-driving detection
- Braking retardation

A1 program (winter driving program)

On road surfaces with a low coefficient of friction, e.g. snow or black ice, it is possible to start off in 2nd gear by selecting the A1 program.

Upshift/downshift suppression

When driving, the driver may be forced to adapt the car's speed repeatedly to the flow of traffic by heavy braking and acceleration according to the traffic situation.

The rapid release of the accelerator pedal and rapid acceleration are detected by the SMG II control unit. If this exchange sequence takes place in short time intervals, the gearbox suppresses upshifting when the accelerator pedal is released and downshifting when it is depressed.

Upshifts to the economical gear only take place once the accelerator pedal has remained in the same position for a brief period.

Cornering

If the accelerator pedal is rapidly released before the car corners, an upshift does not take place, nor does an upshift take place while the car is cornering.

If an upshift were to occur while the car was cornering, the braking effect of the engine would be reduced or cancelled entirely, which in turn could reduce the car's rate of deceleration and it would be necessary to change back down to improve acceleration to accelerate out of the corner.

Cornering is detected by the SMG II control unit by means of the DSC lateral acceleration and steering angle detection.

Uphill-driving detection

Compared with driving on a level surface, tractive resistance during uphill driving increases by the component of the downgrade force. This requires increased engine power to maintain a constant speed. Increased engine power is achieved by having the throttle open at a slightly later stage. A downshift to a lower gear occurs to increase the engine speed depending on the road speed.

Assuming that the speed is to be kept constant, the throttle valve angle must now be reduced, which in turn would result in an upshift. The result would be damaging back-and-forth shifting if the gradient were to be negotiated at a constant speed.

Characteristic maps are stored in the control unit's software to suppress shifting of this type. The characteristic maps suppress back-and-forth shifting and provide the engine with the optimum traction force.

Downhill-driving detection

The rule of thumb that the same gear should be used for descending a gradient as for ascending the same gradient still applies.

This ensures that the engine's braking effect is exploited. The driver does not have to depress the brake pedal as frequently. This represents a clear improvement in comfort and takes the strain off the service brake.

This is made possible by the implementation of a downhill-driving detection function in the form of software. The control unit identifies that the vehicle speed is increasing in spite of overrun conditions and infers a downhill-driving scenario.

The logic circuit in the control unit begins by preventing a shift to the gear one higher.

Nevertheless, if the vehicle speed increases in such a way that braking is required, a downshift takes place automatically to the gear one lower. This procedure can be repeated as many times until 1st gear is engaged.

The required data for downhill-driving detection are engine load, vehicle speed, longitudinal acceleration and service-brake condition.

Braking retardation

Because of the nature of an automatic transmission, releasing the accelerator pedal at medium or high driving speed results in an upshift. If the vehicle is then accelerated again, the accelerating performance is insufficient or a downshift must take place with more marked acceleration. In order to prevent this behavior, the braking-retardation signal is directed to the control unit.

Depending on the extent of braking retardation, a downshift to a lower gear is executed during the braking procedure. This ensures that the appropriate gear is engaged when the driver stops braking and starts accelerating.

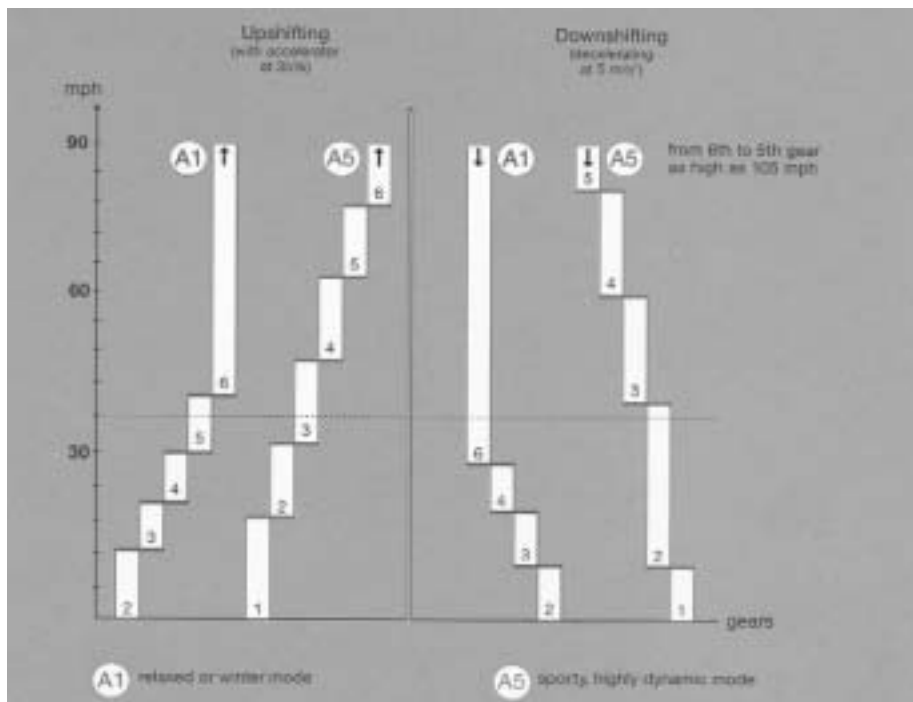

SMG II Automated Shifting

43-02-96

S mode, sequential

Shift programs S1 to S5

The selector lever or the shift paddles on the motorsport multifunction steering wheel can be used to change gear in sequential mode (S mode). In principle all shift operations are executed.

There is no forced upshift when the maximum engine speed is reached. The driver is reminded visually by LEDs (shift lights) in the instrument cluster to make the necessary gearchange at full load before the engine's limit speed is reached.

It is possible to shift through several gears by multiple-touch operation. Gearshifting in the gearbox does not always have to take place sequentially. The driver can skip a gear by shifting very quickly.

If the driver changes down twice in rapid succession before the gearchange for the first shift command has time to complete, the gearchange is prevented in the gearbox and the gear selected by the second shift command is selected.

Downshifts which would cause the maximum engine speed to be exceeded are refused. If the driver forgets to change down as the car's speed decreases, a downshift is executed automatically when the road speed falls below a gear-dependent threshold stored in the control unit. This ensures perfect vehicle acceleration when the accelerator pedal is depressed.

Hill-climbing assistance

The SMG II is equipped with special software in order to facilitate driving off on an incline. On an ascending road, the vehicle would roll back when the brake pedal is released.

The driver can activate this function by pulling the shift switch (-) on the multifunction steering wheel for a period of 0.5 seconds while the vehicle is stationary and with the brake pedal pressed. The engine speed is increased in line with the gradient. When the brake is released, the clutch is moved to the biting point and so the car is held momentarily at the point of rolling back on an uphill gradient.

When the accelerator pedal is depressed, the clutch opens and the vehicle moves off in 1st gear. If the accelerator pedal is not pressed, the clutch opens again (after approx. 2 seconds) and the vehicle may roll back.

Note:

This mode is not for extended use. Vehicle will be held only for 2 seconds. Holding vehicle on upgrade by holding slight pressure on accelerator pedal applies clutch. Doing so will cause excessive wear on clutch and lead to failure.

Acceleration boost (S6)

To activate the acceleration boost, it is necessary for the DSC to be deactivated and the S6 shift program to be active. Only with this setting is it possible to perform a "racing start".

The shift lever must now be pushed forwards and the accelerator pedal depressed. The acceleration boost is performed once the shift lever has been released. Subsequent gear shifts must be initiated manually.

There are two modes included in the acceleration boost S6 position. The "racing start" and the "burnout" modes. The difference in the activation of these two modes is the rate at which the accelerator pedal is depressed.

Depressing the accelerator slowly to the floor activates the "racing start" mode. In this mode the clutch is pulsated at a high rate (up to 8 times a second) and the vehicle accelerates at the fastest speed possible without spinning the tires. The wheel speeds on the front and rear axles are compared with each other and the car pulls away according to the clutch biting point in order to achieve optimum propulsion.

Depressing the accelerator pedal very quickly to the floor activates "burnout" mode. This mode releases the clutch totally and completely when the shift lever is released. In this mode the rear tires are very likely to lose traction and the rear of the car to become unstable. Wheel speeds are ignored and the driver is in total control of wheel spin.

Note:

Both acceleration boost modes are hard on the clutch and driveline and continued use of these modes (particularly the "burnout" mode) may lead to clutch or driveline failure.

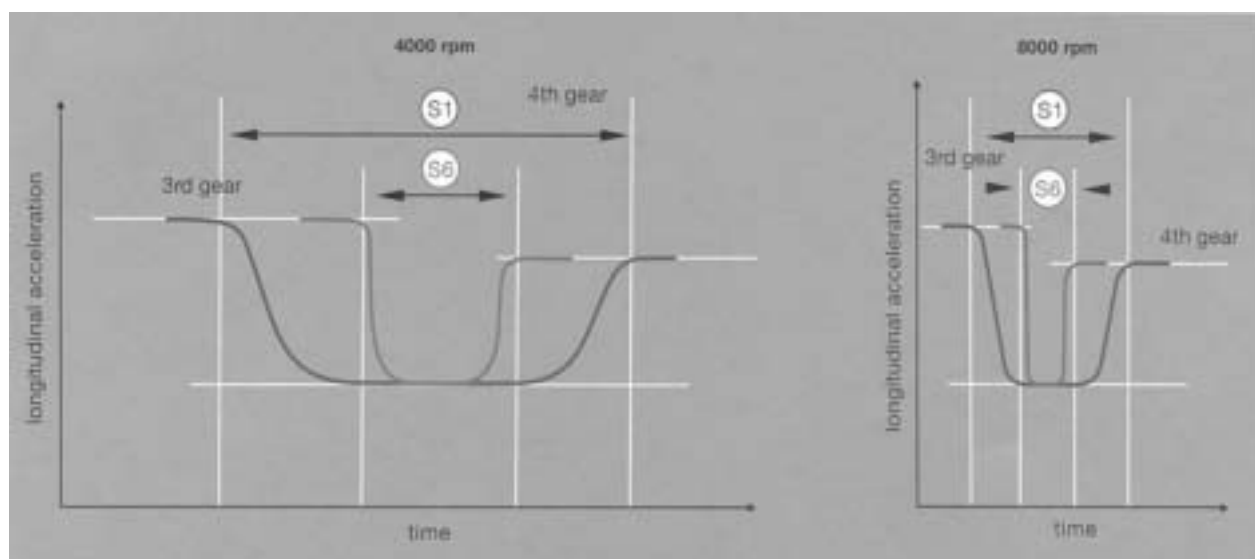

Other Shift Functions

Slip Alert System

Under Slippery or inclement situations the SMG II can alter the clutch engagement and engine RPM to ensure the rear wheels never break traction. Functional in either sequential or automated mode, Slip Alert checks for tire slippage every 10 ms and also operates even with the DSC turned off.

Double Declutching

To prevent a fast downshift from upsetting the M3's composure in any way, the SMG II will automatically double clutch and raise engine speed on downshifts to guarantee that engine RPM and road speed are perfectly matched before the lower gear engages. The result is quicker, smoother downshifts with less wear on the clutch and less chance of upsetting the car's chassis.

Changing gears without altering the position of the accelerator pedal

The driver is not required to take his foot off the accelerator pedal during the shifting operation. This applies to both automatic and manual mode. The engine management system determines when a gearchange is necessary. All engine interventions, such as ignition timing intervention, cylinder fade-out and throttle adjustment are carried out automatically by the MS S54.

If an upshift to the gear one higher takes place, the engine speed must be lower after the shift operation. The speed is set by the ignition or the throttle.

If a downshift to the gear one lower takes place, the engine speed must be higher after completion of the shift operation. The speed is increased by means of a corresponding opening of the throttle.

Safety Functions

It is not necessary to disengage the gear to stop the car, regardless of whether the car is being driven in A mode or S mode.

If the SMG II control unit detects that the selector lever is in the idle-speed position and the engine speed is lower than the threshold set for a particular temperature, the clutch is automatically disengaged to prevent the engine from stalling.

If the driver takes no action, such as opening the driver's door or depressing the brake pedal, within a certain time of the car reaching a standstill with the engine running and a gear engaged, the gearbox is shifted to neutral. The last active gear is engaged once an appropriate action has been made.

If the driver's door is opened while the vehicle is at a standstill with the engine running and a driving position selected, the gear is disengaged after a preset time threshold if no action is taken within this time at the accelerator or brake pedal.

In this situation, the driver will be warned after a preset time by the gear indicator flashing and an acoustic signal of the need to disengage the gear. The warning remains, even after the gear has been disengaged. Regardless of the safety function, the shift display always flashes while the engine is running and the driver's door is open.

The safety function is terminated as soon as the selector lever is moved to the 0 position.

Hood Open

If the hood is opened while the car is at a standstill with the engine running and a gear engaged, or if the car's condition is unclear due to a system fault, the gear is disengaged. It is not possible to pull away and the gear indicator flashes when the hood is open, regardless of the safety function.

Shift Lock

A shift lock prevents an unintended gearchange.

It is possible to only engage a gear with the brake applied, except that when shifting from Reverse to 1st or 1st to Reverse, shifting may be accomplished if the car is not moving for a time period of approximately 2 seconds.

The two seconds enable a rapid shift from position "R" to a forwards gear via position "0" without having to depress the footbrake.

The shift lock is activated by a magnet, which locks the selector lever at zero current in the "0" position.

Engine shutoff

If the key is turned to position 1 or 0 in the ignition while the selector lever is in the forwards or reverse position, a gear automatically remains engaged.

If the key is turned to position 1 or 0 in the ignition while the selector lever is in idle-speed position 0, a gong sounds and the gear indicator flashes in the SMG display as a reminder that the car has not been secured against rolling away.

The warning is silenced after approximately 10 seconds. If the selector lever is moved to the forwards or reverse position during this time, a gear is engaged automatically.

Emergency Acceleration

Emergency Acceleration is possible regardless of the shift mode (A-Mode or S-Mode) or the DRIVELOGIC position engaged.

Depressing the accelerator pedal quickly to the floor without the brake pedal depressed will engage emergency acceleration. The engine RPM will come up very quickly and the clutch will be pulsated to ensure maximum acceleration. Wheel spin will be limited even if DSC is switched off.

When this mode is activated subsequent shifts must be made manually.

SMG II Diagnosis

The SMG II control unit is fully diagnosable and can be checked using a DISplus Tester or GT1.

The first step involves the fault memory being read out. Malfunctions are communicated as part of the SMG II control unit's self-diagnosis. The second step involves appropriate operator prompting to facilitate diagnosis with simple measuring equipment using test modules. Repairs can be made once the fault in question has been found.

The diagnosis including self-diagnosis can only be carried out when the ignition (terminal 15) is switched on and there is a supply voltage of at least 10 volts. Erroneous fault entries may be recorded if the supply voltage drops below the threshold of approx. 10 volts.

Service functions

A test program (service functions) must be carried out upon completion of various types of work on the SMG system – see the following table. The test programs serve to implement test, initialize and adjustment functions.

The values determined are permanently stored in the non-volatile memory only after the test program has been successfully completed.

Notes:

Function	Implementation	Conditions	Timeout
Initialize "0" Position in Accelerator Pedal	When replacing the control unit and/or the accelerator pedal module.	The accelerator pedal must be in position "0"	15 secs.
Initialize Idle Speed Position		The engine must be warm, the accelerator pedal must not be pressed and all loads must be switched off.	15 secs.
Initialize Clutch Engagement Point	When replacing the control unit, after work on hydraulic systems (valves, cables and actuator) if the system was opened and when replacing the clutch and hydraulic unit.	The gearbox must be in the position "0", the engine must be warm, the accelerator pedal must not be pressed and the gearbox input speed must be at zero at the start of the test routine.	30 secs.
Check hydraulic lines	When replacing the control unit, after work on hydraulic systems (valves, cables and actuator) if the system was opened and when replacing the clutch and hydraulic unit.	The engine must be off and the clutch must be disengaged.	
Bleeding	When replacing the control unit, after work on hydraulic systems (valves, cables and actuator) if the system was opened and when replacing the clutch and hydraulic unit.	The engine must be off and the clutch must be disengaged.	
Initialize Shift Module	When replacing the actuator, shift lever and components	The engine must be off and the clutch must be disengaged.	
Initialize Selector Angle Cylinder	When replacing the control unit and when replacing the hydraulic unit.	The engine must be off and the clutch must be disengaged.	
Gearbox adaptation	When replacing the control unit, gearbox, hydraulic unit and the gear recognition.	The engine must be off, the clutch must be disengaged and no brakes must be pressed.	

Review Questions

1. Which control unit is responsible for managing the control of the SMG II and which module make the shift decisions?

2. What is the purpose of the SMG CAN Bus? _____

3. Why is the data from the transverse acceleration sensor only evaluated during the A-Mode of SMG II operation? _____

4. Does the cruise control become deactivated during a gear shift in the A-Mode?

How does this compare to cruise operation in the S-Mode? _____

5. Under what conditions will the hydraulic pump become energized when the engine is not running? _____

6. A customer complains that he can not access DRIVELOGIC Mode 6. What could the cause? _____

7. During engine start-up operation, the starter does not engage, what are the possible causes of this fault? _____

8. Why does the Selector angle cylinder have one electric solenoid at the Hydraulic Unit, and the Shift travel cylinder have two solenoids? _____

9. How is the Hill-Climbing Assistance feature activated? _____

10. A customer complains he hears the Hydraulic pump run sporadically, the car shifts normally, what could be the cause? _____

	Fault Type	Test Conditions	Fault Description	Ambient Conditions.	Warning Lamp	Measures	Normal Service
Gearbox Temp.	Fault sporadic, Fault currently present or Implausible value	Ignition On Battery >10 volts	Short-Circuit to ground, sensor supply or supply. Or open circuit or sensor fault	Mileage Voltage supply Ambient Temp. Gearbox Temp. Engine Temp. Hydraulic Temp.	Off	Calculate Gearbox Temp based on Engine Temp	Eliminate fault
Hydraulic Pressure Sensor	Fault sporadic, Fault currently present or Implausible value	Ignition On, Battery >10 volts and Good sensor voltage, and hydraulic pump inactive	Short-Circuit to ground, sensor supply or supply. Or open circuit or sensor fault	Mileage, Voltage supply, Ambient temp, Hydraulic temp, Sensor v supply, hydraulic pump status, current clutch solenoid	On	Hydraulic pump is switched on in fixed time intervals and with each shift for a fixed time	Eliminate fault, erase fault code
Hydraulic Pressure loss in system	Fault sporadic, Fault currently present, Invalid operation range	Ignition On, Battery >10V and Hydraulic pump fault free and hydraulic pressure sensor fault free	Pressure loss in system	Mileage Voltage supply Ambient Temp	On if hydraulic pressure <10 bar	During driving: Block gear change At standstill: Engage position "0" so that vehicle can be towed	Eliminate fault, erase fault code
Hydraulic Pump	Fault sporadic, Fault currently present, Invalid operation range	Ignition On, Battery Voltage > 10V and hydraulic pressure sensor trouble free	Short-circuit in hydraulic pump electric motor to ground, B+, or open circuit or no pressure increase with pump switched on or ON period of pump is outside tolerance	Mileage Voltage supply Ambient Temp. Hydraulic Temp. Status Hydraulic pump Current, solenoid valve, clutch	On	During driving: Continue driving for as long as possible (without changing gear). Disengage gear at lower limit pressure At Standstill: Disengage gear so that vehicle can be towed	Eliminate fault, erase fault code
Hood Contact While Driving	Fault sporadic, Fault currently present or Implausible value	Ignition On, Battery Voltage > 10V, and driving speed >40km/h and <120KM/h	Different values detected by both hood contacts during driving	Mileage Voltage supply Ambient Temp Hood Switches Vehicle Speed	Off	Car can continued to be driven until next garage visit using input from good switch	Eliminate fault
Hood contact at standstill	Fault sporadic, Fault currently present or Implausible value	Ignition On, Battery Voltage > 10V,	Different values detected by both hood contacts while vehicle is at standstill	Mileage Voltage supply Ambient Temp. Bonnet Contact Vehicle speed	Off Gear Indicator light will flash	Gear will not engage	Eliminate fault

Fault Type	Test Conditions	Fault Description	Ambient Conditions.	Warning Lamp	Measures	Normal Service
Shift Lever	Fault sporadic, Fault currently present or Implausible value Ignition On, Battery >10V	Switch Positions not Plausible or complete malfunction of shift lever	Mileage, Voltage, Ambient Temp, Driving Direction, Shift-Lever Position, Digital inputs from shift lever, target gear	On with complete failure of shift lever, otherwise off		Eliminate fault
Position sensor, selection angle	Fault sporadic, Fault currently present or Implausible value Ignition On, Battery >10V and sensor supply A trouble-free and sensor supply B trouble free	Short-circuit to ground, sensor supply or supply or open circuit or sensor faulty	Mileage Voltage supply, Ambient temperature Sensor supply A Sensor supply B Selection-angle position 1, Selection-angle Position 2	On	Failure of only one sensor Substitution by the other Sensor Failure of both sensors, Substitute program runs where manual operation is disabled. Gears R, 2, 5 and 6 can be shifted Gate position is approached under controlled conditions.	Eliminate fault
Position sensor, shift travel	Fault sporadic, Fault currently present or Implausible value Ignition On, Battery >10V and sensor supply A trouble-free and sensor supply B trouble free	Short-circuit to ground, sensor supply or supply or open circuit or sensor faulty	Mileage Voltage supply Ambient temperature Sensor supply A Sensor supply B Shift-travel position1 Shift travel position2 Engaged gear Gearbox Status	On	Failure of only one sensor, Substitution by the other sensor Failure of both sensors Substitutes driving program runs where all gears can be shifted with loss of comfort. Gears can be engaged under controlled conditions.	Eliminate fault
Longitudinal acceleration	Fault sporadic, Fault currently present or Implausible value Ignition On, Battery >10V and sensor supply A trouble-free	Short-circuit to ground, sensor supply or supply or open circuit or sensor faulty	Mileage Voltage supply Ambient temperature Sensor supply B Longitudinal Acceleration Vehicle speed Brake Signals	Off	Longitudinal acceleration = 0 g Moving off on incline possible in 2 nd gear	After Fault is eliminated
Sensor voltage supply A	Fault sporadic, Fault currently present or Implausible value Ignition On, Battery >10V	V sensor supply/A < 4.5 V. V sensor supply/A > 5.5 V Impairment of longitudinal acceleration Signal, selection angle 1 Signal, shift travel 1	Mileage Voltage supply Ambient temperature	Off	Correction of: Longitudinal acceleration Signal, selection angle 1 Signal, shift travel	After Fault is eliminated

	Fault Type	Test Conditions	Fault Description	Ambient Conditions.	Warning Lamp	Measures	Normal Service
Sensor voltage supply B	Fault sporadic, Fault currently present or Implausible value	Ignition On, Battery >10V	V sensor supply/B < 4.5 V. V sensor supply/B > 5.5 V Impairment of Gearbox Speed Hydraulic pressure Signal, selection angle 2 Signal, shift travel 2	Mileage Voltage supply Ambient temperature	On	Correction of: Gearbox speed Hydraulic pressure Signal, selection angle 2 Signal, shift travel 2	After Fault is eliminated
Gearbox input speed	Fault sporadic, Fault currently present or Implausible value	Ignition On, Battery >10V additional checks for plausibility Clutch closed and No faults in: Clutch position sensor Clutch solenoid valve Engine speed sensor Rear wheel speed sensor Gear detection Gearbox speed sensor and Engine Running	Overspeed or Maximum gradient fault or if with clutch closed engine speed, gearbox input speed or gear input speed calculated from rear axle speed not plausible.	Mileage Voltage supply Ambient temperature	On	From gear ratio and gearbox output speed (rear axle speed) Use Engine speed	After Fault is eliminated
Engine speed (sensor)	Fault sporadic Fault currently present Implausible value	Ignition On, Battery >10V additional checks for plausibility Additional conditions for plausibility check clutch closed and clutch position sensor trouble-free and clutch solenoid valve trouble-free and rear wheel speeds trouble-free and engine running and CAN trouble-free	Overspeed or maximum gradient fault or if with clutch closed engine speed, gearbox speed or engine speed; engine speed from CAN	Mileage Voltage supply Ambient temperature	Off	Substitute value, engine speed, via CAN-bus	After Fault is eliminated

Fault Type	Test Conditions	Fault Description	Ambient Conditions.	Warning Lamp	Measures	Normal Service
Engine speed (sensor and CAN)	Ignition On, Battery >10V and engine running and CAN trouble-free	Engine speed from sensor and engine speed from CAN incorrect	Mileage Voltage supply Ambient temperature Gearbox input speed Engine speed Engine speed from CAN Clutch status	On	Engine speed can be partially substituted with clutch closed from gearbox speed	After Fault is eliminated
PLCD sensor for clutch position	Ignition On, Battery >10V	Hardware fault or sensor faulty	Mileage Voltage supply Ambient temperature	On	Open-loop instead of closed-loop clutch control	After Fault is eliminated
CAN incorrect value	Ignition On, Battery >10V and no other fault message from CAN	DSC delivers an incorrectly identified value				
CAN-bus fault	Ignition On, Battery >10V	Telegram is no longer received (time-out) or bus fault (interruption)	Mileage Voltage supply Ambient temperature Info on CAN fault	On		After Fault is eliminated
Speed, rear left	Ignition On, Battery >10V and driving speed > 40 km/h and brake not actuated and no wheel separation detected and no fault message via CAN	Speed, rear left > 320 km/h or speed change > 20 km/h per 10 ms or comparison with the other three wheel speeds produces an implausible value	Mileage Voltage supply U(batt.) Ambient temperature Speed, rear left Speed, rear right Speed, front left Speed, front right Clutch status Shifted gear Gearbox input speed	Off	Can be substituted: By rear right wheel speed or if rear right is also incorrect by front-axle speed or with engaged gear from gearbox input speed and gear ratio. The signal is supported until it is substituted in the event of a negative speed change.	After Fault is eliminated

Fault Type	Test Conditions	Fault Description	Ambient Conditions.	Warning Lamp	Measures	Normal Service
Speed, rear right	Ignition On, Battery >10V and driving speed > 40 km/h and brake not actuated and no wheel separation detected and no fault message via CAN	Speed, rear left > 320 km/h or speed change > 20 km/h per 10 ms or comparison with the other three wheel speeds produces an implausible value	Mileage Voltage supply U(batt.) Ambient temperature Speed, rear left Speed, rear right Speed, front left Speed, front right Clutch status Shifted gear Gearbox input speed	Off	Substituted By rear right wheel speed or if rear right is also incorrect by front-axle speed or with engaged gear from gearbox input speed and gear ratio. The signal is supported until it is substituted in the event of a negative speed change.	After Fault is eliminated
Speed, front left	Ignition On, Battery >10V and driving speed > 40 km/h and brake not actuated and no wheel separation detected and no fault message via CAN	Speed, rear left > 320 km/h or speed change > 20 km/h per 10 ms or comparison with the other three wheel speeds produces an implausible value	Mileage Voltage supply Ambient temperature Speed, rear left Speed, rear right Speed, front left Speed, front right Clutch status Shifted gear Gearbox input speed	Off	Substituted By rear right wheel speed or if rear right is also incorrect by front-axle speed or with engaged gear from gearbox input speed and gear ratio. The signal is supported until it is substituted in the event of a negative speed change.	After Fault is eliminated
Speed, front right	Ignition On, Battery >10V and driving speed > 40 km/h and brake not actuated and no wheel separation detected and no fault message via CAN	Speed, rear left > 320 km/h or speed change > 20 km/h per 10 ms or comparison with the other three wheel speeds produces an implausible value	Mileage Voltage supply Ambient temperature Speed, rear left Speed, rear right Speed, front left Speed, front right Clutch status Shifted gear Gearbox input speed	Off	Substituted By rear right wheel speed or if rear right is also incorrect by front-axle speed or with engaged gear from gearbox input speed and gear ratio. The signal is supported until it is substituted in the event of a negative speed change.	After Fault is eliminated
Speed (more than one signal)	Ignition On, Battery >10V and driving speed > 40 km/h and brake not actuated and no wheel separation detected and no fault message via CAN	Two, three or four wheel speeds deliver an implausible value	Mileage Voltage supply Ambient temperature Speed, rear left Speed, rear right Speed, front left Speed, front right Clutch status Shifted gear Gearbox input speed	On	Can be substituted: With shifted gear from gearbox input speed and gear ratio	After Fault is eliminated

Fault Type	Test Conditions	Fault Description	Ambient Conditions.	Warning Lamp	Measures	Normal Service
Service-brake signals via CAN	Ignition On, Battery >10V and no fault message via CAN	Different values from both switches or at a speed > 45 km/h with accelerator pedal pressed the signals are active for longer than 1 min or with a vehicle deceleration > 0.4 g no signal active	Mileage Voltage supply Ambient temperature Brake signals Accelerator-pedal value Vehicle speed Longitudinal acceleration	Off	Ignore incorrect signal	After Fault is eliminated
Door contact via CAN	Ignition On, Battery >10V and no fault message via CAN and vehicle speed trouble-free	Door contact active for longer than 10 seconds at a speed > 45 km/h	Mileage Voltage supply U(batt.) Ambient temperature Vehicle speed Door contact	On	Driving off only possible within 10 seconds of brake or shift-lever actuation	After Fault is eliminated
Shift lock	Ignition On, Battery >10V	Short-circuit to ground or supply or open circuit or shift-lock magnet faulty	Mileage Voltage supply U(batt.) Ambient temperature Shift-lever position Shift-lock activation	On	During driving: Continue driving for as long as possible	After Fault is eliminated
Starter-motor enabling	Ignition On, Battery >10V	Short-circuit to ground or supply or open circuit or starter-relay enabling	Mileage Voltage supply Ambient temperature Starter-motor enabling	Off	Short-circuit to supply: Permanent starter-motor enabling All other fault types: Vehicle starting no longer possible	After Fault is eliminated
Hydraulic-pump relay	Ignition On, Battery >10V and hydraulic pressure sensor trouble-free	Short-circuit to ground or supply or open circuit or hydraulic-pump relay faulty	Mileage Voltage supply Ambient temperature Hydraulic temperature Hydraulic pressure Status, hydraulic pump Current, solenoid valve, clutch	On	During driving: Continue driving for as long as possible (without changing gear). Disengage gear at lower limit pressure At standstill: Disengage gear so that vehicle can be towed	After Fault is eliminated

Fault Type	Test Conditions	Fault Description	Ambient Conditions.	Warning Lamp	Measures	Normal Service
Reversing-light switch	Ignition On, Battery >10V	Short-circuit to ground or supply or open circuit	Mileage Voltage supply Ambient temperature Activation, reversing-light switch Shift-lever position Driving direction	Off	Short-circuit to supply: Reversing light always lit All other faults: Reversing light never lit	After Fault is eliminated
Solenoid valve, shift travel up	Ignition On, Battery >10V Additional conditions for plausibility check Shift-travel position sensor trouble-free and hydraulic pressure trouble-free	Short-circuit to ground or supply or open circuit or actual current = specified current or actual position = specified position or timeout during shifting of gears	Mileage, Voltage supply Ambient temperature Hydraulic pressure Actual current, shift travel up, Specified current, shift travel up Actual position, shift travel, Specified position, shift travel Actual position, selection angle Specified position, selection angle	On	Gearbox limp-home program No further gear shifts are permitted	After Fault is eliminated
Solenoid valve, shift travel down	Ignition On, Battery >10V Additional conditions for plausibility check Shift-travel position sensor trouble-free and hydraulic pressure trouble-free	Short-circuit to ground or supply or open circuit or actual current = specified current or actual position = specified position or timeout during shifting of gears	Mileage, Voltage supply Ambient temperature Hydraulic pressure Actual current, shift travel up, Specified current, shift travel up Actual position, shift travel, Specified position, shift travel Actual position, selection angle Specified position, selection angle	On	Gearbox limp-home program No further gear shifts are permitted	After Fault is eliminated

Fault Type	Test Conditions	Fault Description	Ambient Conditions.	Warning Lamp	Measures	Normal Service
Solenoid valve, selection angle Fault sporadic present Fault currently Short-circuit to ground Short-circuit to B+, Open circuit Implausible value	Ignition On, Battery >10V Additional conditions for plausibility check Shift-travel position sensor trouble-free and hydraulic pressure trouble-free	Short-circuit to ground or supply or open circuit or actual current = specified current or actual position = specified position or timeout during shifting of gears	Mileage, Voltage supply Ambient temperature Hydraulic pressure Actual current, shift travel up, Specified current, shift travel up Actual position, shift travel, Specified position, shift travel Actual position, selection angle Specified position, selection angle	On	Gearbox limp-home program No further gear shifts are permitted	After Fault is eliminated
Solenoid valve, clutch Fault sporadic present Fault currently Short-circuit to ground Short-circuit to B+, Open circuit Implausible value	Ignition On, Battery >10V Additional conditions for plausibility check position sensor trouble-free and hydraulic pressure trouble-free	Short-circuit to ground or supply or open circuit or actual current = specified current or actual position = specified position	Mileage, Voltage supply Ambient temperature Hydraulic pressure Actual current, clutch Specified current, clutch Actual position, clutch Specified position, clutch Current gear	On	During driving: No further gear changes At standstill: Engage position "0"	After Fault is eliminated
Gearbox adaptation Fault sporadic present Implausible value	Ignition On, Battery >10V and gearbox adaptation started	Adaptation could not be properly carried out	Mileage, Voltage supply Ambient temperature Fault message of adaptation, Number of adaptation/test program Adaptation status in event of fault	On	The vehicle is only ready for operation under limited conditions, default values are used	After Fault is eliminated
Steering-angle-offset current adaptation Fault sporadic present Implausible value	Ignition On, Battery >10V and steering-angle-offset current adaptation started	Adaptation could not be properly carried out	Mileage, Voltage supply Ambient temperature Fault message of adaptation Number of adaptation/test program Adaptation status in event of fault	On	The vehicle is only ready for operation under limited conditions, default values are used	After Fault is eliminated

Fault Type	Test Conditions	Fault Description	Ambient Conditions.	Warning Lamp	Measures	Normal Service
Clutch adaptation	Fault sporadic present Implausible value Ignition On, Battery >10V and clutch adaptation started	Adaptation could not be properly carried out	Mileage, Voltage supply Ambient temperature Fault message of adaptation ,Number of adaptation/test program Adaptation status in event of fault	On	The vehicle is only ready for operation under limited conditions, default values are used	After Fault is eliminated
Gear cannot be engaged	Fault sporadic present Implausible value Ignition On, Battery >10V	Gear cannot be engaged	Mileage, Voltage supply Ambient temperature Current gear, Desired gear, Shift position Selection-angle position Gearbox input speed Gearbox output speed	Off	Shifting to the relevant gear is not possible	After Fault is eliminated
Gear popping	Fault sporadic present Implausible value Ignition On, Battery >10V	Engaged gear pops out	Mileage, Voltage supply Ambient temperature Current gear, Desired gear, Shift position Selection-angle position Gearbox input speed Gearbox output speed	Off	Shifting to the relevant gear is not possible	After Fault is eliminated
Selection angle cannot be set	Fault sporadic present Implausible value Ignition On, Battery >10V	The requested selection-angle position cannot be set	Mileage, Voltage, supply Ambient temperature Current gear Desired gear Shift position Selection-angle position Gearbox input speed Gearbox output speed	On	During driving with gear engaged: Block gear change, i.e. continue driving for as long as possible At standstill: Engage position "0" so that vehicle can be towed	After Fault is eliminated