Table of Contents

Subject	Page
Central Body Electronics (ZKE IV)2
Objectives of the Module2
Purpose of the System3
System Components4
Power Distribution5
Windshield Wiping/Washing6
318ti Rear Window Wiping/Washing8
Central Locking9
Door Lock Heating.19
Power Windows/Sunroof20
Sunroof23
Interior Lighting25
General Functions27
Consumer Cut Off/Overload Protection27
Review Questions28

CENTRAL BODY ELECTRONICS (ZKE IV)

Models: E36 and Z3

**Production Date: E36 1994 MY (including 318ti) to End of Production
Z3 Coupe, Roadster (including M) 1997 MY to Present**

Manufacturer: Hella

**Pin Connectors: 6 - Black 18 pin, Black 15 pin, Yellow 26 pin,
Green 26 pin, Natural 26 pin, White 15 pin**

Objectives of the Module

After completing this module, you will be able to:

- List the functions directly controlled by the GM IV.
- Describe how the GM IV recognizes the key position from the driver's door.
- Explain the "Comfort Closing" feature.
- Understand the difference between "single" and "double" lock.
- Describe Windshield Wiper Blocking Protection.
- Explain how EWS affects the Central Locking System.

Central Body Electronics (ZKE IV)

Purpose of the System

The Central Body Electronics (ZKE IV) system manages the following functions:

GM IV (1. in Diagram)

- Interior Lighting
- Central Locking
- Door Lock Heating
- Power Windows/Sunroof
- Consumer Cut Off/Overload
- Diagnosis

Washer/Wiper Module (2. in Diagram)

- Windshield Wiping/Washing

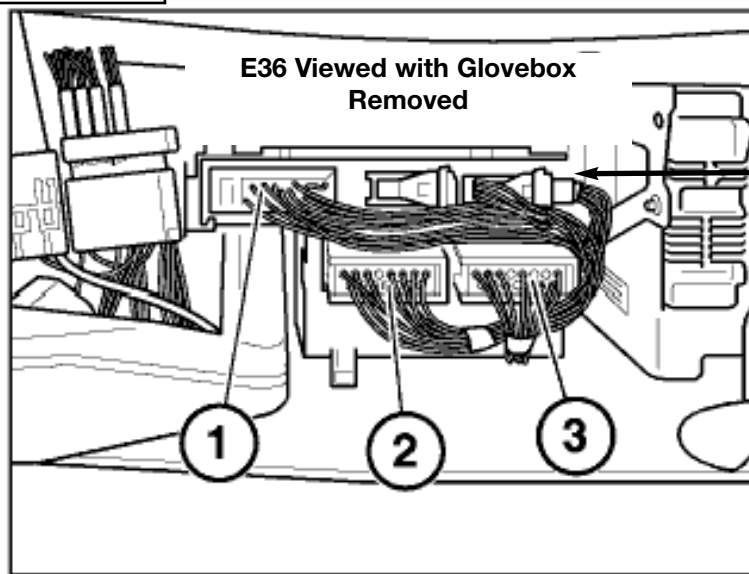

Relay Module (3. in Diagram)

- Power Windows (rear doors - on 4 door and Convertible only)

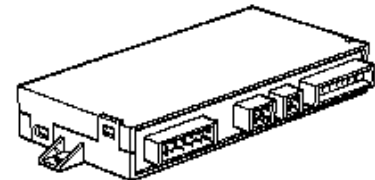

Convertible Top Module

- Power Window Interface
- Top Comfort Close
- Trunk Lockout when top is in operation

The ZKE IV system was introduced on the E36 Convertible and is also used in the Z3. Most of the functions operate the same on these vehicles with minor changes and added features to the system. ZKE IV is the fourth generation of central body control systems.

The GM IV is responsible for controlling most of the Body Electronic Functions from one central module.

System Components

General Module (GM IV): The GM is a micro-computer that is the central component (heart) of the Central Body Electronics. The GM is located behind the glove box.

The main objectives for using the GM are:

• Increase Overall Reliability
• Centralize Electronic Systems
• Decrease Assembly and Service Repairs
• Centralized Diagnosis of all ZKE Components
• Individualization of Features (Coding)

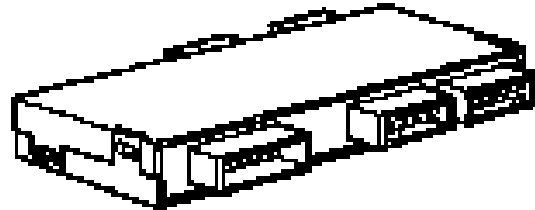

The GM requires **input** data to perform Central Body Electronics functions. The inputs are supplied by digital switched signals such as:

- **Driver's Door Lock Microswitch:** supplies voltage (KL 30) to the GM when switched. A path to ground is provided by the GM (internally). The GM monitors the input voltage.
- **Central Lock Button (E36 from 96 MY):** supplies a ground circuit to the GM when switched. The GM supplies and monitors a reference voltage (5v) that is "pulled" low when the switched ground path is provided.

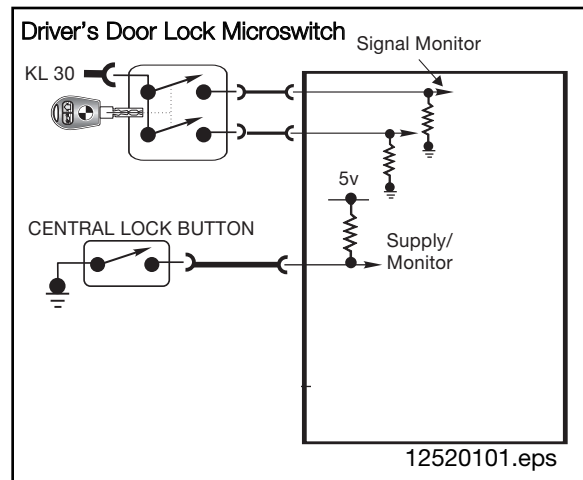

The GM **processes** the input information and contains "coded" instructions that allow a specific output control of functions.

The GM will produce **output** controls using internal transistors to switch relays allowing current flow (providing voltage or ground) through circuits and actuators. Actuators (such as relays and motors) are used by the GM to operate or control various output functions.

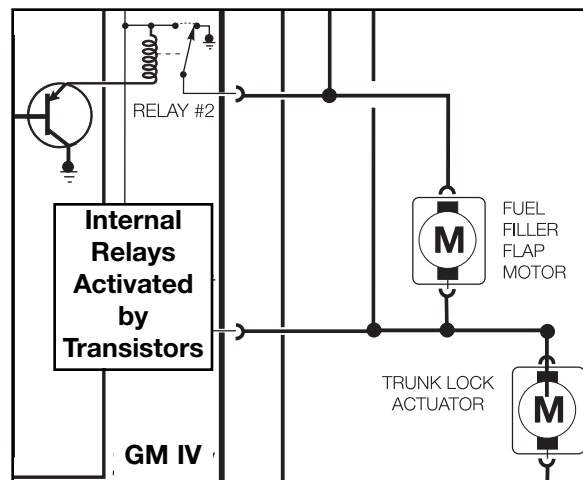

Power Distribution

The power distribution box which includes the fuses for the E36 and Z3 is located in the engine compartment.

A fuse designation label is also located on the inside lid of the fusebox. The label notes:

- Fuse rating in amps
- Location
- Circuit listing by fuse

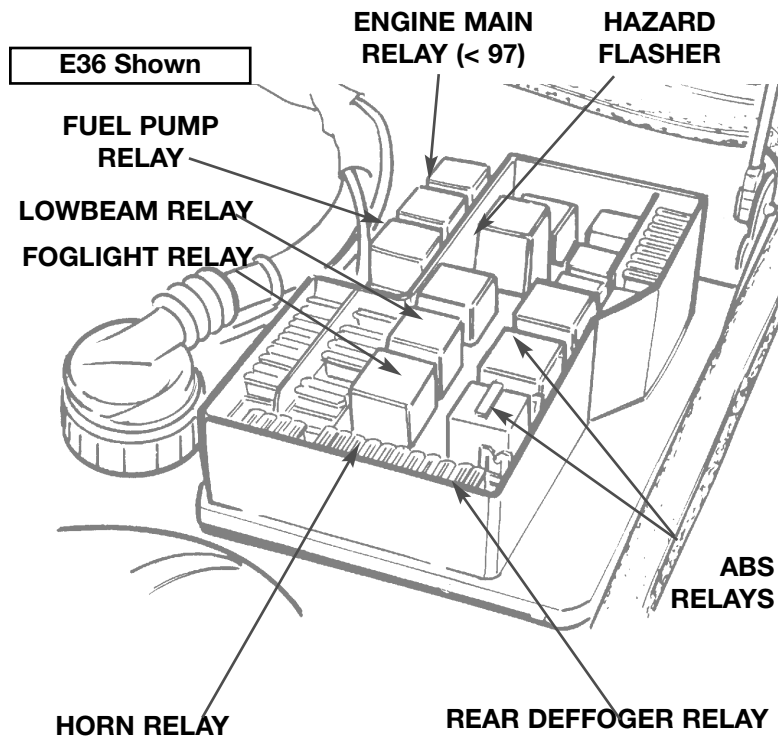

Located under and to the left of the steering column is:

- Check Control Module
- Common connector plates (splice box)
- Window/Sunroof Relay
- Crash Alarm Relay

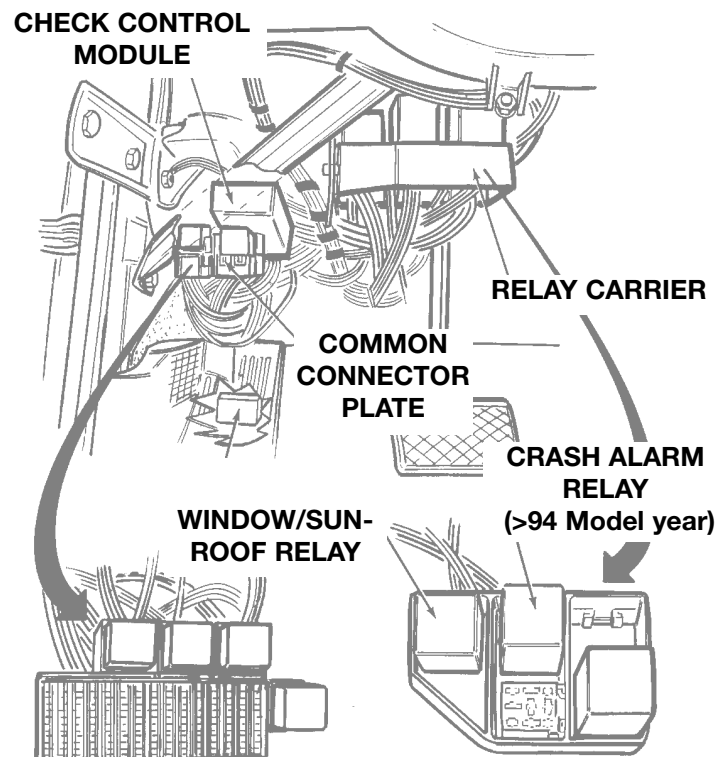

Windshield Wiping/Washing

Purpose of the System

The windshield wiping/washing functions are controlled by a separate wiper module (WWM). The system has never been directly controlled by the ZKE, even though it is a body electrical system.

The system has four wiping stages including one interval wiping speed when the ignition is in position KL R or KL15. The wiper motor output control is by the WWM located behind the glovebox.

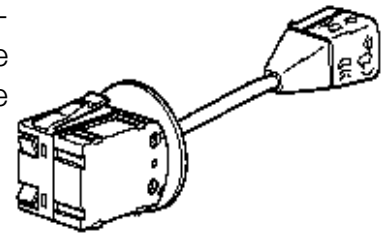

E36 Wiper Stalk

System Components

- with Principle of Operation

Wiper Stalk Switch Input

The wiping stage inputs are through a coded combination switch that supplies a ground signal to the WWM. The wiping stages include:

Single (S): Momentarily holding the wiper switch down in the single position provides a momentary ground signal to activate a single sweep in slow speed.

Slow (I) and Fast (II): The stage I and stage II wiping speeds are road speed dependent. Stage I switches to intermittent when the vehicle is stopped and stage II switches to stage I when stopped.

Windshield Washing: The wash request provides a switched ground input to the WWM by pulling the stalk rearward. The WWM activates the windshield washer pump directly. When the washing function is activated, the pump runs as long as the switch is held. The wipers switch on and will continue to for 3 wiping cycles after the switch is released.

Intermittent: The interval time of the wipers is vehicle speed dependent. As the vehicle speed increases, wiping interval times decrease. This timed interval is set in the control module and is not programmable. The programmed intermittent cycles are as follows:

0-10 mph	10-25 mph	25-50 mph	50-69 mph	69-93 mph	>93 mph
14 sec's	8 sec's	7 sec's	6 sec's	5 sec's	4 sec's

Blocking Protection

The wiper module receives a feedback signal from the wiper motor when the wipers are switched on. If this feedback signal is missing for several seconds after the wipers are switched on, the module will switch the motor off.

The wiper switch must be moved to the off position before another attempt can be made to turn the wipers on. If this blocking protection has activated several times, the ignition must be cycled before the wipers can be switched on again.

The wiper module is not connected to the diagnostic link for troubleshooting purposes. Standard troubleshooting procedures using an ETM and DISplus multimeter must be employed to diagnose the wiper/washer.

System Components: Inputs - Processing - Outputs

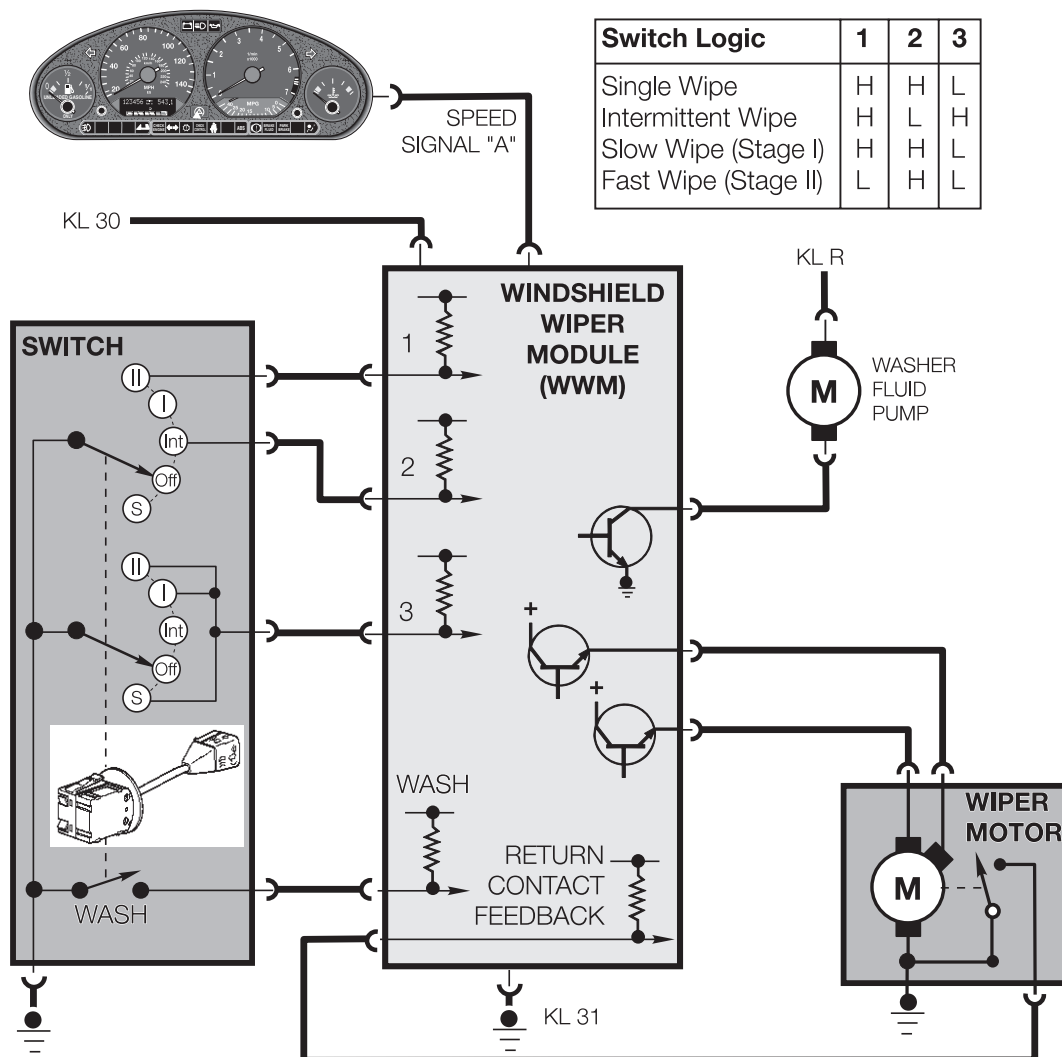

318ti Rear Window Wiper/Washer

The rear glass of the 318ti has a wiper/washer. This system has an additional set of contacts in the wiper stalk switch that operates the rear window system as well as front window wiper/washer system. Operation is as follows:

- **Intermittent Wiping:** Push the wiper switch away from the steering wheel briefly to activate intermittent wipe. Pressing a second time will switch the wiping off.
- **Wash/Wipe:** Push the lever away from the steering wheel and hold, this will activate the washer pump and the wiper as long as the switch is held.

System Components: Inputs - Processing - Outputs

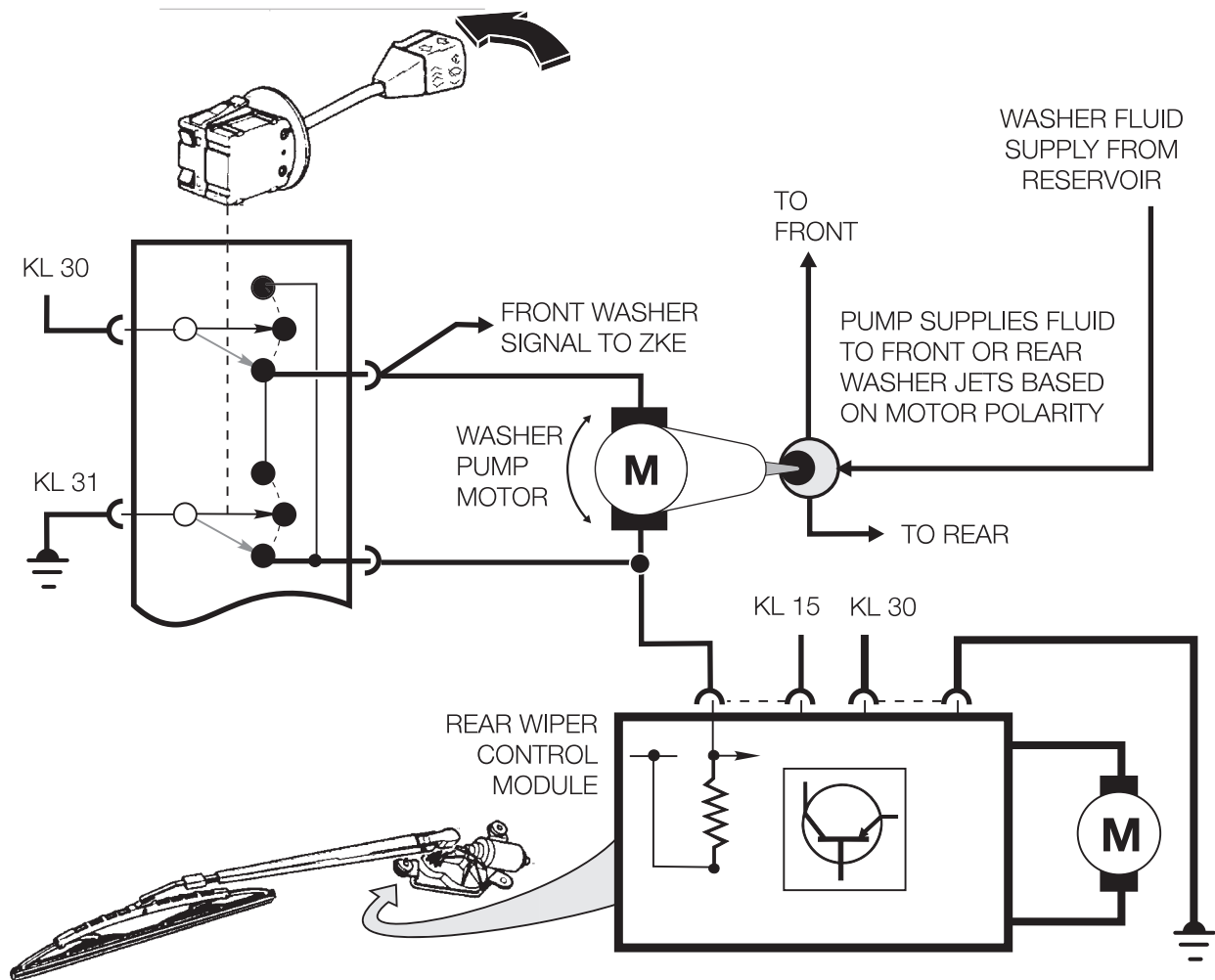

Central Locking

Purpose of the System

The Central Locking System provides locking/unlocking of the entire vehicle from one central exterior point.

From the driver's door, passenger's door or luggage compartment (>96 MY), a lock/unlock request will lock/unlock all exterior doors, luggage compartment and the fuel filler flap (*and glove box E36iC only*).

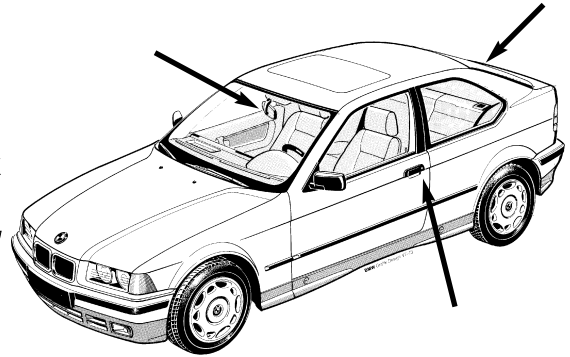

Locking from the luggage compartment lock cylinder and leaving the lock cylinder in the horizontal position will manually lock the luggage compartment in the "valet" position.

From inside, the vehicle can be locked using one of the front door lock knobs or a central locking button (>96 MY E36 which also unlocks the vehicle) located in the center console. *The doors can be unlocked by pulling twice on the interior door handle.*

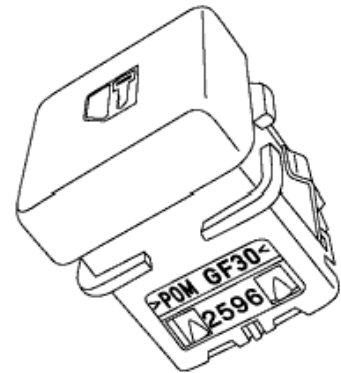

Locking the vehicle from the central switch or door lock knob will "single lock" all doors, luggage compartment and *not lock the fuel filler flap (or glovebox on the E36iC)*.

The Central Locking System utilizes the GM IV to carry out all of the locking/unlocking features:

- When locked from the outside, the vehicle will double lock and arm the alarm system (only if equipped with DWA, not the accessory Alpine Alarm). The ignition must be switched off and the driver's door must be opened and closed.
- The EWS II is interfaced for double lock monitoring and unlock function(>1/95 Production Date). With the presence of an accepted EWS II key and switching the ignition "on", the GM IV will unlock the vehicle.
- In the event of an accident (ignition must be switched on), the GM IV will be signalled to unlock all of the doors.

- Anti-theft drive away protection feature with double lock (>1/95 Production Date when locking the vehicle from the exterior).
- Comfort closing of the windows is possible from both front door locks if held in the lock position.
- 1996 E36 - Sunroof added to comfort closing feature.
- E36iC - The trunk is locked out when the convertible top is in operation. Fully automatic convertible top added to comfort closing feature (97 MY and later vehicles).

Hardware Features

- The door lock buttons are mechanically uncoupled from the lock actuators when locked. The door lock buttons also “mechanically” lock the individual doors. This provides manual locking in the event of a central locking malfunction.
- Child safety locks (located in the rear doors on a four door vehicle) are actuated by sliding a lever. The door can now only be opened from outside.
- The luggage compartment can be manually locked with a “Master Key” and leaving the lock cylinder in the horizontal position which prevents opening by any other method (secured for valet).
- The Fuel Filler Flap mechanical release is found in the right side of the luggage compartment.
- The glove box has a lock cylinder to secure the contents by manual locking with a “Master Key” and leaving the lock cylinder in the horizontal position which prevents opening by any other method (secured for valet).

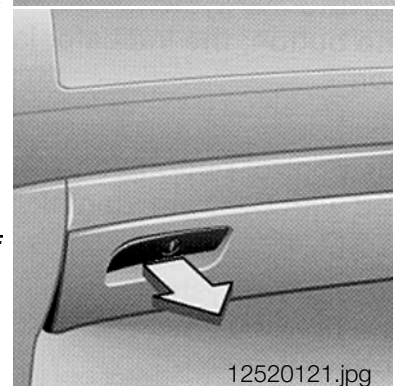
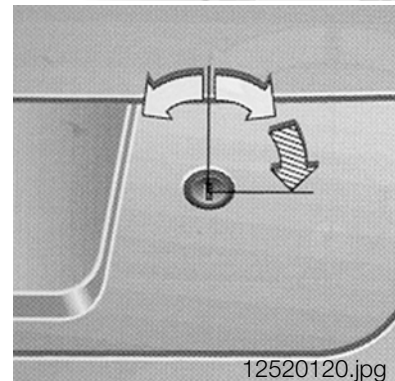
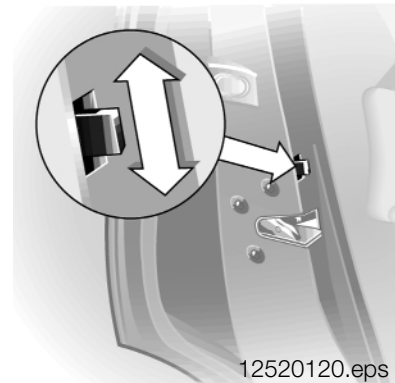

The valet key is not mechanically capable of entering either of these lock cylinders.

Central Locking - ZKE IV

The locking and unlocking of the lock actuators is controlled from three relays in the GM. The door lock actuator "Pin Contacts" and lock micro-switches provide the inputs to the GM for locking/double locking and unlocking of the doors, trunk, fuel filler flap (and glove box on the E36iC only). The relays in the GM provide both power and ground depending on the direction of actuator movement (lock/unlock).

System Components: Inputs - Processing - Outputs

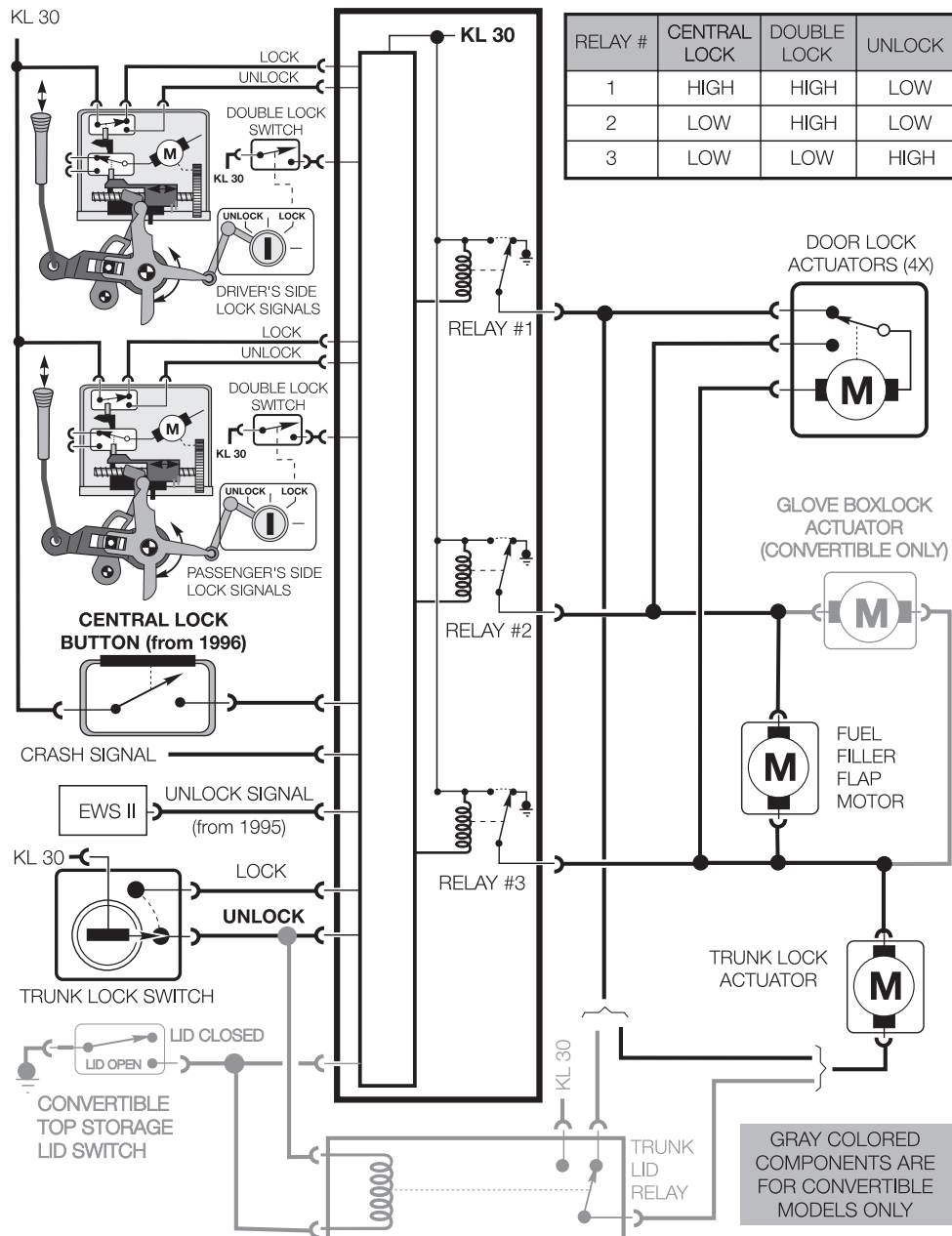

Lock Actuator Operation

The lock actuators contain the electrical motor drive, the lock/unlock switch contacts and the integral single/double lock limiting switch.

The actuators control the mechanical locking/unlocking function of the doors by sliding two protruding levers. The precise positioning of the levers provides the unlock, single lock and double lock positions of the latch mechanism.

The electro-mechanical operation of all the lock positions are provided on the following pages:

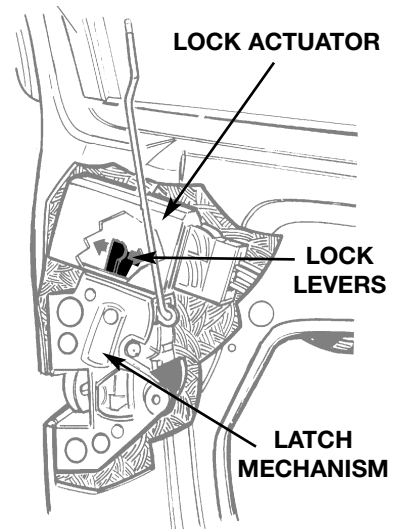

UNLOCKED-NEUTRAL POSITION

UNLOCKED-NEUTRAL POSITION

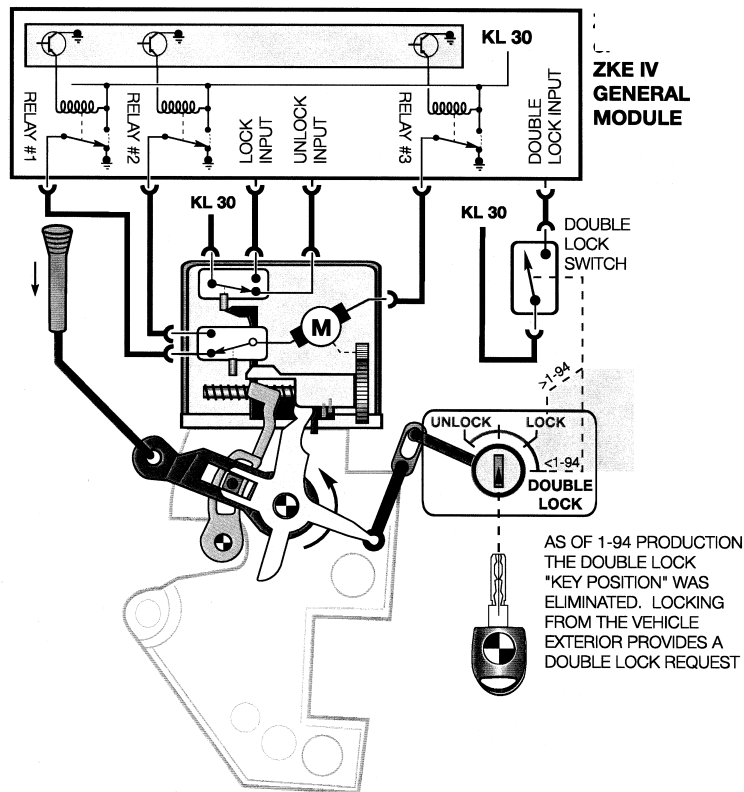

- All switch contacts are in their rest positions.
- The lock actuator/latch mechanisms are in the unlocked position.
- Raising the door handle or pulling the interior door latch will mechanically open the door.

Central Locking System Terminology

“Single lock”, “Central lock”: Vehicle is locked via the lock knob, or the console mounted central lock button (>12-95 prod).

“Double lock”, “Central arrest”: Vehicle has been locked from the exterior with the key at the driver’s door, passenger’s door or trunk.

SINGLE LOCK - Phase 1, mechanical lock at door and lock signal generation

SINGLE LOCK - Phase 1, mechanical lock at door and lock signal generation

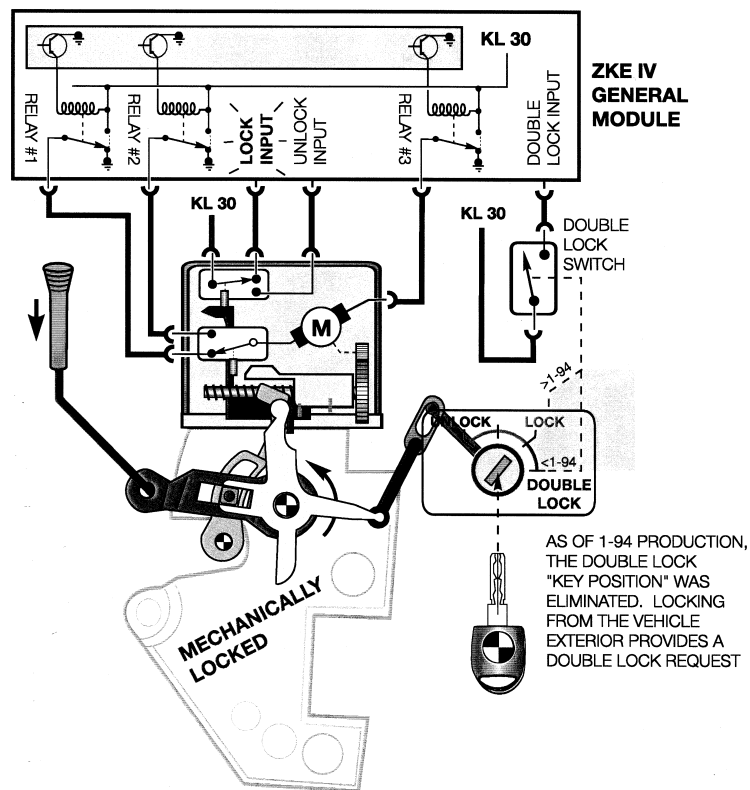

- The lock button and key mechanically rotate the lock lever which decouples the exterior door handle from the latch.
- When rotated, the lock lever also slides an internal switch ramp to the left closing the lock microswitch.
- This provides the lock signal to the GM (cont'd on next page.)

SINGLE LOCK - Phase 2, activation of actuators at all door locks

When the GM receives the lock signal it activates internal relay #1, providing power through the closed single lock contact to the actuator motor. Ground is provided through the module's closed contact of relay #3.

All of the vehicle's actuator motors are energized until the single lock circuit is opened by the gear driven slider. The actuators stop at the single locked position.

At this point, the external door handles are decoupled from the latch mechanism preventing entry from outside of the vehicle.

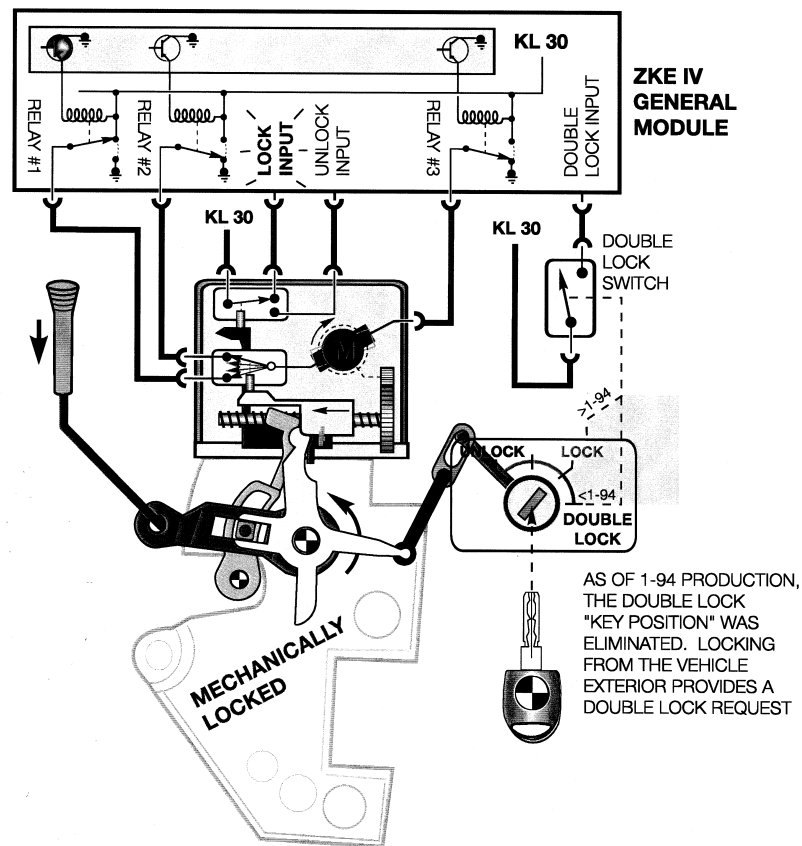

If the internal door handle, the lock buttons or the central lock button on the center console are operated, the door returns to unlock mechanically and can be opened.

DOUBLE LOCK - Electrical Activation

Turning the key from any outside lock cylinder causes the external double lock micro-switch to close. The GM recognizes this high signal as a double lock request.

The GM activates internal relay #2, providing continued motor operating power through the closed contacts of the internal double lock circuit. Ground is provided through the GM's internal relay # 3. The actuator motors are energized until the internal double lock circuit is switched back to the single lock circuit by the gear driven slider.

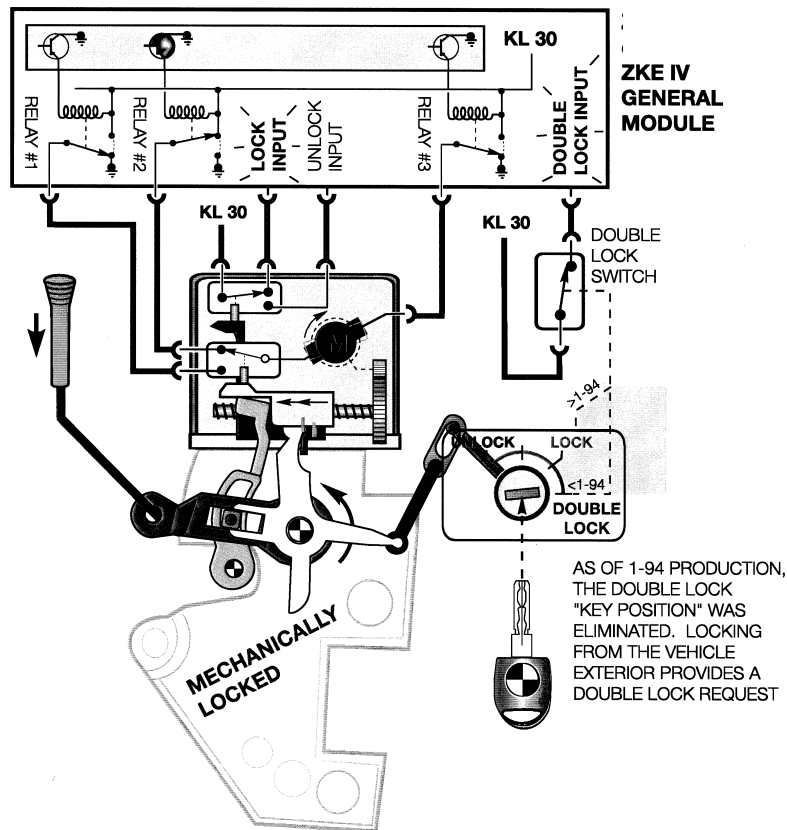

Notes: _____

DOUBLE LOCK - Mechanically Decoupled

When the slider switches the circuit back to single lock it also pushes the double lock lever to the left until it stops. In this position, the double lock lever decouples the lock button from the latch mechanism. The lock button can be pulled but will not unlock the door since it is not coupled to the mechanism. Spring pressure pulls the button back down when released.

At this point, unlock is only possible when a key is turned to the unlock position from an outside door lock or if the GM receives the unlock signal from the EWS II control module.

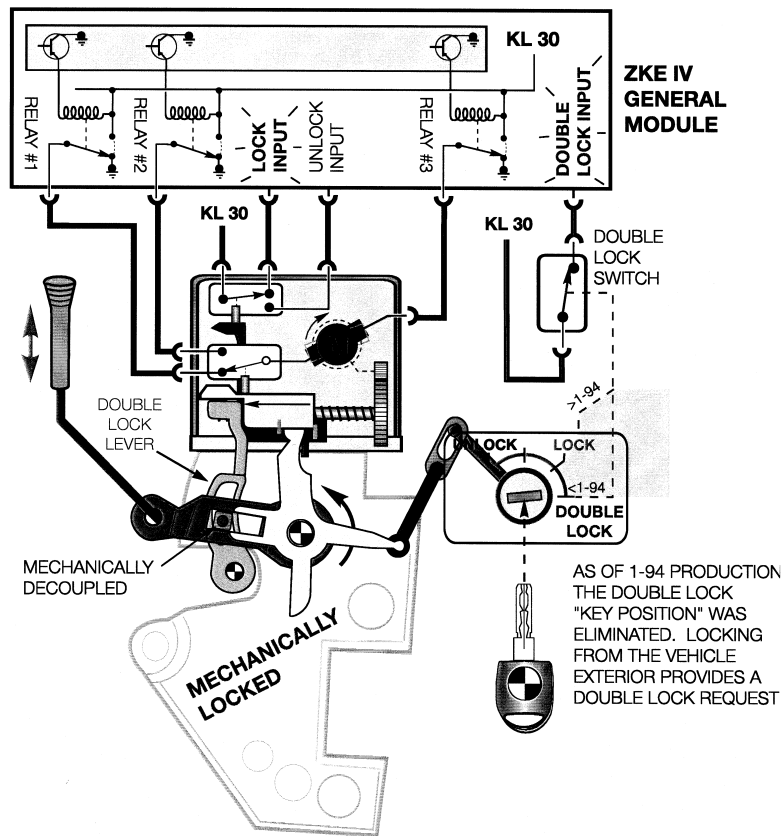

Notes: _____

UNLOCK FROM DOUBLE LOCK

When the GM receives the unlock request from a key location it activates internal relay #3 providing operating power to the actuator motor in the opposite direction.

The single and double lock circuits (internal relays 1 & 2) are not activated at all during the unlock function providing ground for the motor to bring the actuator back to the fully unlocked position.

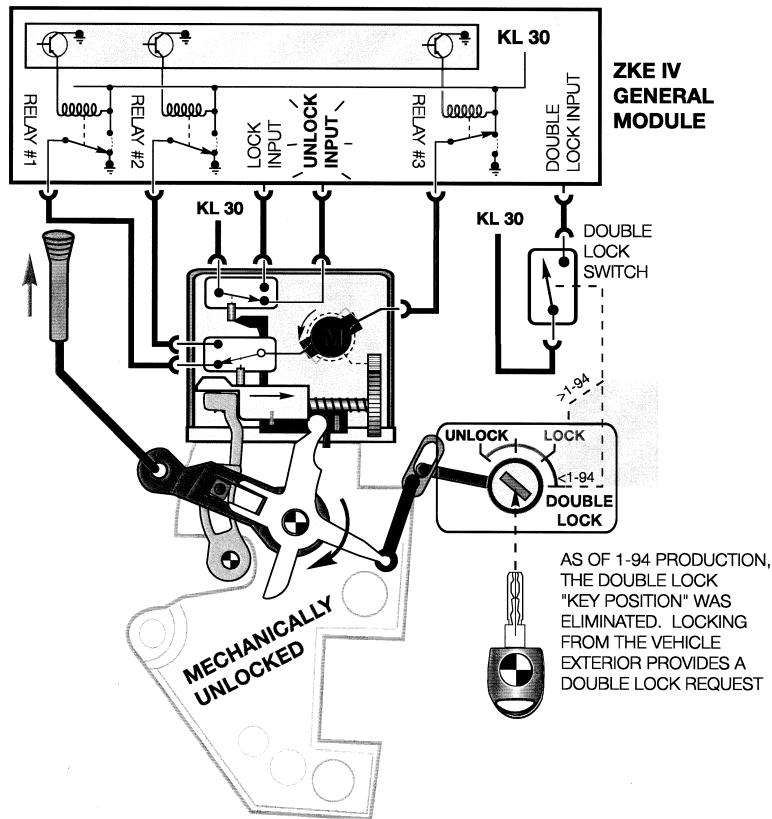

Notes: _____

Locking Protection

Power protection for the door locking circuit is provided by a “time monitored” activation of the door lock actuators by the GM. The door lock actuators are provided power for the duration of time needed to run the actuator to the desired position.

- The maximum on time for the actuators is 0.7 seconds.

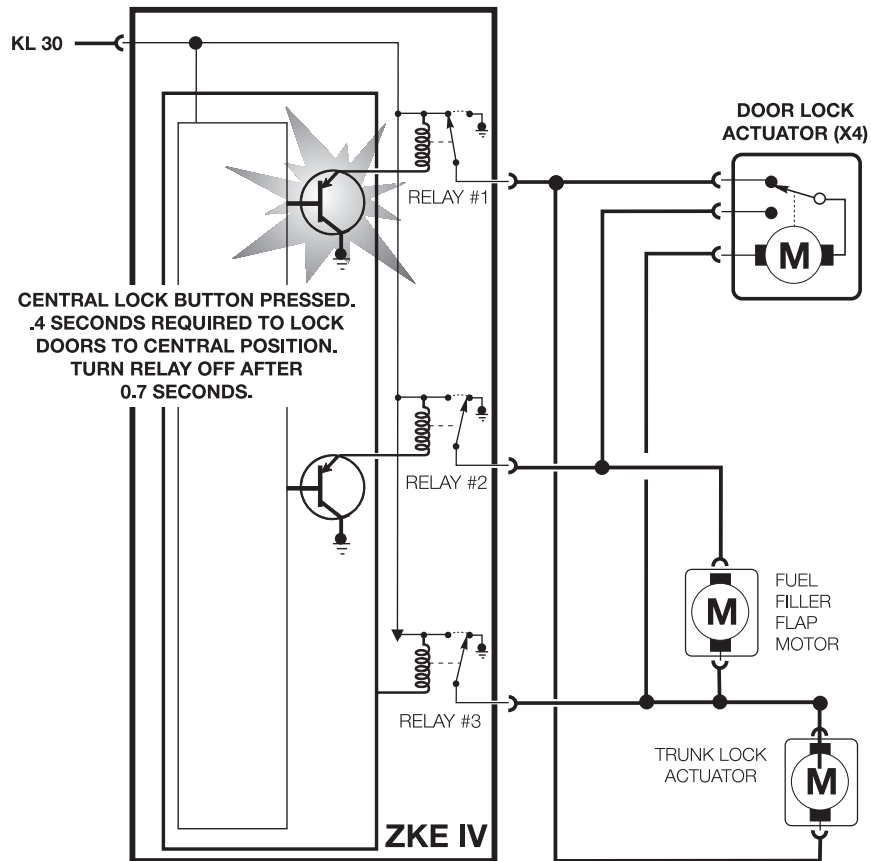

Crash Signalling

The Supplemental Restraint System control module provides a switched signal to the GM in the event of an accident. This signal was previously provided by the Crash Alarm located in the left front kick panel on earlier models (<97 MY).

The signal is an output function of the control module and becomes active when the impact threshold has been exceeded. The GM unlocks the vehicle, switches on the interior lights and signals the Crash Alarm Relay to flash the exterior lights when this signal is active.

Door Lock Heating (optional)

Purpose of the System

The *Driver's door lock cylinder* is surrounded by a heating coil to warm the lock cylinder in case it is frozen due to moisture and below freezing temperatures.

Principle of Operation

The GM controls the lock heater by providing voltage through a final stage transistor. The heater is switched on by raising the driver's door handle. Prerequisites for heater operation include:

- Vehicle locked
- Door handle raised for approximately 3 seconds

Power is applied to the heater for a maximum of 32 seconds. A timed arrest of 16 minutes is activated after 3 heating attempts. The door lock heater is switched off immediately after unlocking the door.

System Components: Inputs - Processing - Outputs

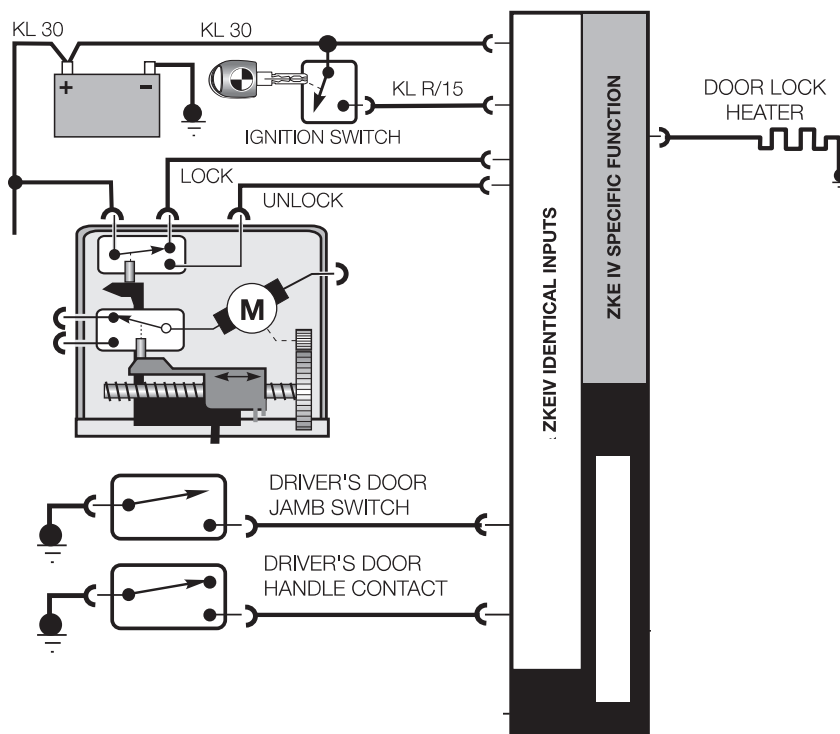

Power Windows/Sunroof

Purpose of the System

The features of the power windows and sunroof system include:

- One-touch operation in both directions (up/down) on the front windows, down only on the rear windows.
- Anti-trap detection is on the front windows only (initialization required for one touch operation).
- The control of the rear windows is carried out through a Relay Module (RM IV).
- The switches in the center console controls all four windows and the rear window lock out feature.

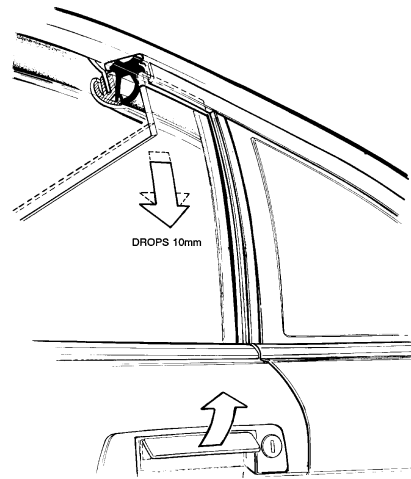

Principle of Operation

All window operation request signals are digital inputs to the GM.

- Comfort Closing of the windows from the driver's or passenger's lock cylinder when held in the locking position.
- When the ignition key is in accessory or "ON" press the switch to open or close the windows. Window operation is possible with the ignition switched off until a front door is opened or 16 minutes (maximum) has elapsed.
- Power protection against a jammed or seized motor is monitored by the hall sensors in the window motors. The GM will interrupt the power to a jammed motor. Rear windows utilize current sensing for shut off.
- The one-touch function is activated by momentarily pressing the window switch to the second detent. Window travel will cease when the full up or down position has been reached. One-touch can be canceled by pressing the window switch a second time. Anti-trap is provided by the GM monitoring the door glass movement from the hall sensor. If the door glass encounters resistance in the closing direction ($>100\text{Nm}$) the motor will stop and reverse direction for 50 mm of travel.

Window Operation specific to the E36 Convertible:

- Central Window Switch: Located in the center console, the switch will raise or lower all four windows at the same time. The window lowering has the one-touch feature.
- Convertible top operation: Prior to lowering the top, the top control module signals the GM to lower all four windows half way.
 - If the top switch is held after the top is fully lowered, the windows will close fully.
 - If the top switch is held after the top is fully closed the GM will close the windows.
- With the introduction of the fully automatic convertible top, the comfort close feature of the convertible was also added.



Window Operation specific to the Coupe, Convertible and Z3 Coupe:

The design of the E36 Coupe, Convertible and Z3 Coupe required changes in the window operation.

- When opening the door, the door glass is automatically lowered by approximately 10mm. When the door latch opens (switch closes), the window will drop. It remains down until the door contact switch opens when the door is closed. The window will then raise back into the door seal.
 - When the door is closed, the glass is raised back into the seal.
- This allows the glass to drop out of the door seal when opening the door and provides a tighter seal when the door and glass are closed.
- The window motor contains a Hall sensor for this feature that is monitored by the GM.

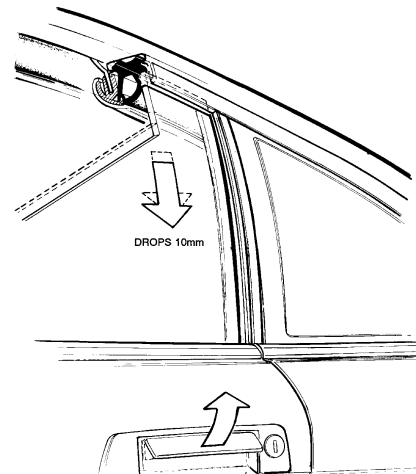

System Components

Window Switches: The signals from the window switches are monitored by the GM.

The power window switches have a second detent position for the purpose of signalling the one touch feature.

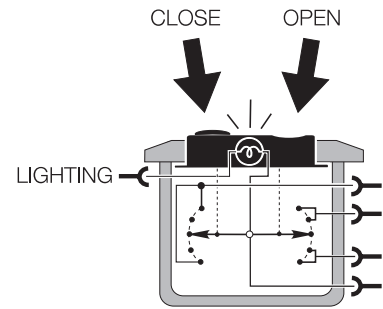

Relay Module: The RM IV was added for rear window operation in the 4 door and convertible models only.

Similar to the front window relays in the GM, the Relay Module contains the relays for the rear window motors on these vehicles.

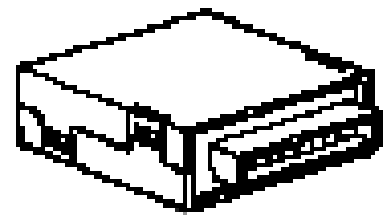

The RM IV is located behind the glove box in the electrical carrier next to the GM.

System Components: Inputs - Processing - Outputs

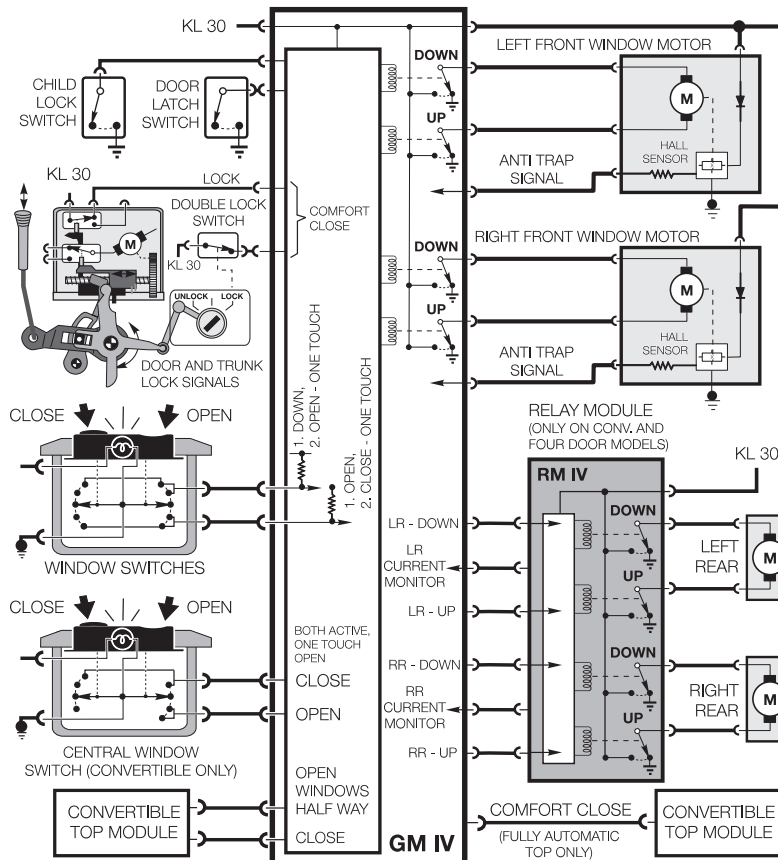

Initialization of Window Circuits

Initialization of the window circuits is required for the one-touch and anti-trap features to function. Closing the window and holding the switch for an additional two seconds will initialize the system. However the window drive motor switches off automatically after the motor ceases rotation for approximately 0.3 seconds.

Sunroof

Purpose of the System

When the ignition key is in the accessory or “on” position press the switch to lift (1), close the sunroof (2) or open the sunroof (3).

When lifting, the headliner retracts several inches. The sunroof can continue to operate after the ignition has been switched off (up to 16 minutes) as long as one of the front doors has not been opened.

E36 vehicles are equipped with the steel roof while the Z3 Coupe is equipped with the glass (moon) roof. Mechanically, the sunroofs are similar in design.

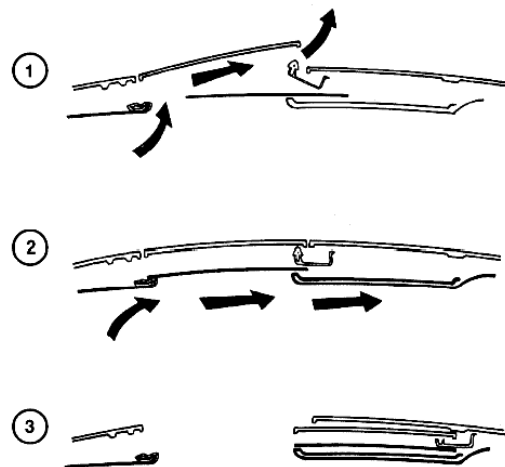

Principle of Operation

The motor incorporates a sunroof module (>96 MY) which receives inputs from the sunroof switch (1) for operation. This sunroof system has the one touch open function.

The sunroof module is linked to the GM for two purposes:

- The comfort closing feature when the key is held in the lock position in one of the door lock cylinders.
- Unloader signal. This signal (30h) informs the sunroof motor module to stop running the sunroof motor when the GM receives a start signal (KL 50).

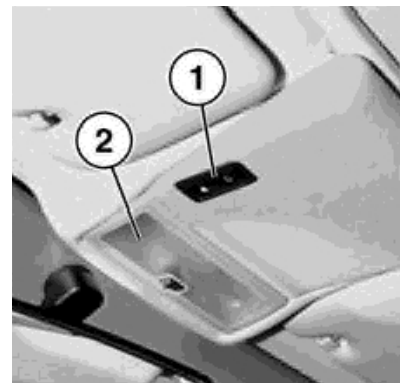

System Components: Inputs - Processing - Outputs

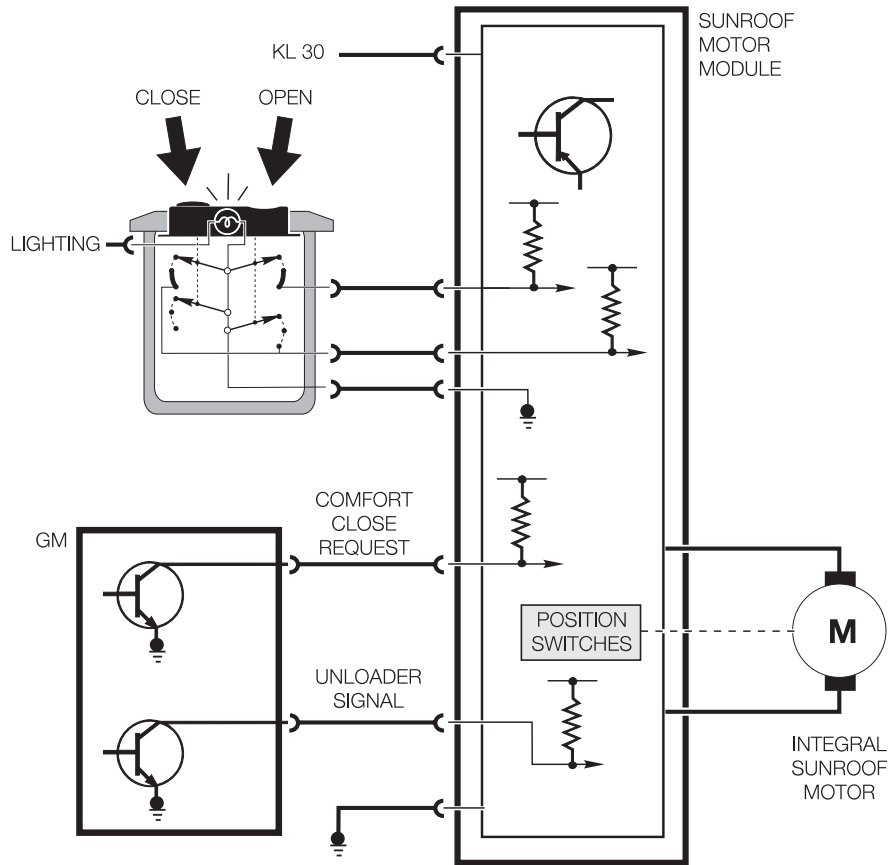

Notes: _____

Interior Lighting

Purpose of the System

The GM controls the interior lighting automatically with the status change of several monitored inputs.

The lighting can also be manually controlled using the interior light switch (2).

In addition to the various time controls, the interior lights are also subject to the 16 minute shut down of the GM (consumer protection).

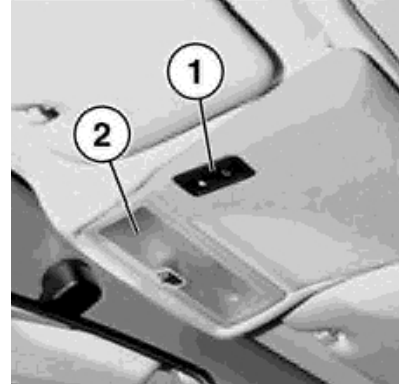

Principle of Operation

The interior light switch is a rocker switch that will activate the interior lights “On or Off” (left/right positions). When the light switch is in the center position (automatic):

- If the interior lights are switched “ON” by the button with the ignition switched **ON**, the interior lights will remain on until they are switched off by the button.
- If the interior lights are switched “ON” when the ignition is switched **OFF**, the lights will remain on for 16 minutes (consumer cutout).
- Locking the vehicle from the outside will immediately switch off the interior lights.

The ON/OFF conditions for the interior lights in the automatic mode are as follows:

ON Conditions

- Door Open.
- Switching off ignition after exterior lights have been switched off.
- Crash Alarm/MRS input.

OFF Conditions

- All doors closed with ignition on.
- All doors closed with ignition off after 20 seconds.
- 20 seconds after switching off ignition with lights off.
- 8 seconds after switching the ignition off.
- 16 minutes with door(s) open.
- When doors are locked.

System Components: Inputs - Processing - Outputs

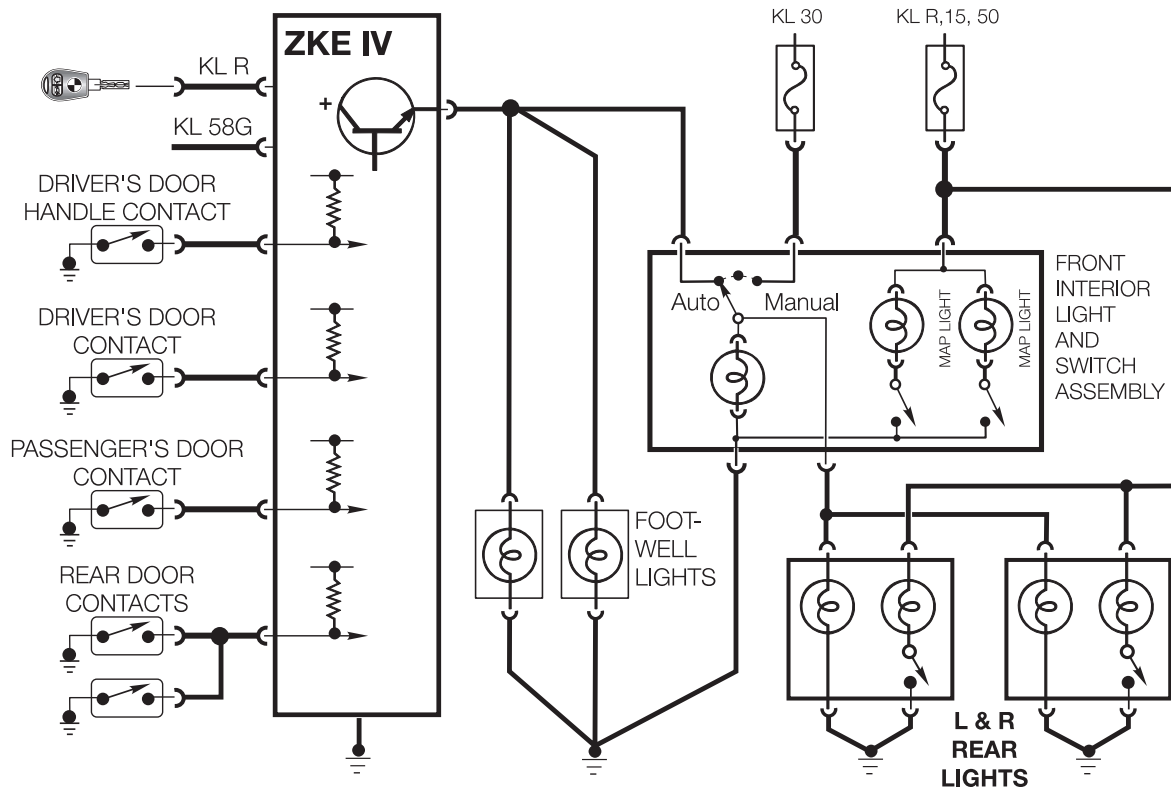

- The GM in 3 Series convertibles provide power to the manual circuit of the interior lights (See the Consumer Cutout feature).
- Through the production range there are minor changes in the lighting fixtures.

For example: the additional map light switch on rear seat interior lights on 1997 models. Always refer to the specific ETM for the vehicle being serviced.

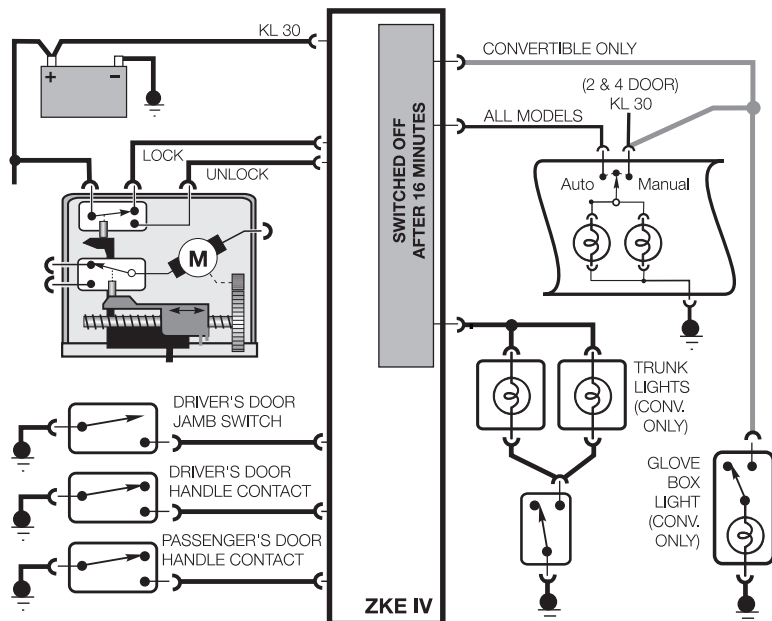

General Functions of ZKE IV

Consumer Cut Off

The Consumer Cut Off function interrupts battery voltage to circuits preventing inadvertent battery drain if one of the consumers were to remain activated. The GM will deactivate the interior lights after 16 minutes if one of the doors is left open. Convertibles also have the following lighting circuits controlled by this feature:

- Glove Box Light
- Trunk Light

The circuit will switch back on when any monitored wake up trigger such as the door contacts or the lock/unlock signals become active.

Overload Protection

The Central Locking circuit of the GM is protected against overloads and short circuits by the electronic Overload Protection which is an integral part of the GM.

- Power protection for the door locking circuit is provided by a “time monitored” activation of the door lock actuators by the GM. The door lock actuators are provided power for the duration of time needed to run the actuator to the desired position. The maximum on time for the actuators is 0.7 seconds.

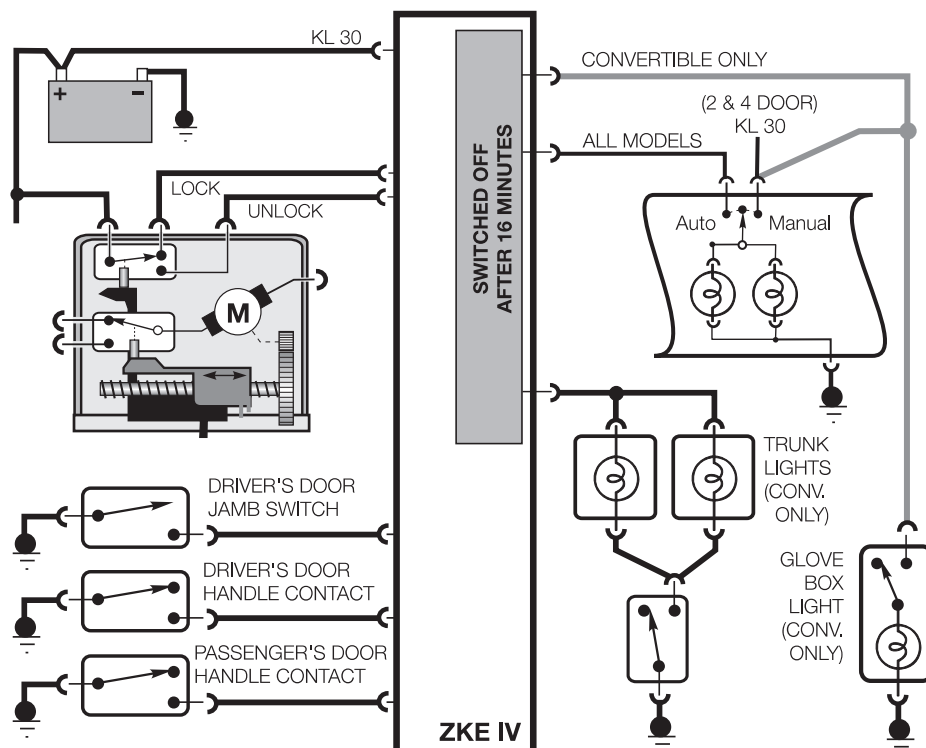

Review Questions

1. List the functions directly controlled by the GM IV. _____

2. How does the GM IV recognize the key position from the drivers door? _____

3. What is the "Comfort Closing" feature? _____

4. Describe the differences between "single" and "double" lock regarding the lock actuators. _____

5. What circuits are controlled by Consumer Cut Off? _____

6. What functions will deactivate the Interior Lighting? _____

7. Describe Blocking Protection: _____

8. What affect does EWS have on the Central Locking System? _____

