

---

# Table of Contents

## Engine Cooling/Heating System

| Subject  | Page |
|--|------|
| Introduction .....                             | 3    |
| Heat Management .....                          | 5    |
| Intelligent Heat Management .....              | 6    |
| Engine Cooling/Heating System Components ..... | 7    |
| The Radiator .....                             | 7    |
| Engine Coolant .....                           | 9    |
| Coolant Recovery Tank .....                    | 9    |
| Coolant Level Check .....                      | 9    |
| Cooling Fans .....                             | 10   |
| Coolant Pump (Mechanical) .....                | 12   |
| Third Generation Design .....                  | 13   |
| Coolant Pump (Electric) .....                  | 14   |
| Electric Pump System Bleeding Procedure .....  | 16   |
| Conventional Thermostat .....                  | 17   |
| Data-map Thermostat .....                      | 17   |
| Control Principle of Datamap Thermostat .....  | 18   |
| Water Valves .....                             | 19   |
| Air Cleaner/Microfilters .....                 | 19   |
| Heater Core .....                              | 20   |
| Blower Fan .....                               | 21   |
| Blower Control .....                           | 23   |

---

# Engine Cooling/Heating System

Model: All

Production: All

## OBJECTIVES

After completion of this module you will be able to:

- Describe the operation of the engine cooling system.
- Identify the components that integrate the engine cooling system.

# Introduction

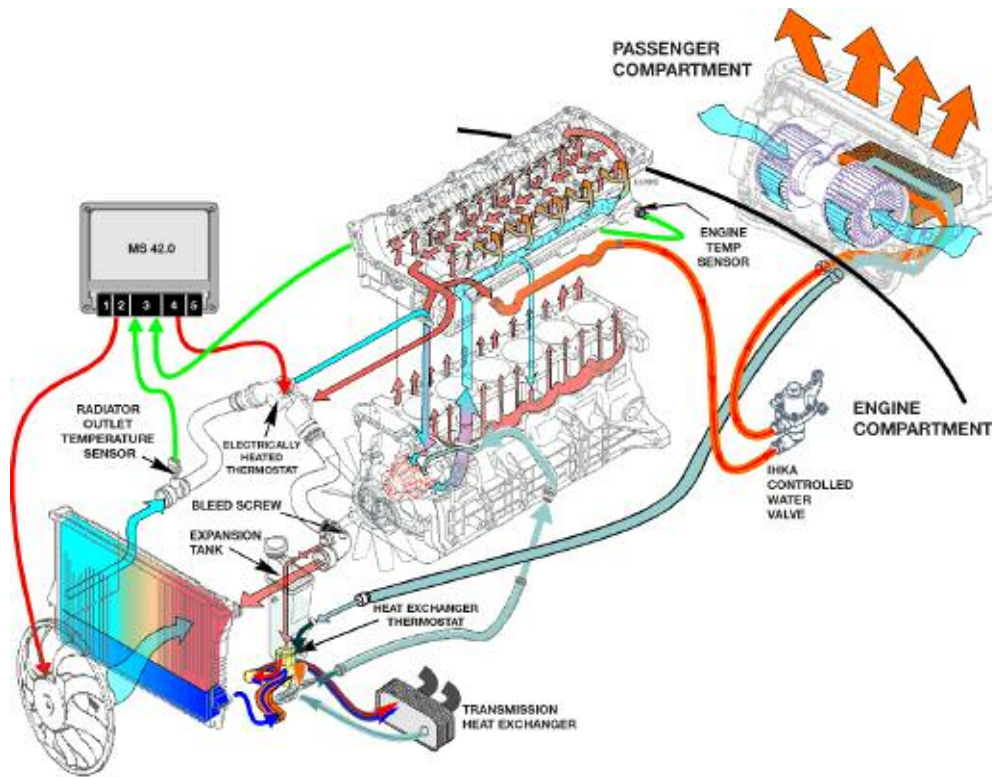

The internal combustion engine transforms chemical energy into mechanical energy. Heat is generated as a by-product of combustion and by internal component friction. Maintaining operating temperature is crucial for the operation and efficiency of any engine. Temperatures in excess of the operating temperature may lower efficiency, raise emissions levels and eventually lead to engine failure.

The job of the cooling system is to circulate a coolant mixture of antifreeze and water through the engine with the purpose of extracting excess heat but at the same time allowing the engine to achieve and maintain operating temperature. This ensures maximum efficiency, lowers tailpipe emissions and contributes to engine durability by minimizing wear.

The coolant is circulated through the engine block and cylinder head with the use of a belt driven or electric water pump. This pump pushes the coolant through a thermostat to the radiator where a cooling fan forces ambient air through the outside fins of the radiator to extract heat from the circulating coolant. The thermostat is held closed for a sufficient amount of time to allow for adequate heat transfer to take place on both sides (hot or cold) of the system. The coolant in the cooled section of the radiator may also be used for other cooling needs like transmission oil cooler or engine oil cooler before it is re-circulated back into the engine and the process is repeated.

The cooling system is pressurized with the use of a metered radiator cap. This pressurization of the coolant raises the coolant boiling point and allows the system to operate at much higher temperatures without boiling over. It is designed to maintain the pressure inside of the system. Sending the excess coolant to an expansion tank as the heated coolant expands and letting it re-enter the system when the engine cools down and the coolant contracts. In this manner the cooling system remains sealed and full.

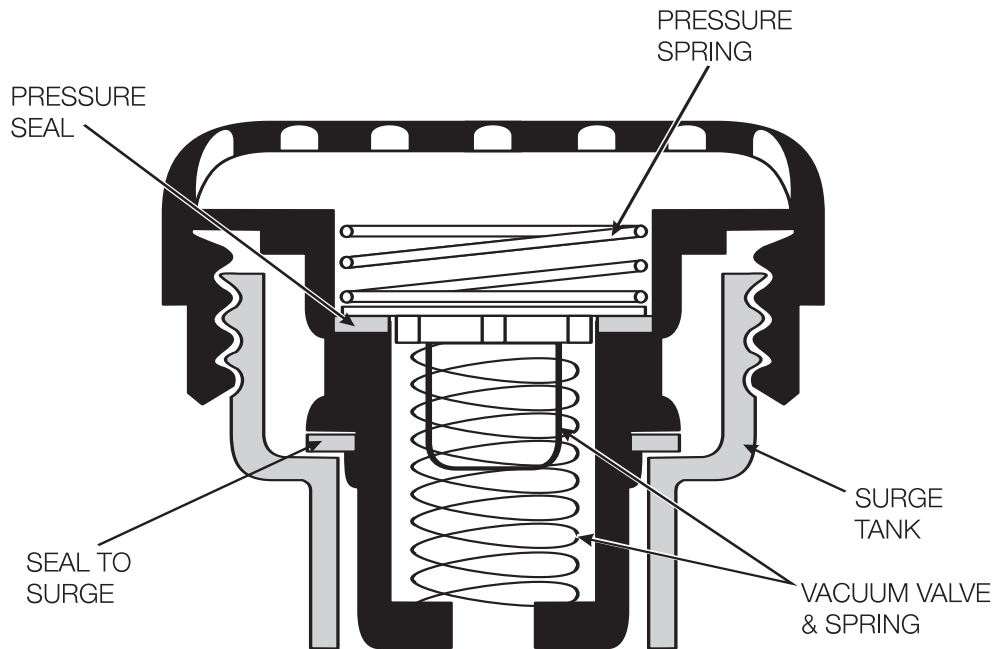

Hot coolant from the engine/cylinder head is sent into the passenger compartment to be circulated through a heat exchanger (heater core). This heat supply warms the passenger compartment as a blower fan flows air through the outside fins of the heater core, extracting heat from the circulating coolant. The desired temperature is generally controlled through the use of a heater control valve.

To optimize system efficiency a computer monitors the engine coolant temperature to operate the cooling fan, thermostat opening and electric water pump. The computer alters its modes of operation depending on the feedback from the coolant temperature sensor. Limiting the engine capability until operating temperature is reached and stepping in to safeguard the engine if operating temperature is dangerously exceeded.

At BMW, there have been three types of water cooling systems used to date:

- Simple water cooling system
- Partially-cooled-engine water cooling system
- Crossflow water cooling system

Note: For detailed information on cooling systems refer to the Engine Reference Material under Cooling Section.

---

## Heat Management

The engine management ECU controls the coolant pump as demanded by the situation as follows:

- Low output when cooling requirement is small and outside temperatures are low.
- High output when high cooling requirement is large and outside temperatures are high.

The coolant pump may also be completely switched off under certain circumstances, e.g. to allow the coolant to heat up rapidly during the warm-up phase. However, this only occurs when no heating is required and the outside temperature is within the permitted range.

The coolant pump also operates differently than conventional pumps when controlling the engine temperature. Previously, only the currently present temperature could be controlled by the thermostat. The software in the engine control unit now features a calculation model that can take into account the progression of the cylinder head temperature based on load. In addition to data-map control of the thermostat, the heat management system makes it possible to use various data maps for the purpose of controlling the coolant pump.

For instance, the engine management ECU can adapt the engine temperature to match the current driving situation. This means that four different temperature ranges can be implemented:

- 111°C (231°F) ECO mode
- 105°C (221°F) Normal mode
- 95°C (203°F) High mode
- 80°C (176°F) High + Data-map thermostat mode

If the engine management ECU selects ECO mode based on the current operating conditions, the system aims to bring about a higher cylinder head temperature (111°C/231°F). The engine is operated with relatively low fuel consumption in this temperature range as the internal friction is reduced. An increase in temperature therefore favors lower fuel consumption in the low load range. In High and

Data-map thermostat mode, the driver wishes to utilize the optimum power development of the engine. The cylinder head temperature is therefore reduced to 80°C (176°F). This results in improved volumetric efficiency, thus increasing the engine torque. The engine management ECU can then set an operating mode adapted to the particular driving situation. Consequently, it is possible to influence fuel consumption and power output by means of the cooling system.

---

## Intelligent Heat Management

The previous section explained the operating modes in which heat management was implemented. However, an electrically driven coolant pump makes even more options possible. For instance, it is now possible to warm up the engine without the coolant circulating, or to allow the pump to continue running after the engine is switched off in order to facilitate heat dissipation.

The advantages offered by this type of pump are listed below:

### Fuel consumption

- Faster warm-up as coolant is not circulated (stationary).
- Increased compression ratio through greater cooling capacity at full load compared to the predecessor engine.

### Exhaust emissions

- Faster engine warm-up due to drastically reduced pump speed ( $n \Rightarrow 0$ ) and the resulting minimal volumetric flow of coolant.
- Reduced friction.
- Reduced fuel consumption.
- Reduced exhaust emissions.

### Power output

- Component cooling independent of engine speed.
- Demand-based coolant pump output.
- Avoidance of energy loss.

### Comfort

- Optimum volumetric flow.
- Greater heater output when demanded.
- Residual heat when engine is not running.

### Component protection

- Electric pump overrun achieves more effective heat dissipation after switching off engine when hot.

# Engine Cooling/Heating System Components

## The Radiator

The radiator is the main heat exchanger responsible for dissipating the heat gathered by the coolant as it circulates through the engine and cylinder head. The hot coolant is pushed into the radiator with the use of a water pump and a cooling fan blows outside air through it to cool it off. Today radiators are built out of Aluminum and plastic.

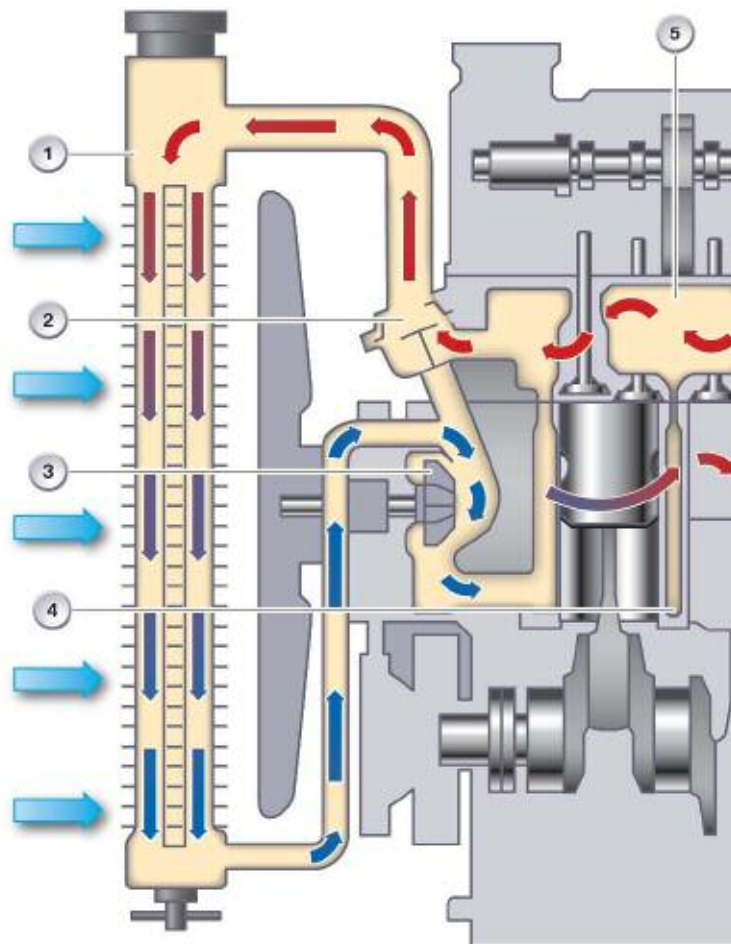

| Index | Explanation               |
|-------|---------------------------|
| 1     | Radiator                  |
| 2     | Thermostat                |
| 3     | Coolant Pump              |
| 4     | Coolant Passages in block |
| 5     | Coolant Passages in head  |

---

The radiator on the E65, is all aluminum and is divided into two sections: a high-temperature section, which is mainly responsible for engine cooling, and a low temperature section, which takes care of automatic-transmission oil cooling. This is achieved by a diverter integrated in the radiator tank which diverts part of the coolant flow adjacent to the high temperature section.

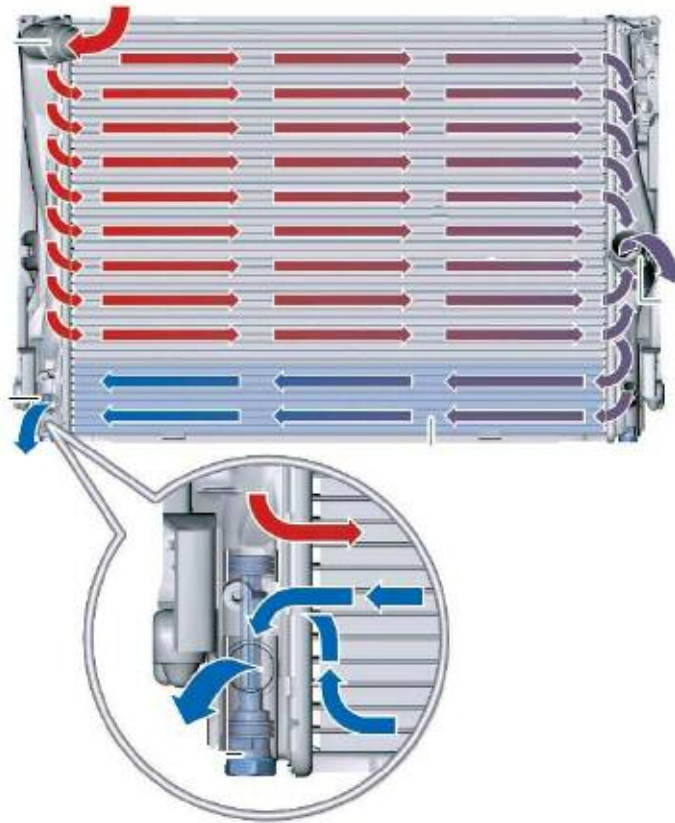

In comparison with the plastic/aluminum radiator used on the previous models, it is 400 g lighter when full and 21mm slimmer. The total weight reduction is around 5 percent.

The all aluminum radiator is not only slimmer, it is also more reliable and lasts longer than conventional radiators. The all-aluminum design also for the first time incorporates VDA connections for quick-fit joints.

Note: Manual Transmission vehicles utilize the entire radiator surface for engine cooling.



---

## Engine Coolant

The cooling system contains a special liquid called coolant, or "antifreeze," which circulates through the engine and the radiator. The coolant picks up heat from the engine and transports it to the radiator, where it is dissipated to outside air. Some of the hot coolant can also be circulated through the heater core, where it can warm the air being blown into the passenger compartment.

The antifreeze concentration should be 50%, throughout the year. In addition, the coolant should be drained and refilled according to the recommendations in the BMW Operating Fluids Specifications, Group 17.

The cooling system does not need any additives besides a reputable brand of ethylene glycol antifreeze with corrosion inhibitors that are nitrite- and amino-acid free and compatible with aluminum radiators. Antifreeze other than the type specified by BMW for aluminum radiators may cause corrosion of the cooling system, which can lead to engine overheating and damage.

## Coolant Recovery Tank

As coolant is heated it expands and gains volume, this fluid expansion is contained in the coolant recovery tank or expansion tank. Generally constructed out of plastic, this reservoir catches and holds the coolant as the engine warms, stores it until the engine cools and the suction generated by the contraction of the coolant pulls it back into the system.

## Coolant Level Check

Coolant level can be checked by observing that the fill line is between a minimum and a maximum (Hot) marker and filling according to specifications. A measuring device or sensor is generally provided to indicate coolant level depending on the model.

Illustration shows E60/E61/E63/E64:

- Perform filling operation slowly. Pour coolant into expansion tank up to MAX mark.
- Start engine and run at idle speed for approx. one minute (cap open). Then adjust coolant level to MAX.
- Close cap and run engine up to operating temperature until main thermostat opens. Check cooling circuit and drain plug for leaks

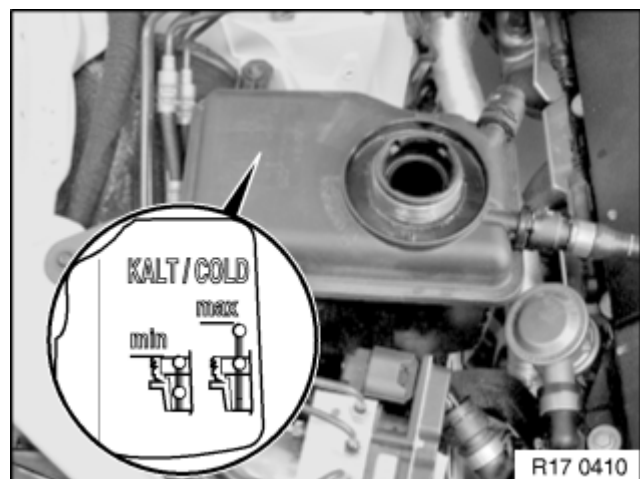

---

The engine must be cooled down before the coolant level is checked. Coolant temperature must not exceed 30°C. If ambient temperature is above 30°C, allow engine to cool down to ambient temperature at least.

Check coolant level and adjust to MAX.

Before filling:

- Turn on ignition.
- Set blower to low level.
- Set heating controller to maximum temperature.

This ensures that the heater valves are fully opened and the auxiliary water pump starts.

## WARNING!!!

Note: Do not fill coolant expansion tank over MAX level as overfilling will cause the coolant to overflow and the auxiliary water pump must deliver coolant in order to ensure fully venting!

## Cooling Fans

The heat is carried away from the engine by the coolant and then it is transferred on to the radiator fins. The cooling fans job is to force air through these fins and extract the collected heat from the radiator. In early vehicles this fan was driven by the engine, current fans are all electric in efforts to enhance fuel economy and power savings and overall efficiency.

The initial constantly driven and engine-speed dependent fans were followed by fans with a viscous coupling. This involves an engine-driven primary side which imparts drive by hydraulic friction with a transmission ratio determined by engine speed to a secondary side connected to the fan. By means of the controllable oil pressure inside the coupling, the fan speed can be varied from an idling speed to a maximum speed virtually equivalent to the primary-side drive speed.

Control is effected by virtue of a purely temperature-dependent self regulating coupling which infinitely varies its speed of rotation by controlling the volume of silicon oil in the chamber using a bi-metallic strip, a switch pin and a valve lever. The control variable is the post-radiator air temperature and, therefore, indirectly the temperature of the coolant.

The viscous fan coupling was subsequently replaced by the electric fan, which initially was only used as an auxiliary fan on vehicles with air conditioning (which at that time was an option). Those electric fans could initially be operated at multiple speeds and different power ratings were used according to country of destination (hot or cold climate). With the arrival of the electric fan, compact radiator modules were developed and are now found on all modern vehicles.

## E90 Radiator Module

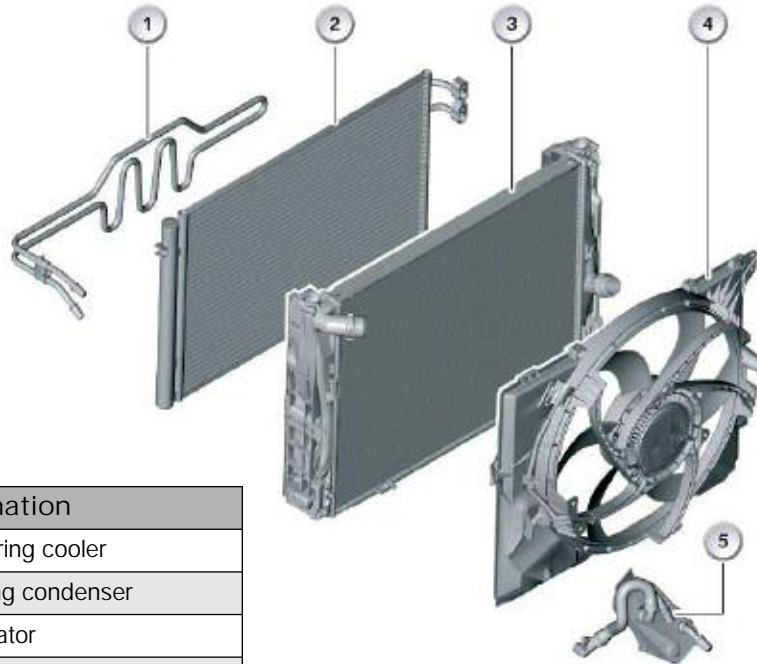

| Index | Explanation                         |
|-------|-------------------------------------|
| 1     | Power steering cooler               |
| 2     | Air conditioning condenser          |
| 3     | Radiator                            |
| 4     | Electric fan with fan cowl          |
| 5     | Transmission oil cooler (Auto only) |

Radiator modules are assembly units that consist of a number of cooling-system and air conditioning components.

### Auxiliary Fan Circuit (Early Models)

The condenser on BMW A/C systems is equipped with an auxiliary fan that provides additional air flow through the radiator and condenser, when needed.

The auxiliary fan is used to cool the outer surface of the condenser and consequently the hot gaseous refrigerant that flows through it. As the refrigerant cools, it condenses into liquid state as the heat from the passenger compartment is removed.

The engine management computer communicates with the fan control module which governs the auxiliary fan operation.

The fan is activated based on the following conditions:

- The radiator outlet temperature exceeds a preset temperature.
- The refrigerant pressures reach a predetermined crucial point.
- Vehicle speed.
- Battery voltage level.

## Coolant Pump (Mechanical)

Mechanical coolant pumps have undergone a continual process of improvement and refinement as a result of which the 3rd generation is now in use.

The design of the third-generation mechanical coolant pumps has largely overcome their leakage and lubrication difficulties as well as enhanced their housing rigidity.

This coolant pump has a "leakage retention system" Under normal conditions the coolant that escapes past the pump shaft collects in it and evaporates through a hole in the leakage chamber. If the shaft seal fails, the leakage chamber fills up completely with coolant.

Coolant escaping from the leakage chamber vent is thus an indication of shaft seal failure.

In the past, perfectly functioning coolant pumps were often replaced because the shaft-seal leakage necessary for proper operation of the coolant pump left evaporation residues on the outside of the pump housing.

The "leakage retention system" now ensures undetectable evaporation of the intended leakage so that visual inspection of the pump in the course of a service does not result in incorrect diagnosis of coolant pump failure. At the same time, the introduction of the leakage chamber also significantly increased the rigidity of the coolant pump housing.

| Index | Explanation          |
|-------|----------------------|
| 1     | Hub, for belt pulley |
| 2     | Pump shaft seal      |
| 3     | Pump impeller        |

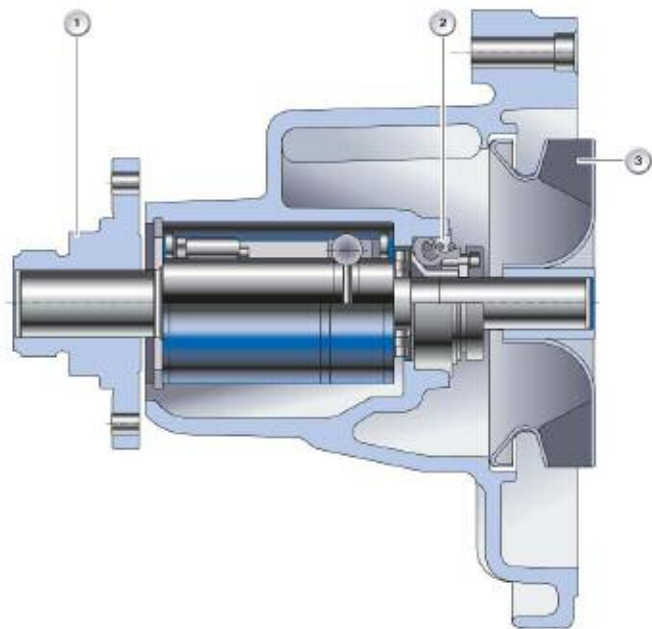

Third Generation Design

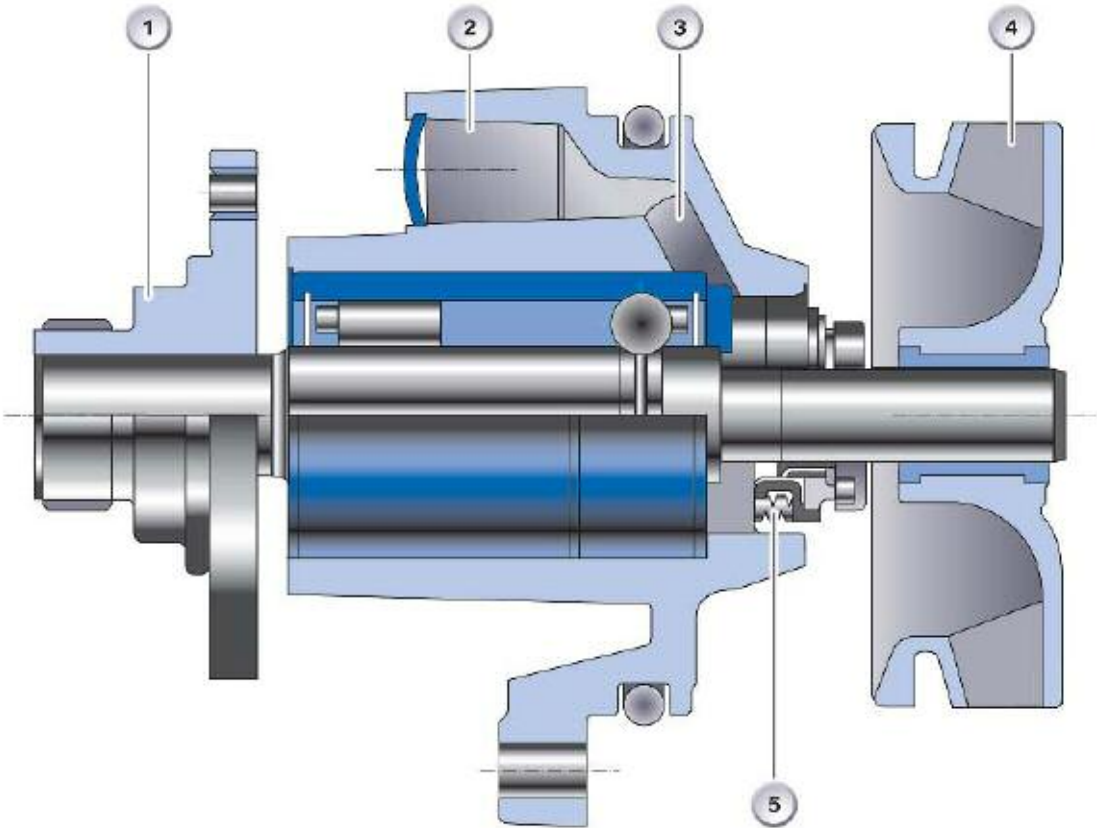

| Index | Explanation                         | Index | Explanation |
|-------|-------------------------------------|-------|-------------|
| 1     | Hub, for belt pulley                | 4     | Impeller    |
| 2     | Leakage/evaporation chamber         | 5     | Shaft seal  |
| 3     | Drain port for leakage/evap chamber |       |             |

---

## Coolant Pump (Electric)

The implementation of thermal management system on the N52 engine required that the active components of the cooling system such as pump, thermostat and fan would be electrically controllable. Electrically controllable data-map thermostats and electric fans were already established components of engine cooling systems. Thus an electric coolant pump was also developed which would reliably ensure the coolant flow demanded by the thermal management system independently of engine speed.

The electric coolant pump had to meet demanding requirements in terms of:

- Exceptional reliability
- Small dimensions
- Low power consumption (approx. 200 W)
- Controlled leakage
- Delivery of minimal volumetric flow rates
- Compatibility with high ambient temperatures

The electric coolant pump used is a wet-rotor design with an electronic motor with integrated electronics mounted on the rear of the pump.

The pump's integrated electronic circuitry has two fundamental tasks:

- To condition and connect the electric current for the motor to operate, and with it the pump.
- To regulate the coolant flow as demanded by the engine management by modulating the pump speed and to feed back information to the engine management.



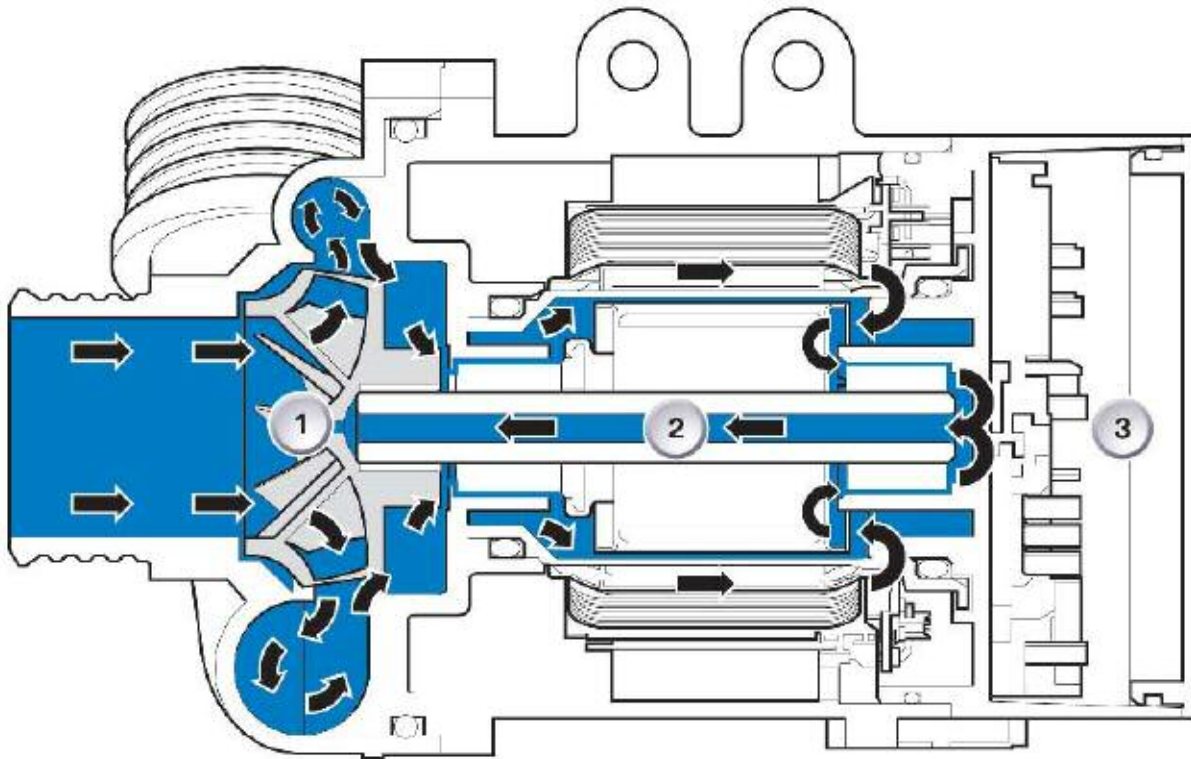

| Index | Explanation           | Index | Explanation       |
|-------|-----------------------|-------|-------------------|
| 1     | Pump impeller section | 3     | Electronic module |
| 2     | Sealed motor          |       |                   |

The modular design of the electric coolant pump (see illustration) makes it an exceptionally compact and light-weight unit which is substantially more efficient than conventional mechanical pumps.



Note: The pump should only be stored full of coolant and upright on its base.

---

## Electric Pump System Bleeding Procedure

Due to this coolant pump, a special filling and bleeding procedure must be implemented for servicing (see current repair instructions):

Fill coolant expansion vessel to bottom of filler neck with specified coolant.

Replace cap on coolant expansion vessel.

Do not remove cap from coolant expansion vessel during the bleeding sequence.

1. Connect battery charger.
2. Switch on ignition.
3. Set heater to maximum temperature (set to "Automatic"), turn fan to lowest setting.
4. Depress accelerator to maximum for 10 seconds. The engine must not be started.
5. The bleeding sequence has been started by depressing the accelerator and takes about 12 minutes. (The electric coolant pump has been activated and switches off automatically after about 12 minutes.)
6. Afterwards, fill coolant expansion tank to 250 ml above "Max".  
(Observe service instructions specific to vehicle.)
7. Check cooling system for leaks.
8. If the bleeding sequence has to be repeated (e.g. if there are leaks in the cooling system), allow DME to reset completely (remove key from ignition for about 3 minutes), then repeat procedure from step 3.



## Conventional Thermostat

The control of engine temperature by the conventional thermostat is performed purely on the basis of coolant temperature. That method of control can be divided into the following three operating phases:

- Thermostat closed: the coolant circulates only inside the engine and the cooling part of the system is closed off.
- Thermostat fully open: the total volume of coolant flows through the radiator thus utilizing the maximum cooling capacity.
- Thermostat partially open: a thermostat in which the wax element responds to the temperature of the coolant flowing over it divides the coolant flow between the radiator and a "radiator bypass". In that way, cooling can be largely prevented at very low coolant temperatures.

## Data-map Thermostat

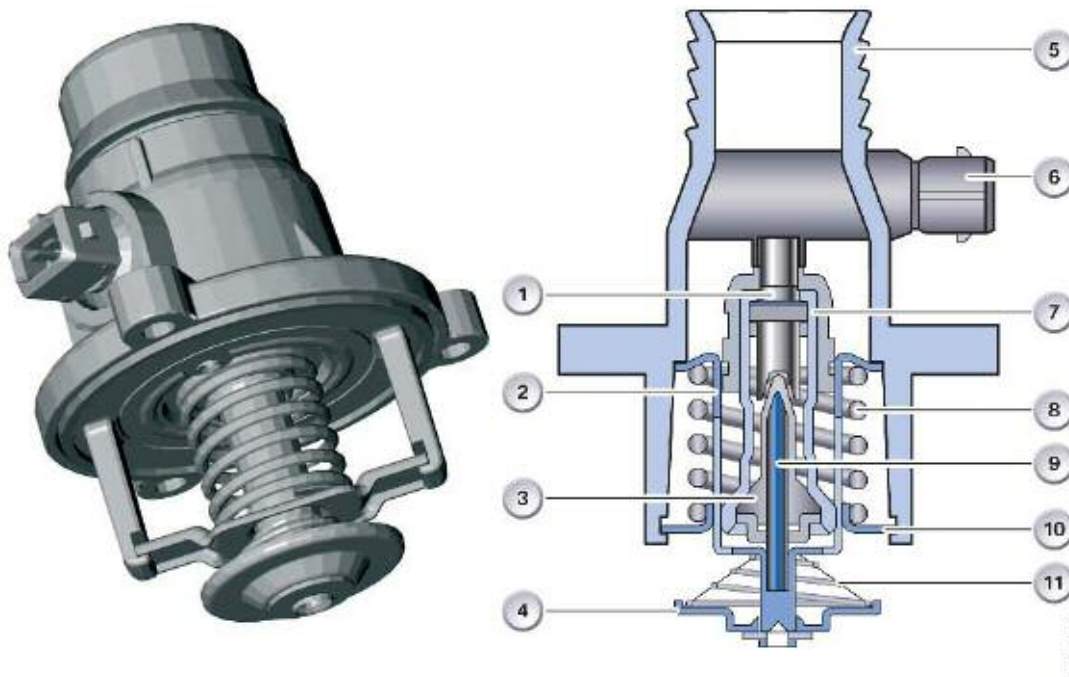

| Index | Explanation      | Index | Explanation      |
|-------|------------------|-------|------------------|
| 1     | Heating resistor | 7     | Element housing  |
| 2     | Main valve       | 8     | Main spring      |
| 3     | Elastomer insert | 9     | Operating piston |
| 4     | Bypass valve     | 10    | Cross brace      |
| 5     | Housing          | 11    | Bypass spring    |
| 6     | Connector        |       |                  |

## Control Principle of Datamap Thermostat

In view of the fact that an intelligent heat management system has an influence on fuel consumption, exhaust emissions, performance and comfort according to engine temperature, this data-map thermostat was developed for use with such a system. The data-map thermostat successfully integrates modern engine management electronics. That combination is achieved by placing an electrically heated resistor in the expanding element of the thermostat.

This means that the expanding element is no longer heated simply by the coolant passing over it but can also be "artificially" heated and, therefore, brought into operation at temperatures at which it would otherwise not respond.

The heating element is controlled by the engine management on the basis of a stored data map and according to the particular driving situation.

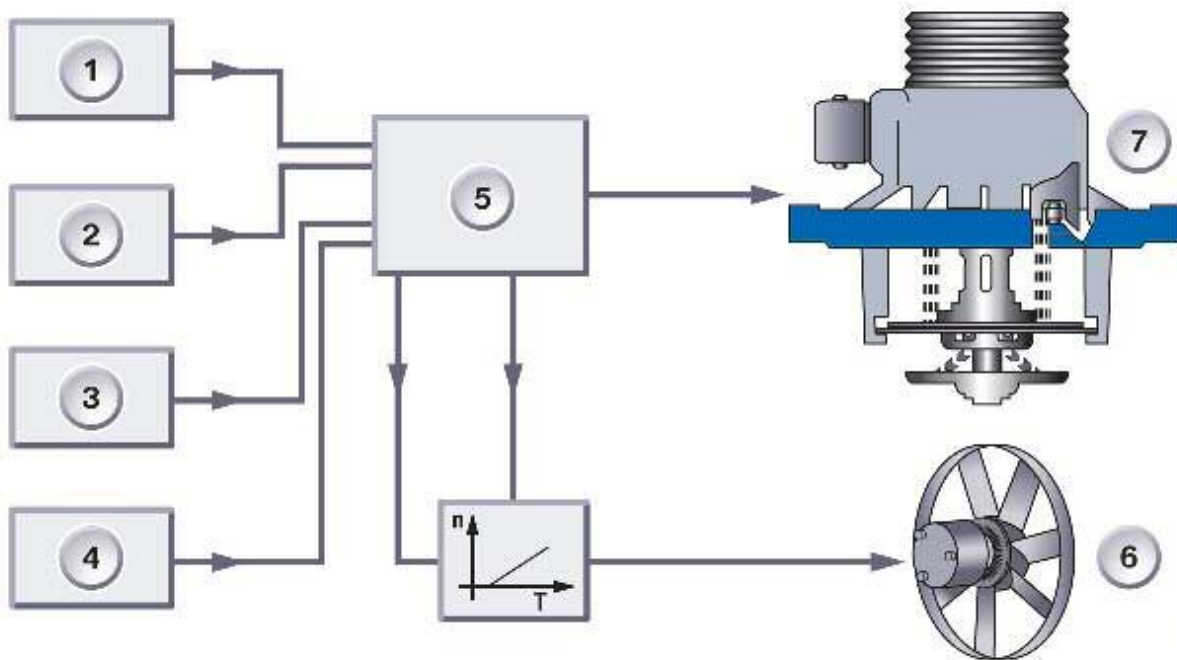

| Index | Explanation                  | Index | Explanation         |
|-------|------------------------------|-------|---------------------|
| 1     | Air-temperature data map     | 5     | Chip                |
| 2     | Load data map                | 6     | Electric fan        |
| 3     | Road-speed data map          | 7     | Data-map thermostat |
| 4     | Coolant-temperature data map |       |                     |

---

That data map was determined on the M62 engine, for example, by the following parameters:

- Engine load
- Engine speed
- Vehicle speed
- Intake-air temperature
- Coolant temperature

With such an "intelligent" control system, it is possible to use a higher coolant temperature at medium engine loads. Using higher operating temperatures at medium engine loads achieves improved combustion (assuming the engine management system is appropriately configured) which ultimately results in lower fuel consumption and exhaust emissions. At maximum engine load, on the other hand, higher operating temperatures would have disadvantages (e.g. retarding of ignition due to pinking tendency). Therefore, the data-map thermostat is used to deliberately reduce coolant temperatures at maximum engine load. Such data-map driven control is also dependent on an electric fan that can be operated by the engine management.

## Water Valves

The heating system utilizes hot coolant from the engine cooling system to warm air for heating the passenger compartment. The amount of coolant that flows into the heating system is controlled by an electric water valve(s).

The water valve is electrically actuated. It is located beside the brake booster. It controls coolant flow through the heater core. The valve is powered closed by an electric switch; when not powered, it springs open. The valve, when powered closed, prevents hot coolant from entering the heater core, so the air entering the passenger compartment is not heated. When power is removed, the valve springs open, so that hot coolant flows through the heater core and can warm the air entering the passenger compartment.

Water regulated Climate Control cars use pulsed water valves to control the heater core temperature. Air regulated Climate Control vehicles may still use a water valve to adjust the temperature of the heater core.

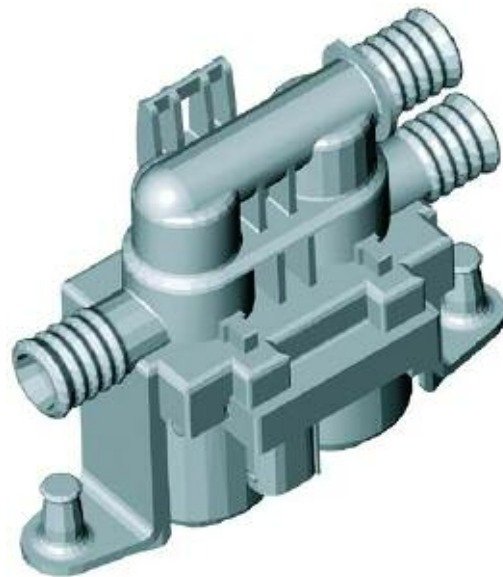

E60 Water Valve

---

## Heater Core

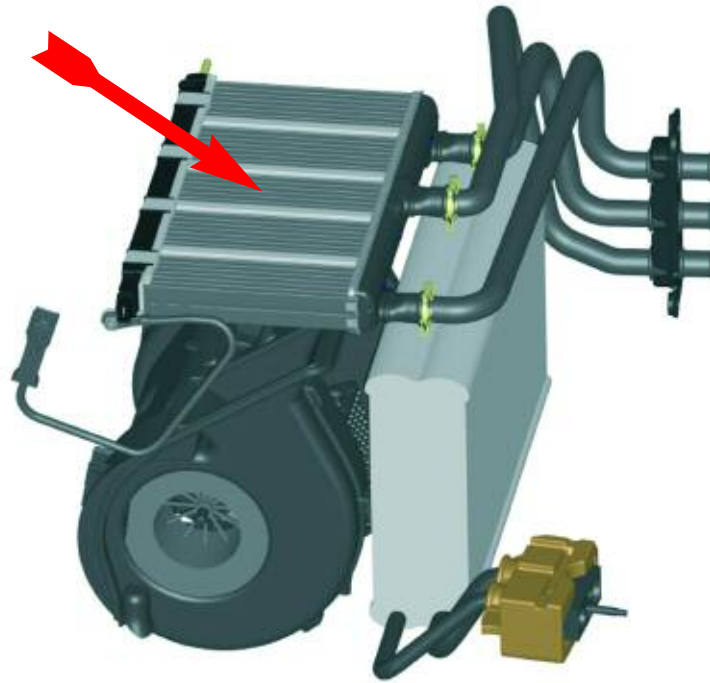

When the thermostat opens, hot coolant is flowed through the heater core. The heater core consecutively heats the air that passes through it; the hot air can then be used to warm the passenger compartment. The heater core (like the radiator) is also a “heat exchanger.” The heater core can be single core or dual core were left and right temperature outputs can be achieved individually for the use in a dual zone Climate Control system.

There are two types of temperature controls used in BMW vehicles:

- Coolant/water Regulated Temperature Control
- Air Regulated Temperature Control

In water regulated temperature control system, when the water valve is open, hot engine coolant circulates through the heater core. The temperature is controlled by varying the Duty Cycle of the water valve/valves.

In air regulated temperature control systems hot water constantly flows through the heater core and do not need to use water valve because they vary the temperature by constantly mixing in cold air from the evaporator.

In both instances the air that passes through the heater core first passes through the evaporator (if so equipped) with the intent on removing the moisture from the incoming air charge and avoiding condensation.

## Blower Fan

The blower fan is in charge of delivering the air flow to the heating/A/C System.

Although a dual squirrel-cage type blower is commonly used on most BMW (E53, E60, E63, E65 and E70 FKA), a single squirrel cage blower fan design is also installed in some other vehicles like E9X, E85, E70. Both blower designs are used to push air across the evaporator and the heater core through the plenum and out the vents.

The dual fan design is mounted in the center of the dash inside the air box. The single fan design is usually mounted on the side of the air box near the passenger seat.

Regardless of the fan design used, blower speed is controlled by resistors (in the older vehicles) or transistors that vary the amount of voltage applied to the blower, depending on the air volume control knob setting (current vehicles). In current heating and A/C systems, the blower speed is controlled electronically through the use of an output stage controller as are the engine/auxiliary cooling fans. Whenever the A/C is switched on, the fan runs at speed "1" or higher. Without the fan working, the evaporator could ice up, as humid air comes in contact with the fins.

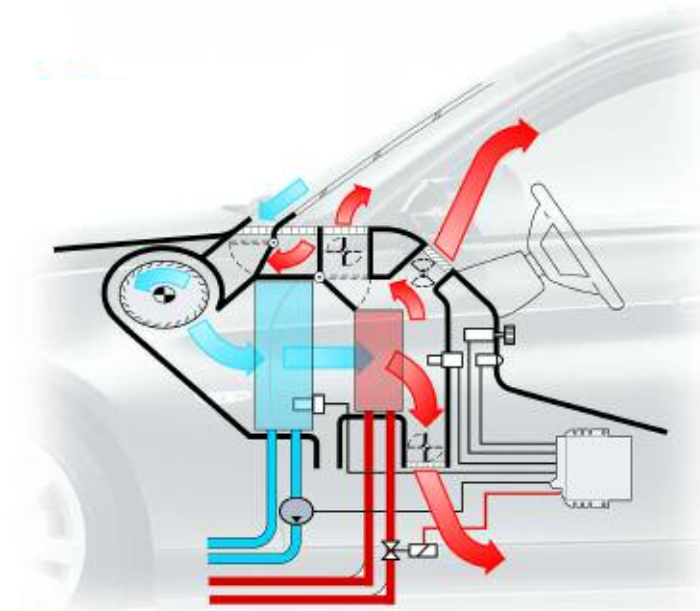



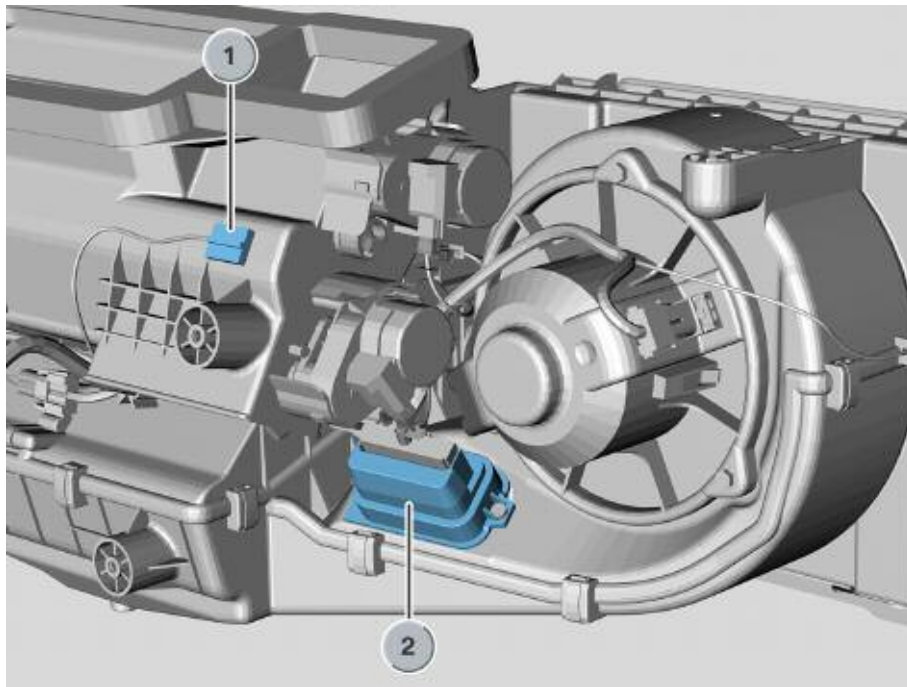

E85 Blower/final Stage Location

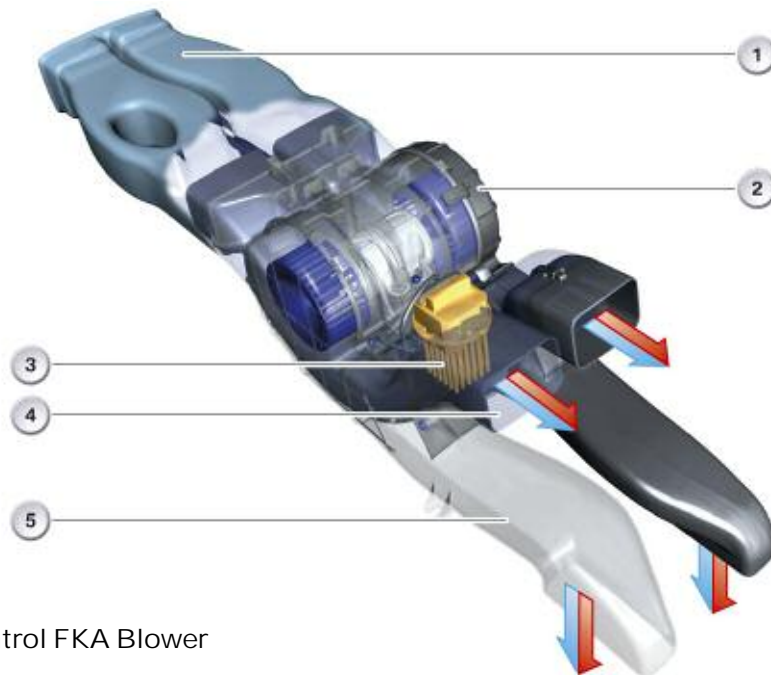

E70 Rear Climate Control FKA Blower

| Index | Explanation                          | Index | Explanation   |
|-------|--------------------------------------|-------|---|
| 1     | Left/right rear ventilation air duct | 4     | Center left/right rear ventilation outlet air ducts |
| 2     | FKA rear air conditioning blower     | 5     | Left/right B-pillar ventilation air duct            |
| 3     | FKA blower final stage               |       |   |

## Blower Control

The blower motor is actuated by the blower output stage depending on this variable control signal. The line connections from the IHKA to the final stage are monitored by the IHKA.

The blower and the output stage can be replaced separately. See appropriate workshop systems documentation. The motor voltage is limited to 12.5V by the software. If an overload is detected at the output stage output or temperature protection is activated, the engine output is reduced.

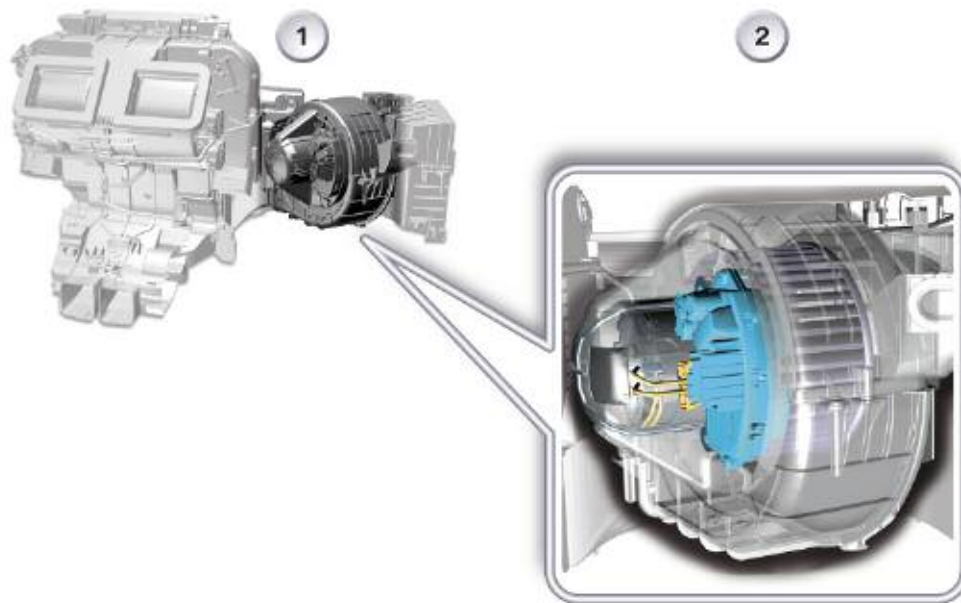

## E70 Output Stage

| Index | Explanation         |
|-------|---------------------|
| 1     | IHKA blower housing |
| 2     | blower output stage |