

---

# Table of Contents

## Climate Control Components

Subject	Page
Control Modules	4
Climate Control Panel/Module	4
Climate Control Panel/Module (E90 IHKA)	5
Digital Motor Electronics (DME) Control Module	5
Junction Box (JB)	6
Roof Control Panel (FZD)	7
Car Access System (CAS)	7
Car Communication Computer (CCC)	7
Central Information Display	7
Center Console Switch Cluster (SZM)	8
Input Sensors	9
Interior Temperature Sensor	9
AUC Sensor	10
AUC Sensor Location	10
E70 AUC Sensor	12
Solar Sensor	13
Condensation Sensor	14
Rain/Driving Light Solar Sensor	16
Mist Sensor via FZD (E70)	17
Outlet Temperature Sensor	18
Front Center Ventilation Temperature Sensor(s)	19
Refrigerant Pressure Sensor	20
Pressure Sensor via Junction Box (E70)	21
Evaporator Temperature Sensor	22
Heater Core Temperature Sensors	24
Ambient Temperature Sensor	25
Output Devices	26
Compressor Control Methods	27
SIGNAL KO:	28
SIGNAL KO-REL:	29
Compressor Control Valves	30
Electronic Control Valve at Low Loads	31
Electronic Control Valve at High Loads	31
Control Range of the Compressor	34

---

Subject	Page
Blower Motor/Final Stage .....	35
Water Valve .....	36
Water Valve (Air Temperature Control) .....	37
Auxiliary Water Pumps .....	37
Electric Water Pumps .....	38
Map Thermostat .....	39
Auxiliary Fan Control (from 99 MY) .....	40
Stepper Motors for Air Flap Operation .....	41
Conventional Stepper Motors .....	42
"Smart" Stepper Motors .....	42
E65 Stepper Motors .....	44
E60 Stepper Motors .....	45
E9X Stepper Motors .....	46
E70 Stepper Motors .....	50
Replacement of a Flap Motor .....	52
PTC Heating Elements .....	55
FKA Control Unit .....	55
E70 Third Row Heating and Ventilation PCT Heater .....	57

---

# Climate Control Components

Model: All

Production: All

# OBJECTIVES

After completion of this module you will be able to:

- Identify and locate all the different inputs and outputs of BMW climate control systems.
- Understand the operation of the inputs and outputs of BMW climate control systems.
- Describe the difference between IHKA, IHKS and IHKR systems.
- Understand how the temperature is regulated in all BMW climate Control Systems.

# Control Modules

## Climate Control Panel/Module

The control module for the climate control system comes in numerous configurations. Starting with the E38, the climate control module was integrated with the control panel. The control panel/ module is responsible for receiving and processing input information and controlling or signalling various outputs for climate control functions.

The control panel/module receives the following input information:

- Power supply and ground
  - KL31, KL30 and KL15. KL50 is used for the unloader input to shut off consumers such as the blower motor.
- Command input from driver
  - This includes desired temperatures, front and rear defrost, air distribution requests, blower speed, "snowflake button", recirculation and auto operation. Also there in the "stratified" air input for air blending at the center face vent.
- Temperature inputs
  - The system needs environmental information from various temperature sensors including heater core , ambient temp, fact vent and also receives feedback information from the interior temperature sensor to determine the temperature regulation needed.
- Road speed input
  - This is for fresh air flap operation for "Ram Air" pressure compensation.
- Pressure sensor input
  - For compressor operation and auxiliary fan control.
- Engine speed
  - The RPM information is used for auxiliary water pump/water valve operation on some models.

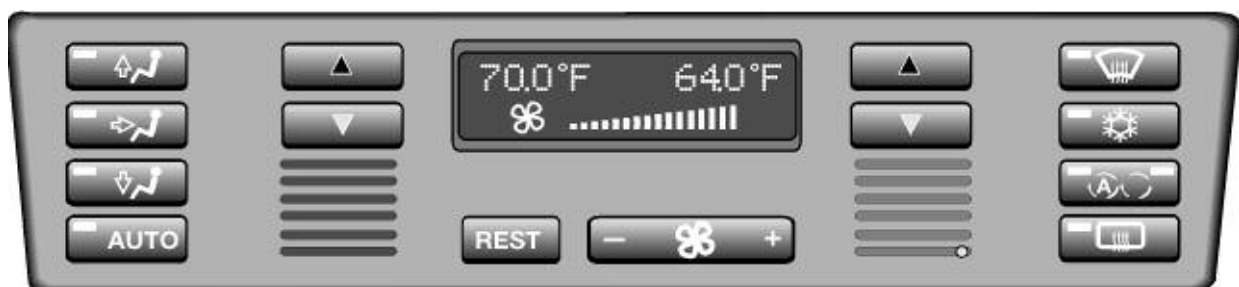

E39 IHKA control panel/module

---

## Climate Control Panel/Module (E90 IHKA)

The control and operating module is the control center of the heating and air conditioning system. It is the point where all the necessary sensor data is processed and the required settings can be entered.

Since the E90 a new feature of the control module is that it no longer directly controls all functions and components like in other models but rather makes use of other control modules for this purpose (distributed functions).

The E90 IHKA panel is directly responsible for the following:

- SZM switch input
- Solar sensor input
- Receives the rear stratification knob (rheostat) signal.
- Receives ventilation, footwell, and evaporator temperature sensor signals.
- Condensation sensor signal via the K-CAN.

The signal path is: Condensation sensor => FZD => K-CAN => IHKA



E90 IHKA control panel/module

## Digital Motor Electronics (DME) Control Module

The DME control unit performs the following functions:

- Actuates the Engine cooling fan for cooling of the condenser.
- Interfaces with the IHKA control unit via the bus network for the compressor release signal.
- Interfaces with the IHKA control unit for operation of the engine's electric water pump for the residual heat feature.

---

## Junction Box (JB)

The junction box is extremely important to the IHKA system. It is responsible for the following functions:

- Output signal for seat heating.

The signal path is: SZM => ribbon cable => IHKA => K-CAN=> JBE => SHM/SMFA

- Rear window defogger.

The signal path is: IHKA => K-CAN => JBE (relay) => Rear window defogger filters/grid

- Blower motor operating voltage.

- Refrigerant control valve (in compressor).

The signal path is: IHKA => K-CAN => JBE => Operating voltage for valve

- Gateway to the PT-CAN for bi-directional communication between the IHKA and DME.

The signal path is: IHKA <=> K-CAN <=> JBE <=> PT-CAN <=> DME

- Receives the rear stratification knob (rheostat) signal.

- Receives refrigerant pressure sensor signal.

The signal path is: Pressure sensor => JBE => K-CAN => IHKA

- Receives AUC sensor signal.

The signal path is: AUC sensor => JBE => K-CAN => IHKA

- Splice point for the ambient air temperature sensor.

The signal path is: Ambient air temperature sensor => hardwire =>through JB => IKE

---

## Roof Control Panel (FZD)

The roof control panel is used to relay the condensation sensor signal to the IHKA. It takes the signal from the condensation sensor and places it on the K-CAN.

## Car Access System (CAS)

The CAS assigns a personal identification code to every remote control. The CAS transfers the personal identification code to the IHKA control unit via the K-CAN.

The ID code "Key-based settings" (Key Memory) are stored in the IHKA control unit.

When the vehicle is unlocked, the remote control unit used is recognized. The settings stored for this unit are called up and executed. While entering the sleep mode (run-down period), the current settings are stored for the remote control unit in use at that time.

## Car Communication Computer (CCC)

If the vehicle is equipped with a navigation system, the signals from the controller for selecting the menus and sub-menu are processed in the CCC.

To actuate the CID (Central Information Display), the red-green-blue signals from the graphics processor are converted into Low Voltage Differential Signalling (LVDS) digital signals.

## Central Information Display

The following control and display functions are selected and activated with the controller in the CID (Central Information Display):

- Air distribution setting - The defrost flaps, ventilation flaps and footwell flaps can be individually set in the air distribution submenu.
- Automatic mode - The intensity of the IHKA can be set in the automatic mode submenu. In other words, the automatic influence of the climate conditions outside the vehicle on the air volume and the opening angle of the flaps can be set to one of three different settings (low, medium, high).

---

## Center Console Switch Cluster (SZM)

The center console switch cluster (SZM) is connected by means of a 14-wire ribbon cable directly to the IHKA control module. The commands from the SZM are then transmitted via K-CAN to the corresponding systems.

The A/C control and operating unit is also responsible for activation of the LEDs for function and backlighting.



E90 IHKA Center Console Switch Cluster



# Input Sensors

IHKA system performance relies on a network of sensors that input information to the controller in order to compensate and adjust all the variables that are involved in the control of the climate in the vehicles passenger compartment. These sensors vary depending on equipment options but are generally the following:

- Interior temperature sensor
- AUC sensor
- Solar sensor
- Condensation sensor
- Outlet temperature sensor
- Refrigerant high/low pressure sensor
- Evaporator temperature sensor
- Heater core temperature sensors left/ right
- Ambient outside temperature

## Interior Temperature Sensor

The interior temperature sensor is a NTC type thermistor, typically mounted in the IHKA panel. To promote adequate air flow across the sensing element a small puller type fan is used. Fan and sensor work together provide an interior cabin temperature input to the IHKA control module.



E70 Interior Temperature Sensor

---

## AUC Sensor

The AUC sensor, originally located in the lower right corner of the fan shroud, samples ambient air that has entered the engine compartment. The sensor contains a gas sensor, which measures the level of oxidizable gases in air. These include hydrocarbons, NO<sub>x</sub>, SO<sub>x</sub> and CO. The AUC sensor sends a voltage signal to the control panel/module according to the concentration of these pollutants. If a high level of pollutants is detected, the control panel/module activates the recirculating air mode as follows:

- In heating mode, recirculating air is used for a maximum of 3 minutes.
- In cooling mode, recirculating air is used for a maximum of 10 minutes.

If the level of oxidizable gases drops to an acceptable point before the time limit is reached, the IHKA system switches back to fresh air intake. If air quality has not improved at the end of the time limit, the system switches to fresh air briefly and then back to recirculating mode for another 3 or 10 minute period.

Note: Operating strategies of the AUC sensor vary from model to model.

## AUC Sensor Location



E92 AUC Sensor Location

Note: On recent vehicles the AUC sensor has been relocated closer to the fresh air intake drills of the IHKA system.

---

The IHKA control module monitors the change in the voltage signal as these gasses influence the sensor. The second circuit shown is a heating circuit which enhances the sensor's reaction time. When starting the vehicle, fresh air is always supplied due to the AUC sensor heat-up time.

Pressing the button again activates the recirculating air mode.

Pressing the button once again returns to fresh air mode.

Recirculating air mode and AUC mode are indicated by green function lights (LEDs) on the control panel.



The AUC/recirculating air function also features "forced ventilation with fresh air," the activation and duration of which depends on whether the system is in A/C mode (compressor active). The fresh air is already dehumidified if the A/C compressor is ON, therefore, the duration of recirculating air mode is longer.

The IHKA measures air quality by analyzing the AUC sensor signal. The AUC-2 sensor provides a PWM signal corresponding to the noxious-gas content. The sensor is provided 5V to activate the heating circuit (approx. 500 - 800 mW).

Relative humidity inside the car can increase during a recirculated air phase, because the proportion of fresh air is low. This can cause the windows to fog, therefore recirculation in the AUC function is limited.

---

## E70 AUC Sensor

The AUC sensor is an air quality sensor and is used to control the ventilation in the vehicle interior (fresh air, recirculated air) in combination with the IHKA control unit, depending on how much traffic-specific pollutant the fresh air contains. This increases the well-being of the occupants and reduces the amount of pollutant to which the occupants are subjected.

The AUC sensor is a fully integrated system consisting of the sensor element, the signal processing system and a digital interface.

A metal oxide sensor is used, which is extremely sensitive to different odors and exhaust emissions that typically occur in traffic.

The signal processing unit calculates the air quality level by continuously monitoring the quality of the fresh air. The IHKA control unit is notified of this via the junction box interface.

Depending on other parameters (ambient temperature, humidity, road speed etc.), the IHKA control unit decides whether to allow the recirculated air request from the AUC sensor (including determination of the duration thereof) or suppress it.

The AUC sensor is installed at the air filter housing in the E70.

An important task that is performed by the electronics is accurate control of the sensor operating temperature. The sensor element needs an operating temperature of approximately 300°C. The sensor detects gases that can be reduced and oxidized. The main ones are carbon monoxide CO (gasoline) and nitrous oxide NO as an indicator of soot particles from diesel vehicles.



AUC Sensor at E70 Filter Housing

---

## Solar Sensor

The solar sensor records the light intensity of the insolation to which the vehicle interior is being subjected separately for the right and left-hand sides. The influence of insolation on the temperature in the vehicle interior is compensated for in automatic mode by means of temperature specified value control intervention.

Typically located in the center of the dashboard or integrated to the rain light sensor assembly on E70. The solar sensor consists of a light sensitive diode that provides the IHKA module with inputs of sunlight intensity. The input is used as a measure of the solar heating effect on vehicle occupants. The sensor signals will influence blower output, air stratification and ventilation flap operation.

### Solar Sensor Location E60

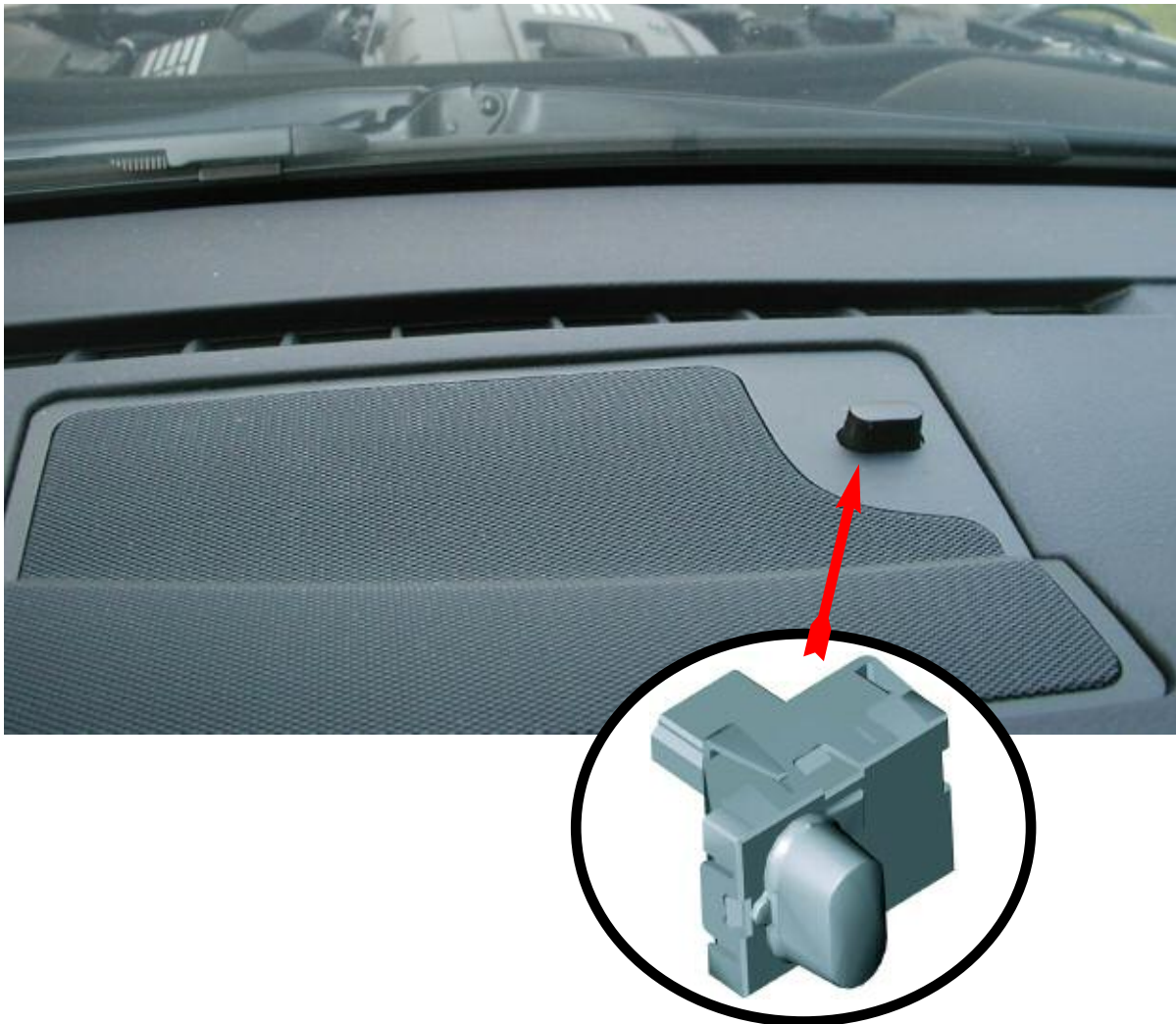

## Condensation Sensor

The condensation sensor is relatively new to BMW climate control systems. Introduced with the E60 model, this sensor varies its frequency out put in response to the presence of humidity and temperature in the windshield area. This information is sent to the IHKA control module via a digital signal with a varying frequency. The information is evaluated by the IHKA control module, which then implements a series of countermeasures to prevent windshield fogging.



Index	Explanation
1	Rain-light sensor
2	Condensation sensor

On the current E60 the condensation sensor is mounted under the rain light sensor (RLS) on the mirror base. Other names for the condensation sensor are Mist, Fogging, and Humidity sensor.

When moisture is detected by the Condensation Sensor, the following occurs:

- Defroster Flaps open further
- Fresh Air Flaps open 100%
- Blower speed is increased
- Footwell Flaps are closed
- Temperature increases
- Evap Temperature threshold goes to minimum

These measures are implemented one after another until windscreen fogging is eliminated. Further steps are initiated if one measure proves to be ineffective. After successfully eliminating windscreen fogging, the measures are gradually cancelled in steps.

The sensor is located beneath the RLS on the windshield below the cover for the base of the rear view mirror.

A special locating tool is used to install the new sensor, this tool is supplied with the replacement sensor.

The sensor is affixed to the windscreen with an adhesive. If the sensor needs to be removed from the windshield it must be replaced.

Index	Explanation
1	Sensor Electronics
2	Pin Connection
3	Moisture measuring cell
4	Well for laser adjusted resistors

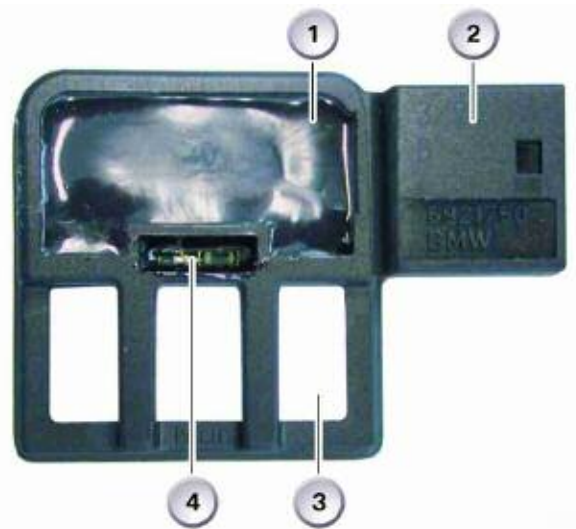

The sensor varies its frequency out put in response to the presence of humidity. On the current E90 the condensation sensor is controlled and powered by the roof module (FZD).

The sensor data are transferred via the K-CAN to the control and operating unit where they are evaluated. The IHKA control module receives all information sent from the FZD control module via the K-CAN spliced through the junction box.

Note: Similar to previous systems, the condensation sensor value is ignored unless the IHKA panel is running in the automatic mode.

---

## Rain/Driving Light Solar Sensor



E70 RLSS Rain/Driving Light Solar Sensor

The new rain/driving light solar sensor RLSS of the E70 is clipped into a retaining ring beneath the windshield mirror base cover.

The rain/driving light solar sensor separately records the insolation acting upon the vehicle occupants for the left and right halves of the vehicle. It generates two signals that are proportional to the insolation acting upon the vehicle occupants.

The temperature rise due to heat from sun radiation in the vehicle interior is compensated for in automatic mode by means of temperature specified value control intervention. The sensor signal is read in by the FZD via the LIN bus and relayed to the IHKA via the K-CAN.

The signals are used by the IHKA to regulate the left and right air volume and ventilation temperature



---

### Mist Sensor via FZD (E70)

The mist sensor BSS is directly clipped to a bracket on the rain/driving light solar sensor beneath the mirror base cover.

The sensor provides early window mist detection, even before the driver can see any. Counter measures are taken automatically at an early stage, without the need for driver intervention. Good ventilation is needed for the sensor to operate efficiently. Suitable ventilation slots have therefore been provided in the mirror base cover that provide the sensor with an adequate amount of airflow.

The sensor has to be within the range of the windshield wipers so that temperature changes caused by snow or ice on the other side of the windshield can be compensated for.

The "glass conditions" that are present in the driver's field of view must also exist at the sensor. This is the only way for conclusions to be drawn about the window mist in the driver's field of view from the mist at the sensor.

A capacitive sensor element is used for early detection of possible dew formation on the windshield or for removing mist that is present on the windshield.

The sensor is supplied with 5V by the FZD. There is a frequency signal at the sensor output. The signal, which is evaluated by a regulator, is read in by the FZD and relayed to the IHKA via the K-CAN.

#### System hardware:

- Windshield
- Condensation sensor
- FZD
- IHKA

#### Peripherals:

- Blower
- Ventilation flaps
- Compressor
- Water valve

## Outlet Temperature Sensor

Negative Temperature Sensors are installed in the air outlet vents in order to monitor air vent temperature. This is a crucial parameter in the calculation of the ideal outlet temperature with regard to the requested temperature value. Depending if the system is single, dual zone or four zone like E70, these sensors operate in the same manner and in all cases are located in the middle of the air delivery.

In the case of a four zone system the driver, front passenger and rear seat passengers may have their own individual temperature settings. This is in part possible because of the use of these individual outlet vent temperature sensors.

### E70 Rear Air Stratification Sensors and Potentiometer



Index	Explanation
1	E70 FKA rear center ventilation outlet
2	Left/right rear ventilation temperature sensors
3	Left/right rear air stratification potentiometer
4	Left/right rear ventilation manual shut-off flap

### Front Center Ventilation Temperature Sensor(s)

Depending on the equipment variant, the signal values from one or two sensors in the ventilation outlets are still used to control the temperature in the vehicle interior.

The IHKA records the separately adjustable right/left temperatures with two sensors.

The ventilation temperature sensor default value is 20°C.

### E70 Center Front Ventilation Air Vent Outlet

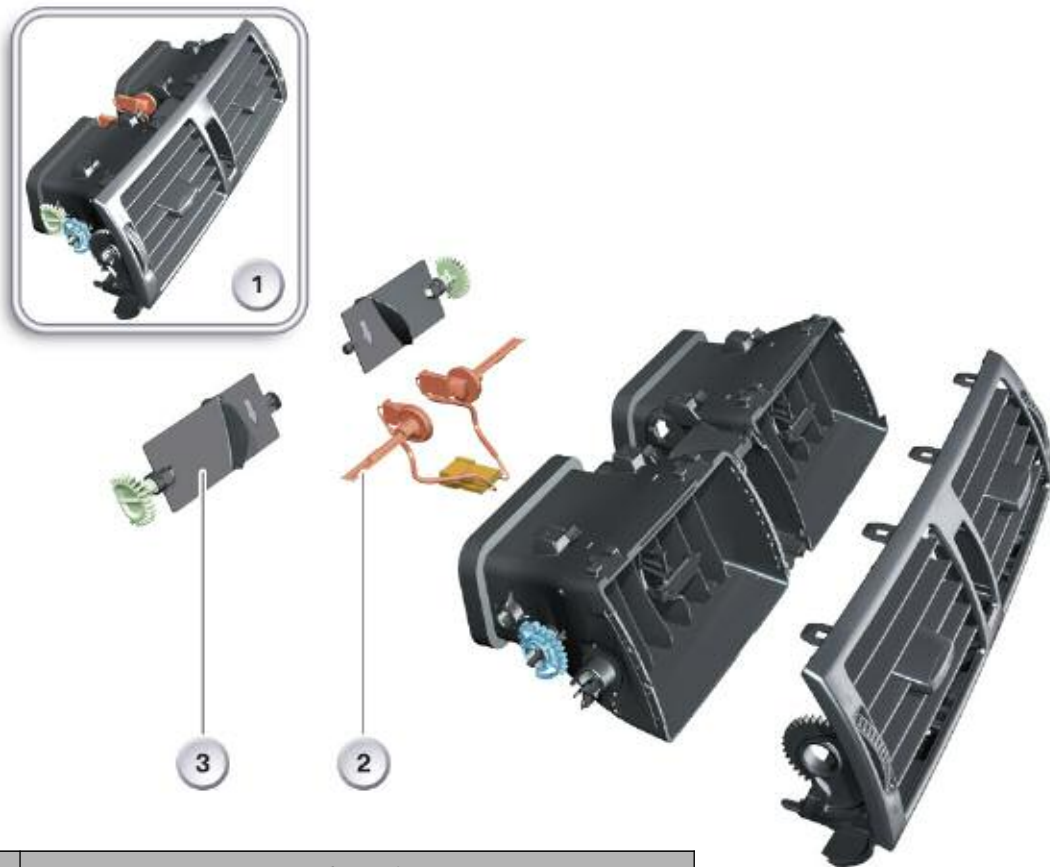

Index	Explanation
1	Center front ventilation outlet IHKA
2	Front left/right ventilation temperature sensors
3	Manual shut-off flap, front left/ right ventilation

---

## Refrigerant Pressure Sensor

The pressure sensor is mounted on the liquid reservoir and sends out a voltage signal depending on the high pressure in the air conditioning system.

This signal is transferred in the form of a telegram to the digital motor electronics (DME). In turn, the DME outputs the control voltage for the output stage of the auxiliary fan, thus activating the corresponding fan stage (speed).

Activation of the auxiliary fan is also influenced by an excessively high coolant temperature.

On vehicles equipped with a condenser module (filter dryer integrated in the condenser), the pressure sensor is installed in the high pressure line between the condenser and expansion valve.

On various automatic transmission vehicles such as the E65 and E60, the auxiliary fan is also activated by excessively high transmission fluid temperature. The higher fan stage is then generated in this case.

The sensor sends the IHKA control module an analog signal between 0.4V and 4.6V as a representation of system pressure.

The 5V supply is provided by the IHKA control module and the sensor current consumption is < 20mA. (E60)

The refrigerant pressure sensor is located in the pressure line between the condenser and the evaporator. The output of the A/C compressor is reduced by a request from the the IHKA control unit to the JBE in the event of excessively high or low refrigerant pressure. (E90)

The junction box provides power to the refrigerant pressure sensor. The data are evaluated in the junction box electronics. The evaluated data are transmitted to the IHKA control unit via the body CAN (K-CAN).

The signal path is:

Pressure sensor => JBE => K-CAN => IHKA

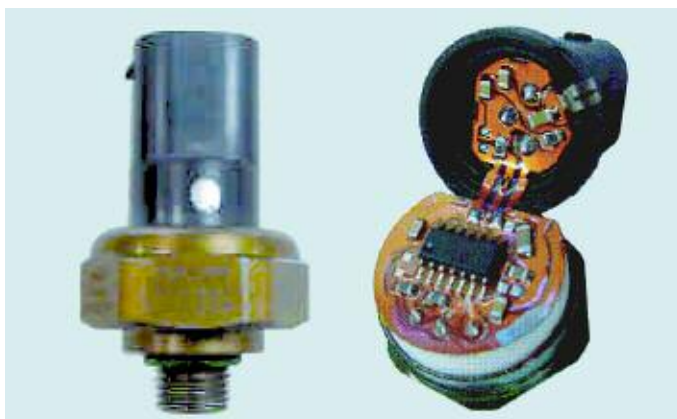

---

## Refrigerant Pressure Sensor



### Pressure Sensor via Junction Box (E70)

The refrigerant pressure input signal is a direct junction box input signal and is relayed to the IHKA via the K-CAN. The IHKA requests actuation of the auxiliary blower by the DME/ depending on the refrigerant pressure.

The IHKA determines the relevant A/C compressor load torque on the basis of the input signals from the pressure sensor and the compressor speed.

The DME control units are notified of the load torques by the IHKA and used by the DME as input variables for actuating the electric fan.

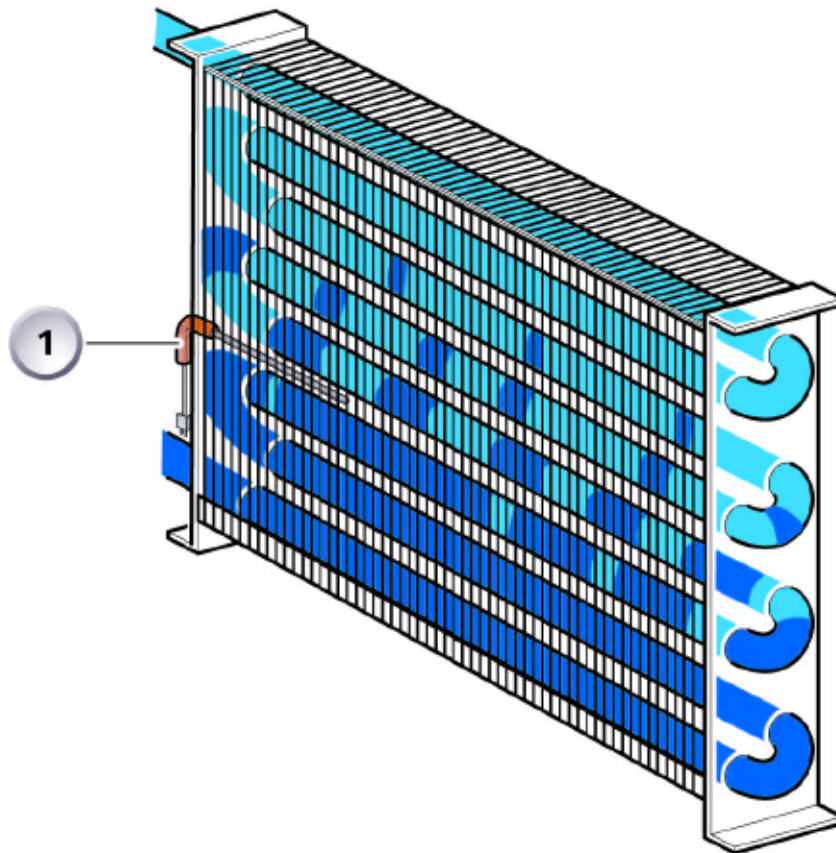

## Evaporator Temperature Sensor

The sensor is installed between the evaporator fins or arranged behind the evaporator in the flow of cold air. Depending on the type of system in the vehicle, the temperature at the evaporator is monitored as the regulator switches the electromagnetic clutch of the compressor on and off or signals the compressor control valve (clutchless compressor) as required. This prevents the evaporator fins from icing up due to frozen condensed water.

Controlled via the IHKA control unit, the sensor generally switches off the compressor at a temperature of approx. 1°C (33°F) and on again at approx. 3°C (37°F).

In connection with the output-controlled compressors with magnetic clutch, the sensor only serves as a protection function in the event that the temperature at the evaporator drops below 3°C. Consequently, the compressor remains switched on almost permanently. With the interior temperature set at comfortable levels, the compressor is generally switched off by the electromagnetic clutch only at outside temperatures below approx. 6°C (42.8°F).

In the case of output-controlled compressors without an electromagnetic clutch, if there is a threat of the evaporator icing up, the IHKA will correspondingly change the pulse-width-modulated control signal via the electric control valve in the compressor. Consequently, the compressor output is reduced in the direction of zero. Icing of the evaporator can be recognized by decreasing air volume at the air outlet vents.

---

The evaporator temperature sensor has the characteristics of an NTC resistor (negative temperature coefficient).

Resistance as a function of temperature:

Temp.	Resistance
-5°C	11.4-11.9 KΩ
0°C	8.8-9.2 KΩ
5°C	6.8-7.2 KΩ
10°C	5.3-5.6 KΩ
15°C	4.2-4.5 KΩ
20°C	3.3-3.6 KΩ
25°C	2.6-2.9 KΩ
30°C	2.1-2.3 KΩ
35°C	1.7-1.9 KΩ

The default or substitute value of the sensor in the event of a break or short-circuit is  $< 0^{\circ}\text{C}$ . This setting ensures that the air conditioning system remains switched off and icing is prevented.

New vehicles as from the E60 feature variable evaporator temperature control. Depending on the outside temperature, the evaporator temperature is set between  $1^{\circ}\text{C}$  and  $8^{\circ}\text{C}$ . The colder the outside temperature, the higher the evaporator temperature is set.



E60 Evaporator Temperature Sensor

---

## Heater Core Temperature Sensors

Heater core temperature is monitored to insure the correct desired temperature at the vents. Heater core temperature along with ambient, vent and evaporator temperatures are the main parameters utilized to calculate Y Factor. Thus we control the coolant flow through the heater core by varying the heater valve opening on a water based system.

The Air regulated System has no need for a water valve because it controls temperature by adjusting the air mixing flap.

As an added benefit we also monitor heater core temperature in other to maintain a safe range of operation and in case of over heating the heater valves can be shut off.

In IHKA the individual temperature readings are of crucial importance and necessary in other to be able to separately adjust the outlet temperature for the driver and the passenger. This calls for the installation of two heater core temperature sensors.

E60 Heater Core Temperature Sensor

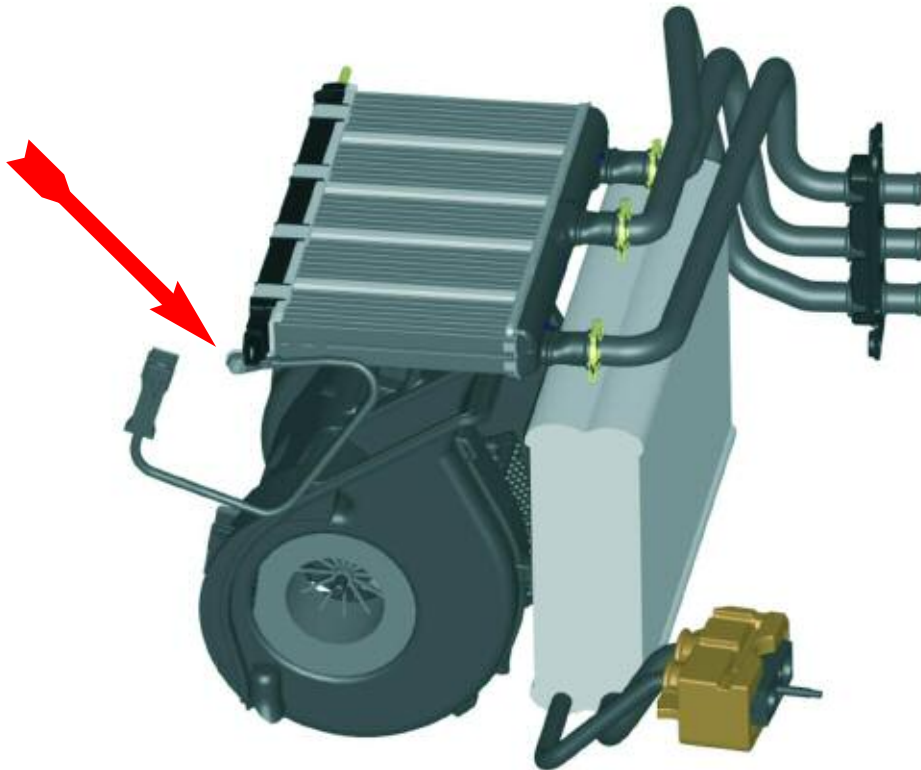



---

## Ambient Temperature Sensor

The ambient temperature sensor is similar to interior, evaporator, heater core and outlet vent sensors in their operation. An NTC negative temperature coefficient sensor as temperature goes up resistance goes down.

The temperature sensor is located at the front end of the vehicle in front of the condenser and it is responsible for reporting ambient temperatures to all systems that require the reading.

E60 Ambient Temperature Sensor



# Output Devices

Based on the feedback from the IHKA inputs, the system calculates the Y factor and reacts to the desired requested temperature and/or conditions detected to operate the following output devices to deliver optimum performance:

- Compressor clutch/Compressor control valve
- Blower motor/Final stage
- Water valves
- Auxiliary water pumps
- Electric water pump
- Auxiliary fan
- Stepper motors

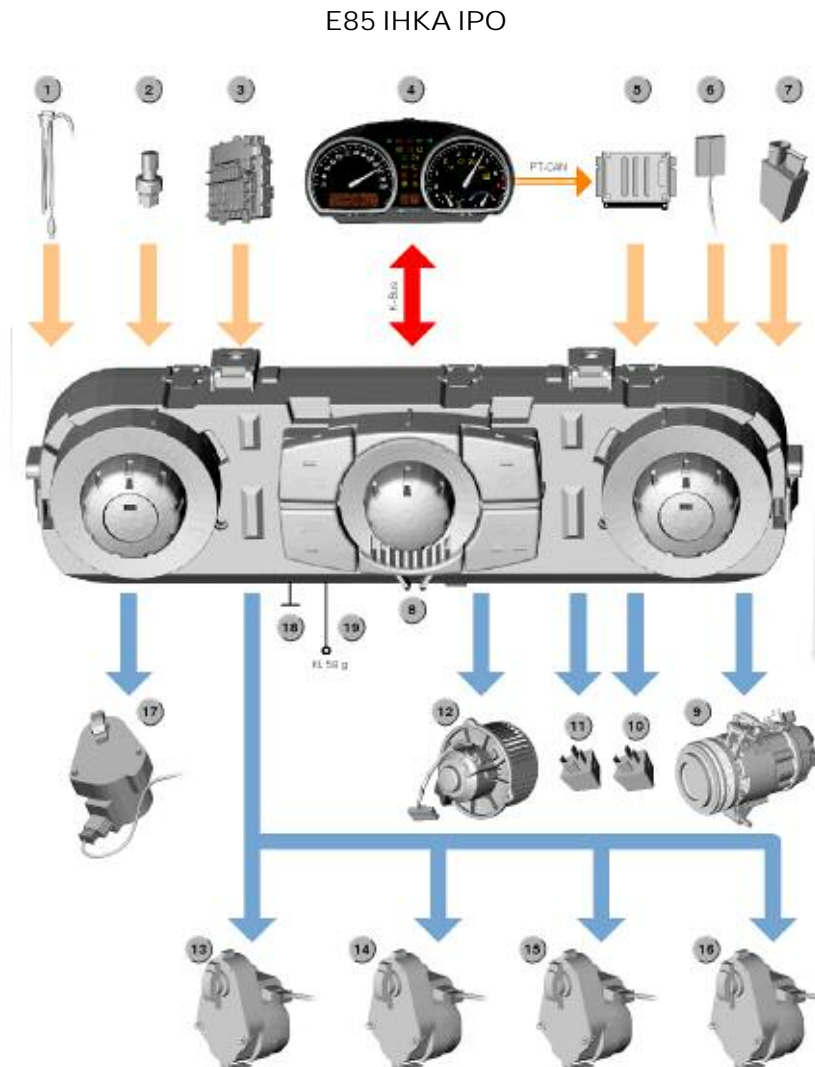

## Compressor Control Methods

The compressor control circuit varies between systems. There are three basic methods for compressor control:

- The compressor clutch coil receives power from the KL 87 terminal of a relay which is ground controlled by ECM (DME).
- The compressor clutch is powered directly by the climate control module. A final stage in the control module sends power directly to the compressor clutch. The relay and additional wiring are eliminated.
- Constantly engaged compressors are usually variable displacement units. The compressor has a swash plate that can vary the amount of compression on the refrigerant with the use of control valve.

The engine control module (ECM) and the IHKA control panel/module communicate via three direct circuits; there are no relays. The IHKA control panel/module powers the A/C compressor clutch coil directly; again, there is no relay.

E36 IHKA Compressor Control Circuit

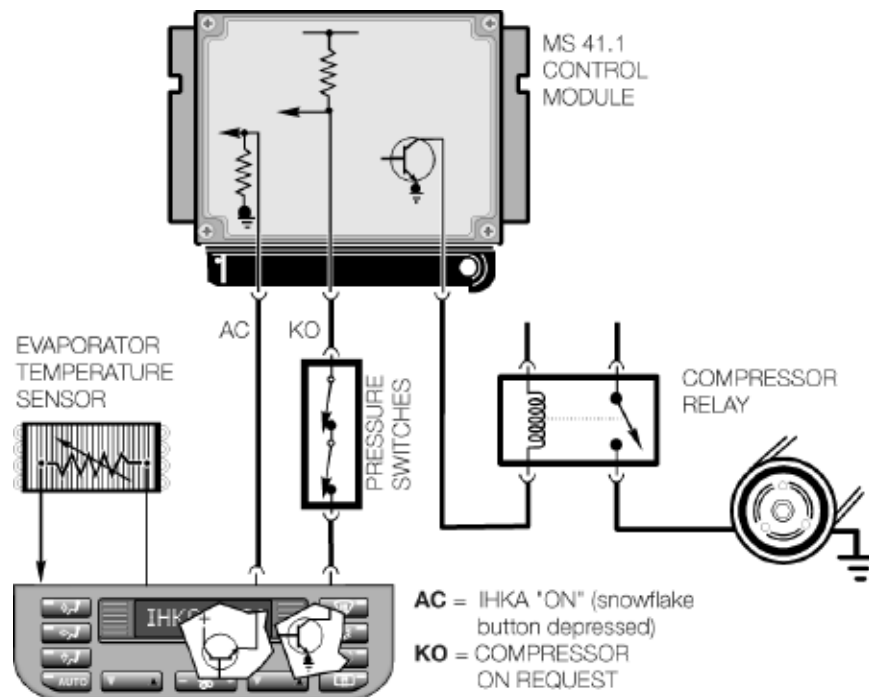

Activation of the compressor clutch is an output control function of the IHKA module. As with the E38 IHKA, activation is carried out directly through a final stage in the module (no relay required).

#### Typical IHKA Control

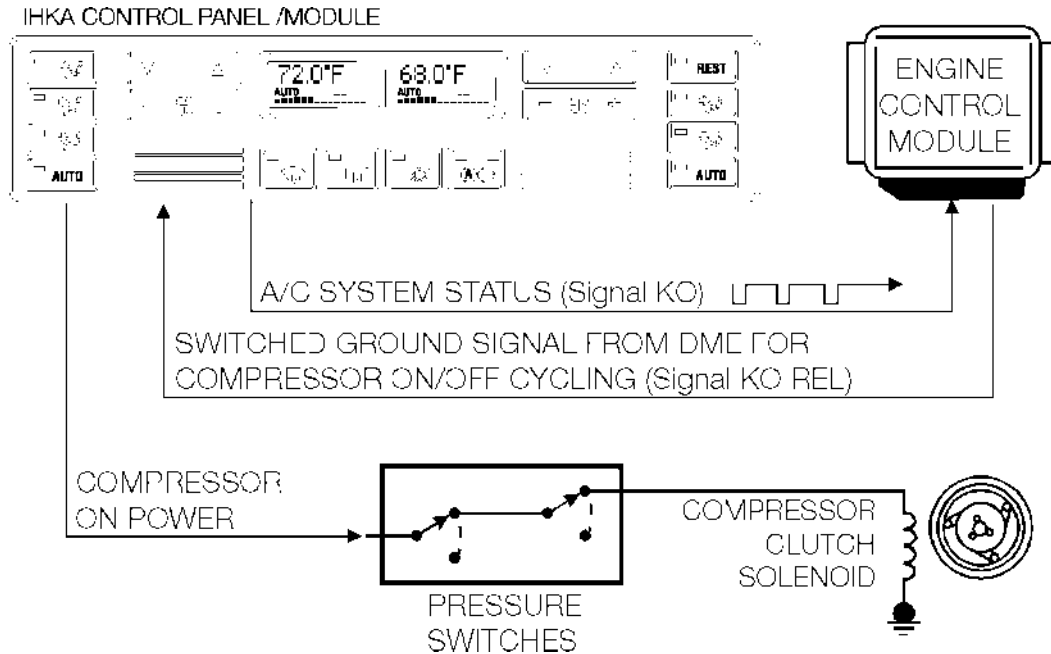

The signals KO and AC have been combined into one signal providing multiple data through a stepped increase in signal duty cycle.

#### SIGNAL KO:

- 15% Duty Cycle: IHKA is OFF.
- 30% Duty Cycle: IHKA is switched ON (Standby).
- 45% Duty Cycle: Snowflake button is pressed, the IHKA signals the engine control module to raise the idle speed in preparation of the compressor being switched on. This takes place before the IHKA energizes the compressor.

## SIGNAL KO-REL:

The engine control module signals the IHKA (Signal KO-REL) when the idle increase has taken place and the IHKA will then activate the compressor clutch, as long as all other compressor requirements are satisfied. Compressor cut off conditions include:

- Evaporator temperature below 20C.
- Coolant temperature > 117OC - causes the compressor to run in a pulsed operation.
- Coolant temperature > 120OC - the compressor clutch is deactivated until the temperature drops below 117OC.
- Full acceleration at low speeds - below 10 MPH with a full throttle input will cause the compressor to shut off for 10 seconds.

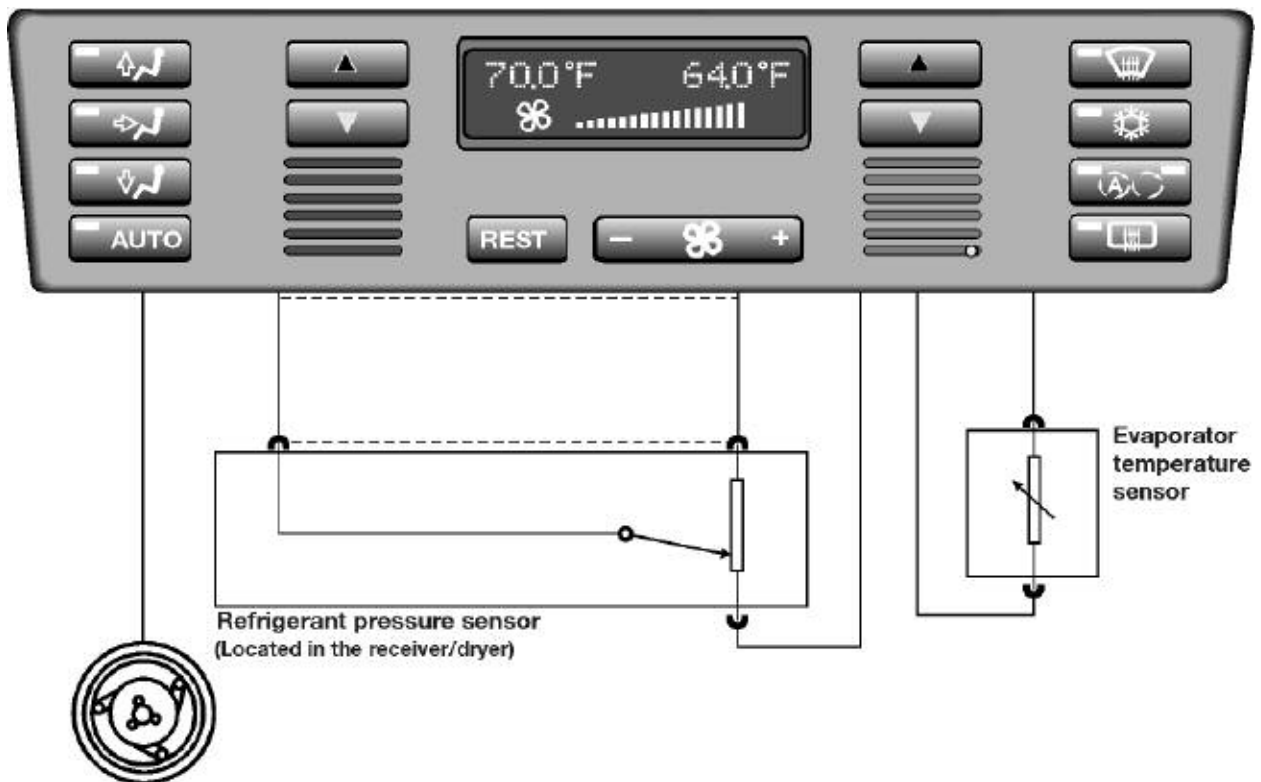

For '99 Model Year, E39 IHKA now receives a variable input from the refrigerant pressure "sensor". The sensor is mounted in the receiver/dryer.

Based on the refrigerant pressure, the pressure sensor input allows the IHKA module to determine the "start up" torque of the A/C compressor. If the pressure is too low or high the compressor will be deactivated. The IHKA also anticipates the necessary auxiliary fan speed and passes this information on to the ECM via the K-bus.

---

## Compressor Control Valves

Depending on application, the compressor may or may not use a magnetic clutch. In vehicles that use clutchless compressors they are always engaged when the engine is running. This results in constant drag on the engine which affects emissions and fuel economy. The compressor output is always variable and is controlled internally by either a mechanical control valve that operates solely on A/C pressure differential and does not need electronic signals or an electronic control valve, operated directly by signals from the IHKA control module depending on the system demand.



Mechanical (Left) Electronic (Right)



Electronic Control Valve Location

Delivery rate and pressure is produced by 5 to 7 pistons in the compressor. The piston stroke is influenced by a swash plate. The position of the swash plate is varied by the internal pressure which is controlled by the valve mounted in the rear of the compressor.

The control valve influences the force at the swash plate by changing the crankcase chamber pressure. When de-energized the electronic control valve opens and the swash plate is almost vertical and not deflected. The compressor output is approximately 0 - 2% which is required to maintain internal lubrication.

The electronic valve is controlled and powered by the junction box in most recent models but the command comes from the IHKA module.

The IHKA control module sends a pulse width modulated signal (12V, 0.85A at 400 Hz) to close the control valve. This causes the pressure in the crankcase chamber to diminish. The swash plate is deflected (angled) and the compressor output increases (variable between 2 - 100%). See Externally Controlled A/C Compressors under A/C System Components for more information.

Note: Some BMW vehicles have been switched from clutchless pulleys to magnetic clutch (E70). Magnetic Clutch compressors have been proven to increase fuel economy and lower tailpipe emissions.

---

#### Electronic Control Valve at Low Loads

When the thermal load is low, the intake pressure ( $P_s$ ) decreases, the bellow-type gaiter of the control valve expands and the control valve opens. As a result, the high pressure ( $P_d$ ) acting on the swash plate chamber causes the internal pressure ( $P_c$ ) in the swash plate chamber to rise.

The sum of the pressure in the swash plate chamber ( $P_c$ ) x 7 cylinders + force of spring A (to the left of the swash plate) + counter force of the drive plate that acts on the left side of the pistons in the seven cylinders is higher than the pressure  $P_1 - P_7$  that acts on the right side of the seven pistons.

Consequently, the lower piston moves to the right and therefore reduces the inclination angle of the swash plate. As a result, the piston stroke decreases and the compressor.

operates at minimum displacement. The spring 1 (to the left of the swash plate) moves the seven pistons to the right and thus reduces the angle of the swash plate. This spring therefore has the function of a starter spring, starting at minimum displacement volume of approx. 5% as the current from the IHKA control unit to the solenoid valve is switched off and the valve is open.

#### Electronic Control Valve at High Loads

When the thermal load is high, the IHKA control unit detects a higher temperature via the evaporator temperature sensor and activates the solenoid valve accordingly.

The valve body is shifted to the left and the valve closes. The intake pressure ( $P_s$ ) is high, the bellow-type gaiter of the control valve is compressed, also causing the valve body to be shifted to the left, closing the valve.

As a result, the high pressure ( $P_d$ ) is reduced and the pressure ( $P_c$ ) in the swash plate chamber drops to the level of the intake pressure ( $P_s$ ). The balance is achieved through an orifice (gas flow).

Consequently, the sum of the pressure in the swash plate chamber ( $P_c$ ) x 7 cylinders + force of spring 1 (to the left of the swash plate) + counter force of the drive plate that acts on the left side of the pistons in the seven cylinders is lower than the pressure  $P_1 - P_7$  that acts on the right side of the seven pistons.

Consequently, the lower piston moves to the left and therefore increases the inclination angle of the swash plate. As a result, the piston stroke is increased and the compressor runs at up to 100% output capacity.

The system detects a drop in the evaporator temperature via the evaporator temperature sensor.

The IHKA control unit now activates the solenoid valve accordingly and opens it slightly in order to reduce the pressure and therefore the angle of the swash plate.

Compressor at Low Thermal Load and Low Ambient Temperature

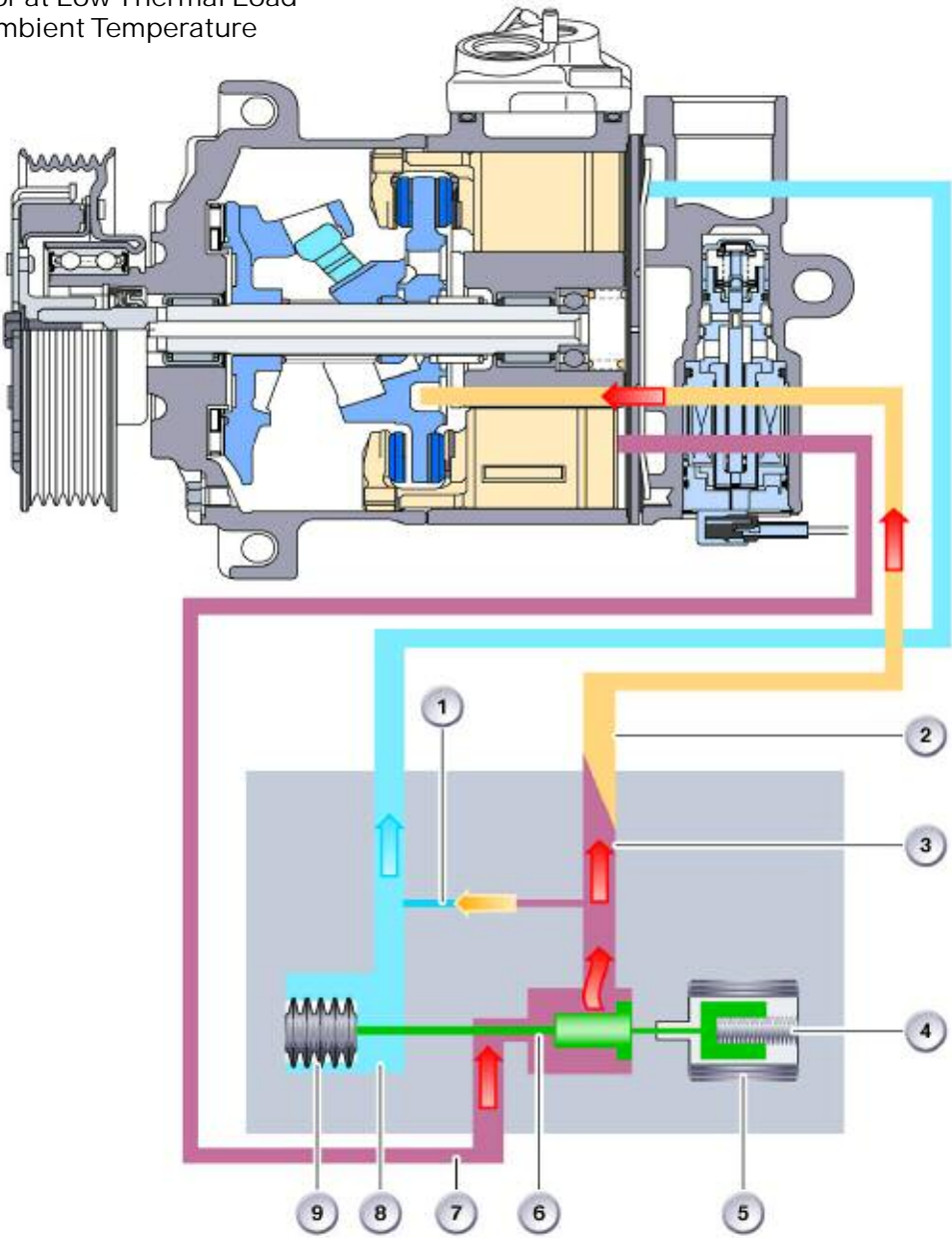

Index	Explanation	Index	Explanation
1	Orifice Between $P_c$ and $P_s$	6	Valve Push Rod
2	Crank Chamber Pressure $P_c$	7	High Pressure $P_d$
3	Gas Flow	8	Intake Pressure $P_s$
4	Spring 2	9	Gaiter With Spring1
5	Coil (Solenoid Valve)		



Compressor at High Thermal Load and High Ambient Temperature

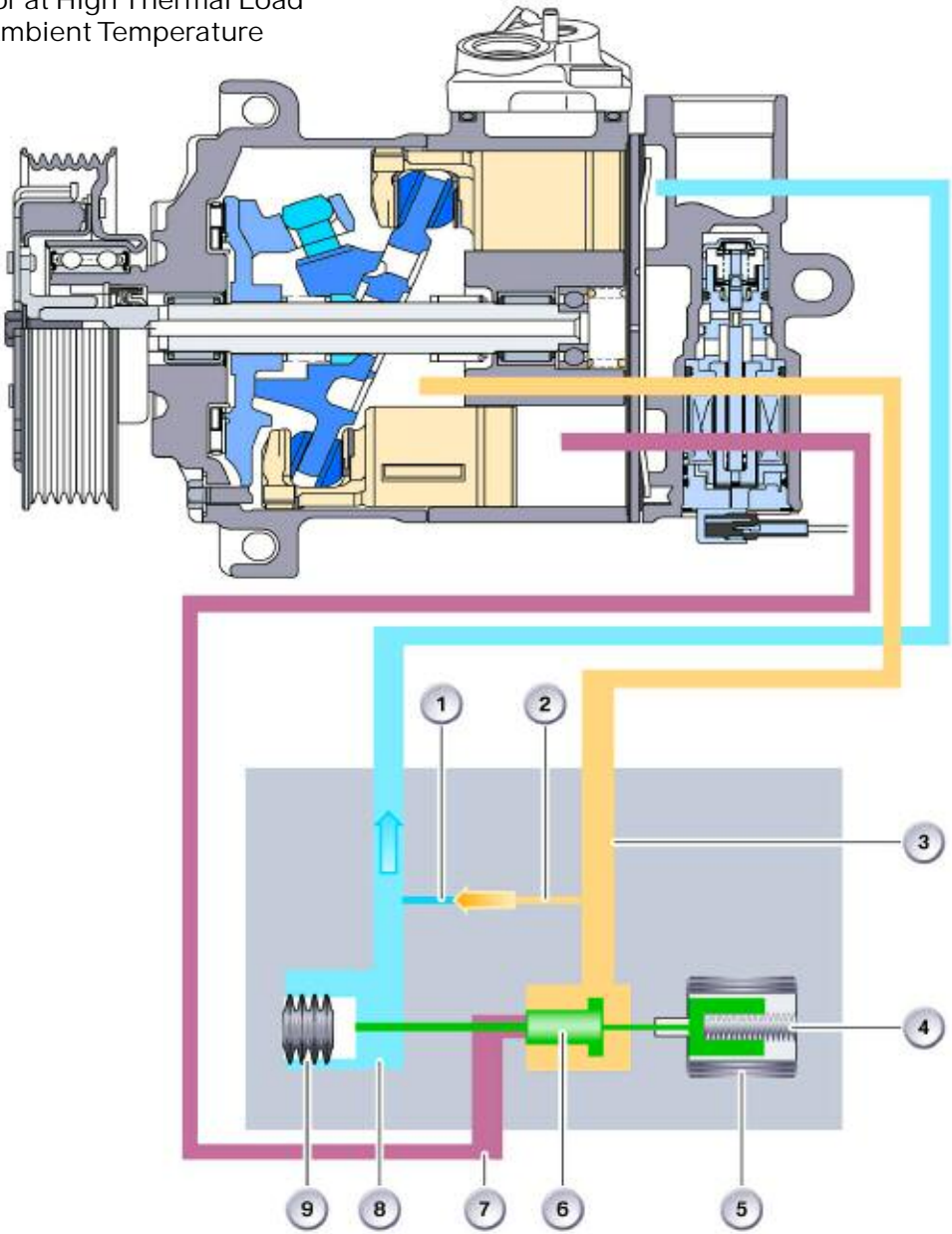

Index	Explanation	Index	Explanation
1	Orifice Between $P_c$ and $P_s$	6	Valve Push Rod
2	Gas flow	7	High Pressure $P_d$
3	Crank chamber pressure $P_c$	8	Intake Pressure $P_s$
4	Spring 2	9	Gaiter With Spring1
5	Coil (Solenoid Valve)		

---

### Control Range of the Compressor

All control positions between the upper stop (100% maximum output) and lower stop (approx. 5% minimum output) are adapted by the varying chamber pressure to the required delivery capacity.

In the case of compressors with constant displacement, adaptation to the required refrigerating capacity is achieved by periodical cut-in and cut-out of the compressor with the aid of the magnetic clutch.

Output-controlled compressors without electric control valves are also cut out using a magnetic clutch. However, this only occurs at very low refrigerating capacity requirement (swash plate position < 5%).

Consequently, the compressor is switched on almost permanently.

The IHKA receives the following inputs:

- Pressure sensor
- Evaporator temperature sensor
- Air conditioning ON/OFF
- Target interior temperature
- Actual interior temperature
- Outside temperature
- Ventilation temperature

Based on these parameters, the IHKA calculates the adequate signal for the compressor control valve to vary the Swash Plate angle and piston displacement in response to thermal load, ambient temperature and climate control settings.

The solenoid valve signal is PWM (Pulse Modulated Signal) with activation at 400Hz and 800 mA

### Blower Motor/Final Stage

The fresh air/recirculated air blower is flange mounted to the right side of the IHKA housing. The specified voltage for the blower is provided by the IHKA (Master) as a defined control signal (PWM signal) via a single-wire interface of the blower output stage (Slave).

The blower motor is actuated by the blower output stage depending on this variable control signal. The line connections from the IHKA to the final stage are monitored by the IHKA.

The blower and the output stage can be replaced separately. See appropriate workshop systems documentation. The motor voltage is limited to 12.5V by the software. If an overload is detected at the output stage output or temperature protection is activated, the engine output is reduced.

### E70 IHKA Blower and Final Stage

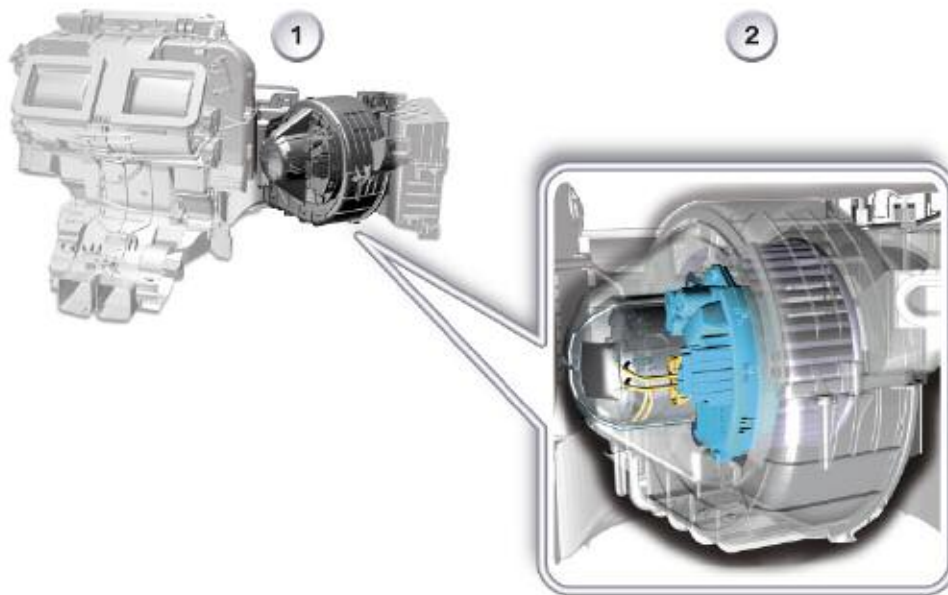

Index	Explanation
1	IHKA blower housing
2	Blower output stage

## Water Valve

The water valves used on the water temperature systems have one inlet and two outlets. The valves are normally sprung open and are pulse width modulated by the IHKA control unit. The IHKA control unit controls the valves via the B+ circuit, both valves are grounded at a common location. The valves are powered closed by the IHKA module when full cooling is needed.

Temperature regulation on IHKA systems is accomplished by solenoid actuated water valve(s). The valve(s) are normally held open by spring pressure (fail safe), and are electrically closed by pulses from the IHKA control module to regulate the flow of hot coolant to the heater core(s).

The water valve(s) are pulsed according to the Y-factor, which is calculated from the following inputs:

- Desired temperature request (left and right if equipped)
- Interior temperature
- Heater core temperature(s)
- Ambient air temperature
- Blower speed request

When the desired temperature calls for maximum heat, the water valve(s) do not receive pulses and are mechanically sprung open. Similarly, when maximum cooling is requested, the IHKA control module powers the water valve(s) completely closed.

E60 Water Valve

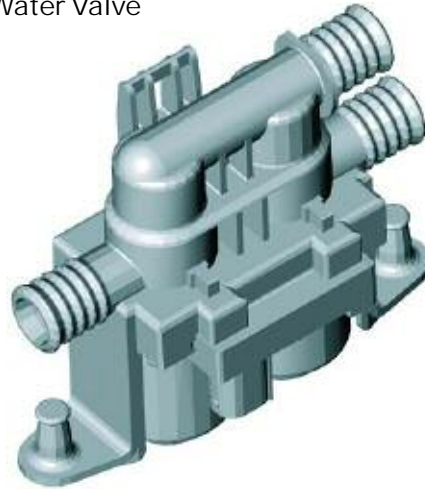

E65 Water Valve



Index	Explanation
1	Left heater core circuit
2	Hot coolant inlet
3	Right heater core circuit

---

### Water Valve (Air Temperature Control)

A water valve that controls the water flow rate through the downstream heater core is not used for setting the temperature in an air-based temperature control system but rather a temperature mixer flap is integrated in the heater/air conditioner.

A single water valve is typically used to control the amount of heat sent to the heater core on an Air Temperature Controlled Systems, although most current vehicles (E85, E9X) don't use one. To control the temperature desired by the dual zone climate control system, air mixing flaps are used.

### Auxiliary Water Pumps

Typically used on Water Regulated Systems. Electrically powered auxiliary coolant pump ensure that an adequate supply of hot coolant is always available to the heater core(s). The IHKA control module operates the pump directly or through a relay by supplying the ground circuit.

Some current vehicles use electric water pumps and don't need to use an auxiliary pump to maintain adequate coolant flow through the heater core.



E60 Auxiliary Water Pump

## Typical Water Based System w/Auxiliary Water Valve

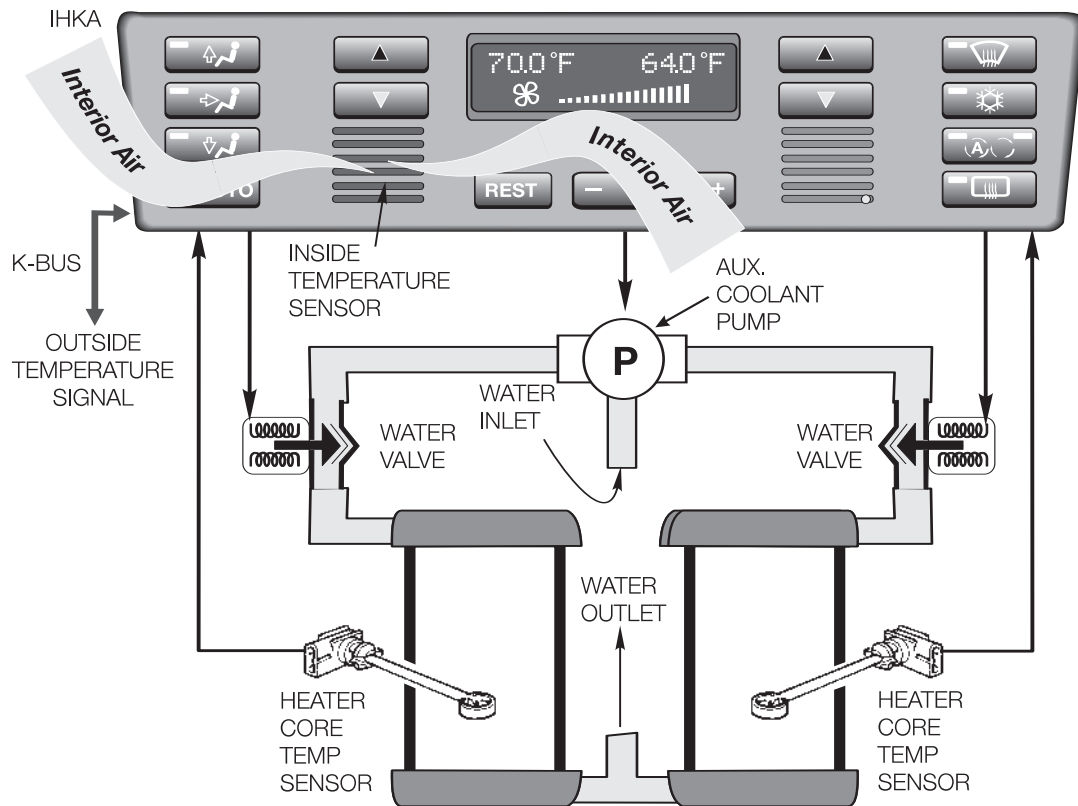

## Electric Water Pumps

The current N52 and N54 engines are equipped with electronically controlled water pumps. Electric water pumps decreased warm up time while enhancing power output and fuel economy.



---

When the residual heat (REST) function is activated, the IHKA control unit interfaces with the DME control module to activate the electric water pump. The water pump allows hot/warm coolant to flow through the heater core and warm the passenger compartment.

The coolant pump of the N54 engine is an electrically driven centrifugal pump with a power output of 400W and a maximum flow rate of 9000 l/h. This represents a significant increase in power of the electric coolant pump used in the N52 engine, which has a power output of 200 W and a maximum flow rate of 7000 l/h.

The DME (ECM) uses the engine load, the operating mode and the data from the temperature sensors to calculate the required cooling output. Based on this data, the DME issues the corresponding command to the electric coolant pump.

The electric coolant pump regulates its speed in accordance with this command. The system coolant flows through the motor of the coolant pump, thus cooling both the motor as well as the electronic module. The coolant lubricates the bearings of the electric coolant pump.

Note: The pump must be filled with coolant when removed for service to prevent any corrosion. Also, the pump impeller must be turned by hand before installation to ensure the pump is not seized.

### Map Thermostat

In view of the fact that an intelligent heat management system has an influence on fuel consumption, exhaust emissions, performance and comfort according to engine temperature, this data-map thermostat was developed for use with such a system.

The data-map thermostat successfully integrates modern engine management electronics. That combination is achieved by placing an electrically heated resistor in the expanding element of the thermostat.

That data map is determined, for example, by the following parameters:

- Engine load
- Engine speed
- Vehicle speed
- Intake-air temperature
- Coolant temperature

## Auxiliary Fan Control (from 99 MY)

The auxiliary fan motor incorporates an output final stage that activates the fan motor at various speeds.

The auxiliary fan is controlled by the ECM. The motor output stage receives power and ground and activates the motor based on a PWM signal (10-100Hz) received from the ECM (DME). The fan is activated based on the following factors:

- Radiator outlet temperature input exceeds a preset temperature.
- IHKA signaled via K and CAN bus based on calculated refrigerant pressures.
- Vehicle Speed
- Battery Voltage Level

When the over-temperature light in the instrument cluster is on (120°C), the fan is run in the overrun function. This signal is provided to the ECM (DME) via the CAN bus. When this occurs, the fan is run at a frequency of 10Hz.

### Typical Auxiliary Fan Control System

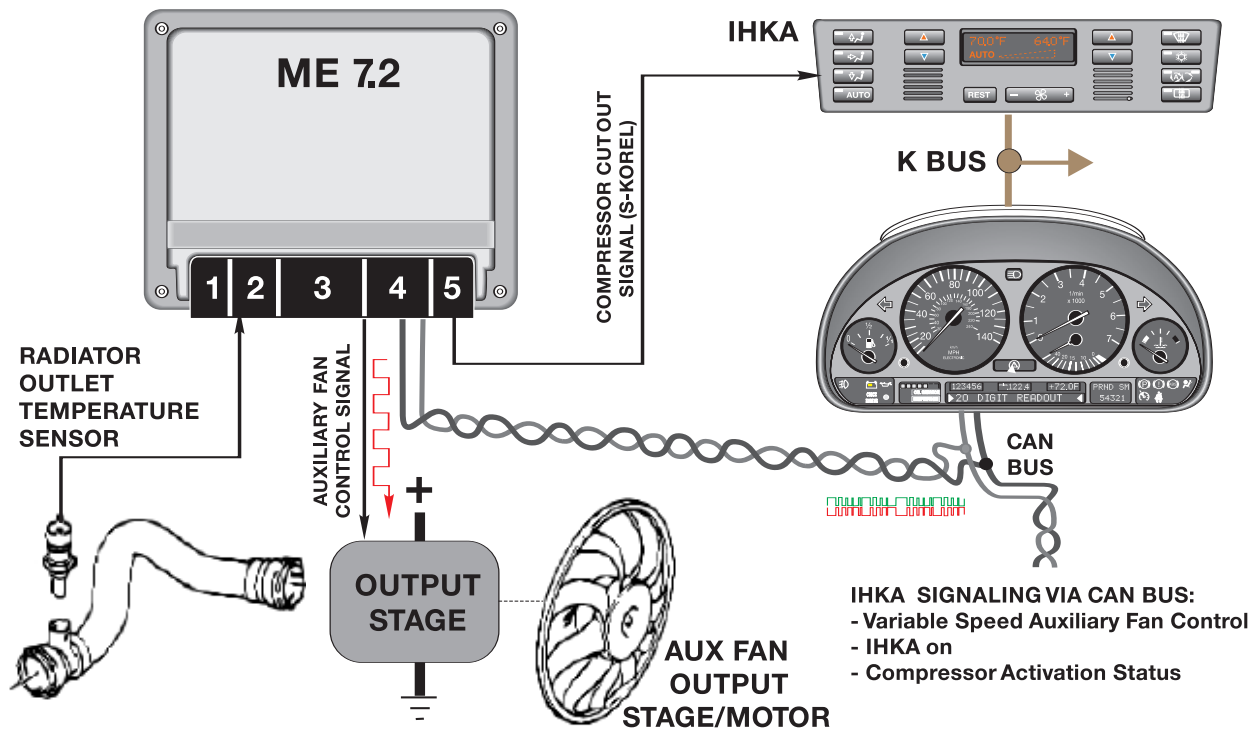



---

## Stepper Motors for Air Flap Operation

BMW IHKR and IHKA Climate Control Systems use 12 volt DC electric stepper motors to operate many of the air inlet, air distribution and temperature mixing flaps. While different types of stepper motors are used on different vehicles, they all share many desirable characteristics:

- Lower power consumption
- Operate in both directions
- Can be started and stopped in any position
- Provide quick movement
- Move in precise increments
- Do not require feedback potentiometers to determine position
- Remain in position when shut off
- Have long service life

Unlike a “normal” 12 volt DC motor (for example, a blower motor) in which the rotor spins through many revolutions per second when the motor receives power a stepper motor rotor rotates through only a small angle when it receives power and then it stops.

A total of four different stepper motor versions are (were) installed in connection with the various heating/air conditioning systems (IHKA, IHKR, IHKS) in all model series.

Each of the early stepper motors, mounted on the various air flaps of the respective systems had different part numbers.

The M-bus stepper motors all feature a fixed programmed address and must therefore be installed in no other position than on the corresponding air flap, they cannot be interchanged.

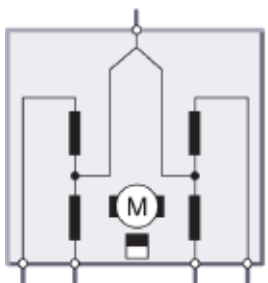

Unipolar stepper motor  
5 connection lines

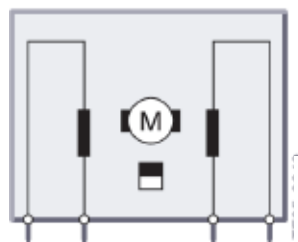

Bipolar stepper motor  
4 connection lines

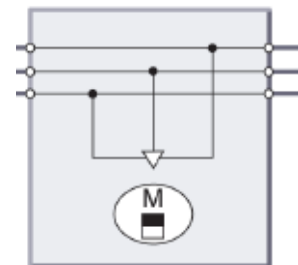

M-bus stepper motor or  
LIN-bus stepper motor  
(bipolar)  
3 connection lines

## Conventional Stepper Motors

Until the E38 was introduced, the stepper motors used in IHKR and IHKA climate control systems did not contain electronic components, and only 3 part numbers were needed to service all the motor assemblies. These motors consisted of copper wire coils wrapped around iron cores (pole pieces), and permanent magnet rotors, all attached to a high-reduction mechanical gearbox. The system electronic control components were located inside the climate control module assembly.

There up to 4 sets of windings in these motors. This circuit arrangement requires from 5-6 wires between the control module and the stepper motor. These motors were used on early climate control systems and are still used on some vehicles for fresh air flap operation.

## “Smart” Stepper Motors

Starting with the E38 climate control system, some of the control module electronics were moved into the stepper motors, making the E38 motors (except the fresh air flaps motor) substantially different from the “conventional” stepper motors we’ve already discussed.

These “Smart” stepper motors use only three wires for operation. There is a power, a ground and the third wire for the “M” bus signal. The “M” bus is used to send messages to the stepper motors. The commands or “messages” are sent by the climate control module. The stepper motors contain processors which will “interpret” the bus messages and actuate the stepper motors to the correct position.

The M-bus stepper motors are different and have a different part number. They all feature a fixed programmed address and must therefore be installed in no other position than on the corresponding air flap, they cannot be interchanged and must be replaced with the same part number as was originally equipped.

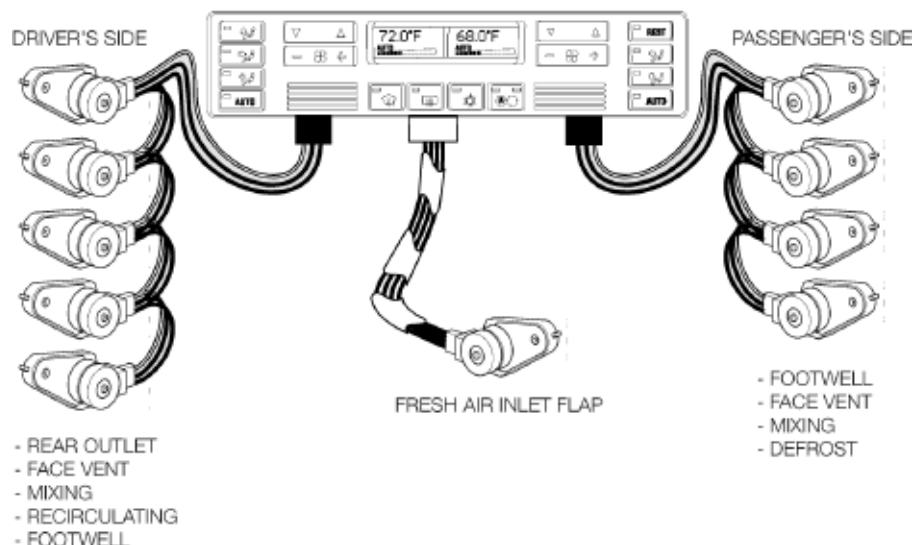

---

The 9 smart stepper motors used on the E38 system share the same set of power, ground, and signal circuits. The left and right branches are connected inside the control module. The fresh air flaps “conventional” stepper motor has its own separate circuits.

These stepper motors have the same type gear box, permanent magnet rotor, and 4 field coils as a “conventional” stepper motor. Plus, it still receives operating signals from the system control module. The stepper motors used on E38/E39/E46 constantly receive power and ground on two of the terminals, and operating instructions on the third.

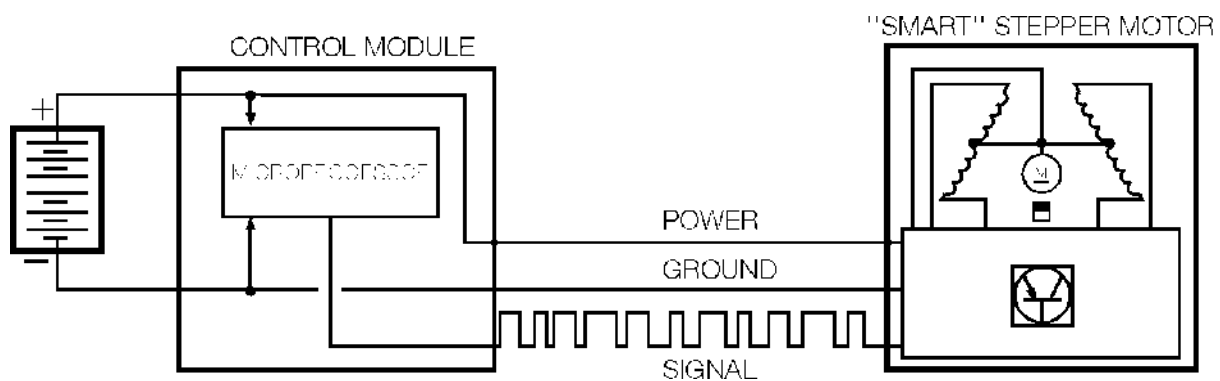

The operating instructions are digital signals which “tell” the stepper motor whether to open or close a flap. The microprocessor inside the stepper motor receives the instructions and converts them into pulses to operate the permanent magnet rotor.

Notice that this 3-wire arrangement (referred to as the M-Bus) allows the control module to operate the motor using only 1 signal circuit instead of the 4 control circuits used previously.

Because the 9 smart stepper motors are connected to the same signal circuit, a total of 35 separate circuits between the control module and the motors can be eliminated. The system operates with just one signal circuit for all 9 motors.

- Each of the 9 stepper motors is different (and has its own part number).
- The control module identifies which motor it wants to operate before it issues the commands.

The part number is clearly marked on every stepper motor, and every stepper motor must be installed in the correct location on the climate control housing.

---

The operating instructions issued to the smart stepper motors by the control module are much more sophisticated than with conventional stepper motors. The sequence of events appears below:

- The control module determines that a flap position must change.
- It issues a “wake-up call” to alert the stepper motors that a command is coming.
- It “names” the motor that is to respond to the command.
- It issues the command signal, e.g. “move 15 steps clockwise”.
- All the stepper motors “hear” the command.
- Only the stepper motor that “hears its name” follows the command.
- The “named” stepper motor then informs the control module that it has carried out the command.

### E65 Stepper Motors

The E65 IHKA has a total of 11 stepper motors, 1 Rapid action motor for the fresh air flap and 10 Stepper motors for all other flaps Each of these motors contain an integrated circuit (MUX- 4 chip) in the plug connection housing.

This IC controls the windings of the motor and is linked by a motor bus with diagnosis capabilities.

All stepper motor drives are controlled by the IHKA control module over the motor bus.

Each drive has a permanent address (stored on the chip) which is a unique identifier for the individual motor (for bus communication). The stepper motors are all different and are not interchangeable.

Faults (blockages) reported by the drives are stored in the IHKA control module, which responds by discontinuing control signals to the motor in question.



E65 Stepper Motors

## E60 Stepper Motors

The E60 IHKA system uses 9, MUX5 motors (multiplex motor type 5). These stepper motors have different part numbers, are connected to the LIN Bus in parallel and are not interchangeable.

The LIN Bus replaced the M-Bus. This bus circuit consists of three wires, power (B+), ground and the LIN bus signal wire.

The stepper motors for the fresh air/recirculation air flaps are designed as high speed motors. This system does not use any bowden cables for flap actuation.

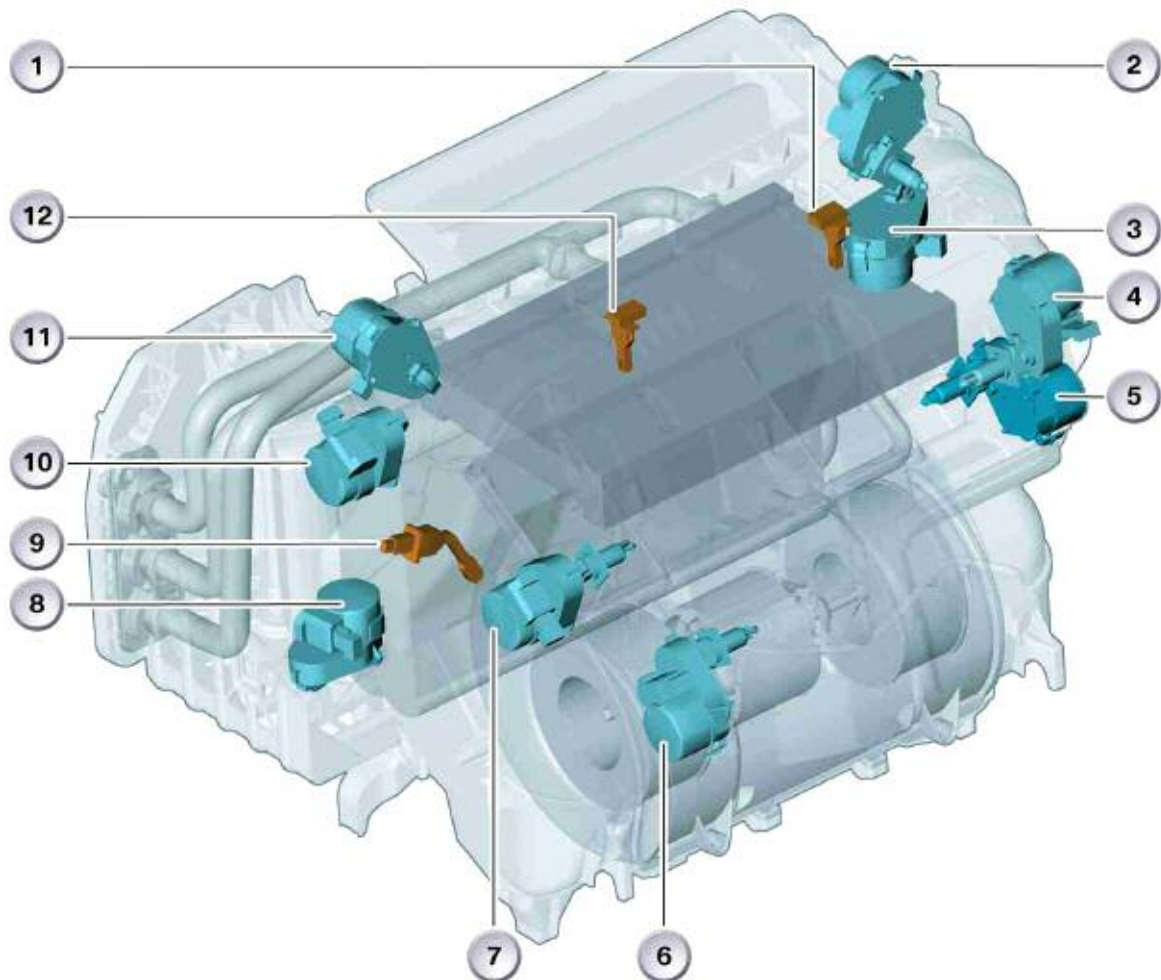

E60 Stepper Motors and Sensors

Index	Explanation	Index	Explanation
1	Heater Core Temperature Sensor (RH)	7	Stepper Motor, left side ventilation
2	Stepper Motor, right footwell	8	Stepper Motor, fresh air/recirculated air (LH)
3	Stepper Motor, fresh air/recirculated air (RH)	9	Evaporator Temperature Sensor
4	Stepper Motor, right side ventilation	10	Stepper Motor, defrost
5	Stepper Motor, air stratification	11	Stepper Motor, left footwell
6	Stepper Motor, rear compartment (center)	12	Heater Core Temperature Sensor (LH)

## E9X Stepper Motors

The current E9X IHKA systems utilizes eight stepper motors that are wired in series for climate control operation. The IHKA control module also operates the stepper motors via the LIN-bus.

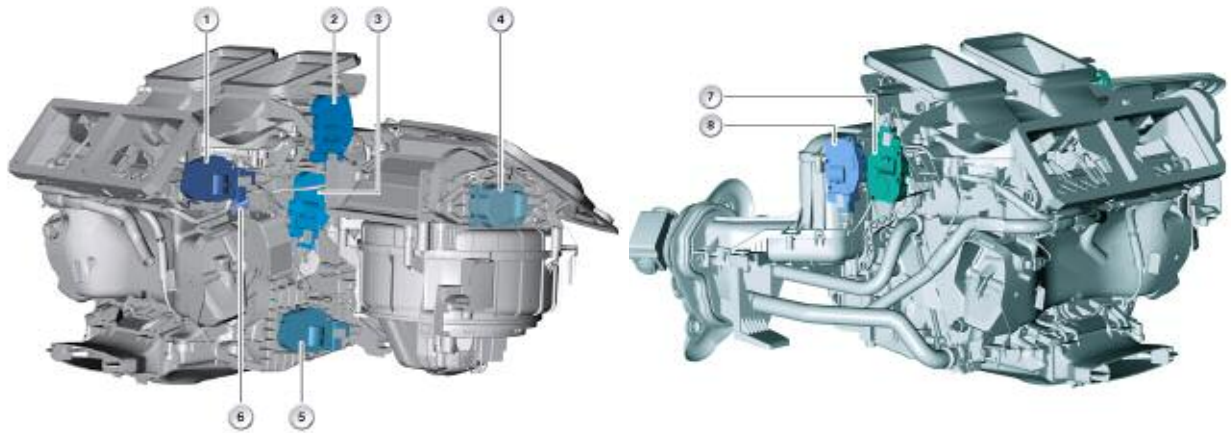

Index	Explanation	Index	Explanation
1	Stepper Motor, Ventilation Flap	5	Stepper Motor, Air Blending, Rear
2	Stepper Motor, Defroster Flap	6	Stepper Motor, Footwell
3	Stepper Motor Air Mixing Flap, Right	7	Stepper Motor, Air Mixing Flap, Left
4	Stepper Motor, Fresh / Recirculating Air	8	Stepper Motor, Air Blending, Front

- All eight stepper motors can be replaced without removing the dashboard or A/C housing.
- Seven of the eight stepper motors used are identical (same part number).
- A different stepper motor is used only for the fresh air/recirculation motor. "See the Service Information section".
- Flap motors are wired in series.
- Each flap motor has a measuring resistance of approx. 1 ohm.

Each flap motor is connected to its predecessor via this measuring resistance. For this reason, troubleshooting must be performed in the order stipulated in the schematic circuit diagram. A new generation of stepper motors is used in the E90/E91/E92/E93 systems as well as in the current E70.

These stepper motors feature two LIN bus connection lines (input/output). A motor has only one LIN-bus input on the wiring harness (foot-well motor). The motors are connected in series (the foot-well motor is the last motor in the series connection).

Also in this case there are two different versions. The motor with the designation EFB is used for all air flaps except the fresh air flap as well as in IHR and IHKR for the central (mechanism) kinematics with  $1\Omega$  resistor.

The motor with the designation EAB is used for the fresh air flap and the central kinematics (Air Distribution Mechanisms). The EAB motor varies its speed corresponding to the force applied at the flap. Faster at a low load force and slower at a high load force (with no  $1\Omega$  resistor).

Circuit Diagram - EAB Stepper Motor

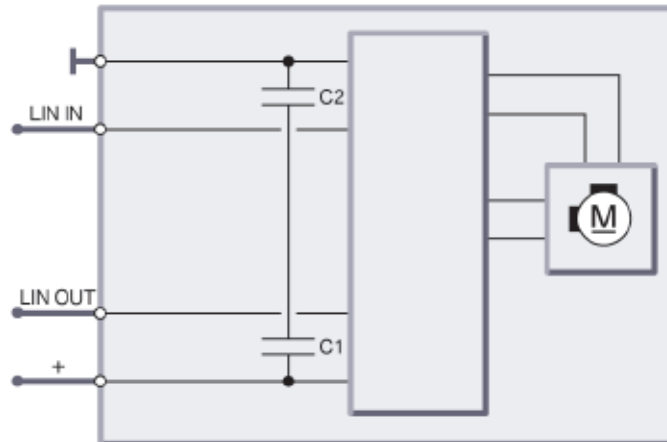

EAB Stepper Motor

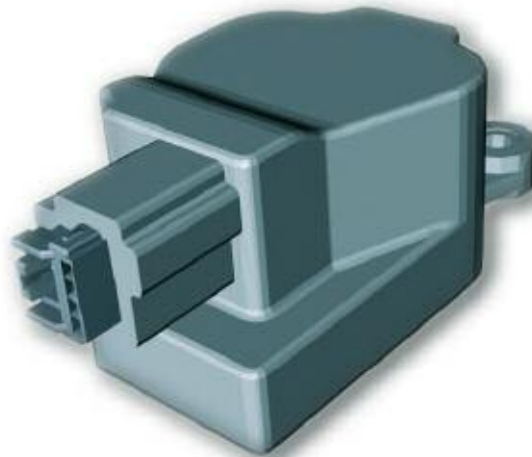

The EFB motor has a constant displacement speed and a defined moment. The EFB motors are all identical and must therefore be programmed. The air flap motors are connected in series. A 1Ω measuring resistor is installed in each air flap motor. The following air flap motor is connected to the one before it via this measuring resistor or shunt. The motors must be connected only in the sequence as shown in the schematic circuit diagram.

Circuit Diagram - EFB Stepper Motor

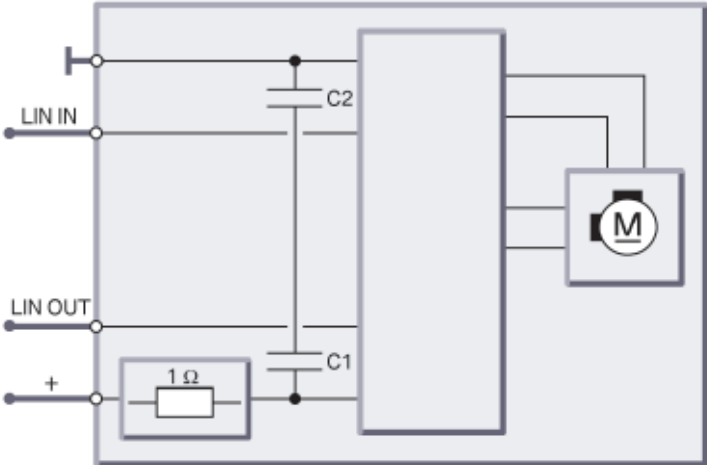

EFB Stepper Motor

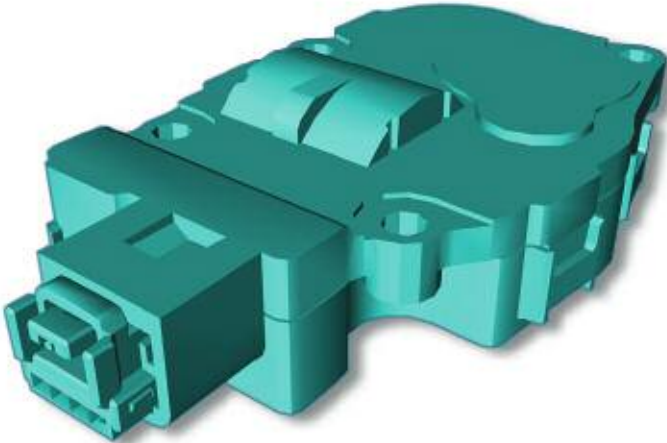



E70 Stepper Motors

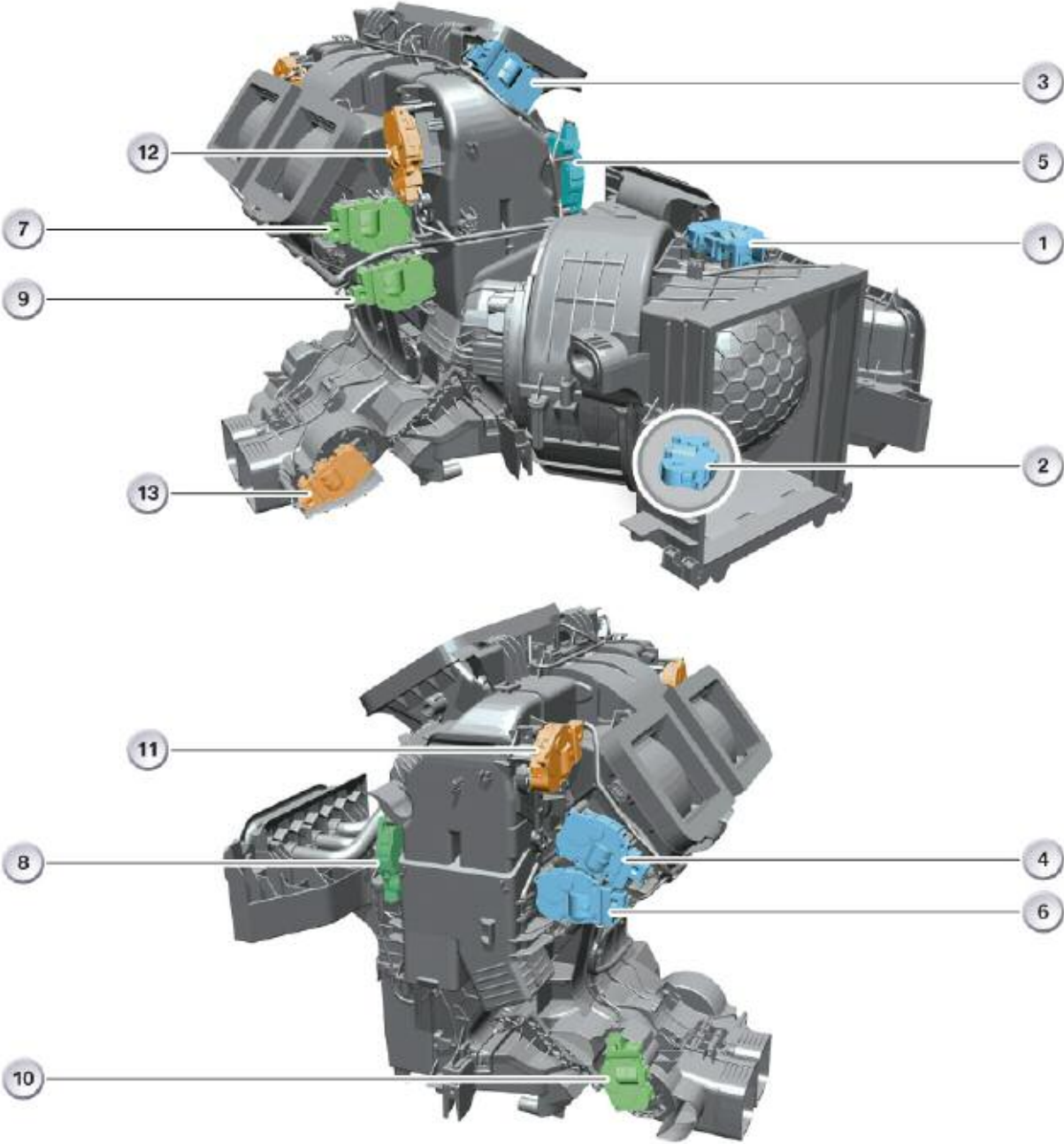

## E70 Stepper Motors

The IHKA actuator stepper motors used on the E70 are the same as in the E9X. They are all designed as identical components and are actuated by the IHKA via the LIN bus.

When an actuator motor is being replaced it must be ensured that the correct plug is connected to the relevant motor from the wiring harness end. The plug order can be found in the wiring diagram.

Then an addressing run must be started using the BMW diagnostics system. The IHKA detects the actuators that are connected in series and assigns an address to the new motor if necessary.

The actuation of the addressing run is integrated in the diagnostics system in the service function (re-address body, heating/air conditioning functions, flap motors). A function test (reference run) is also integrated in the diagnostics system, with which the operational capability and the adjusting path of the motors can be tested.

	Actuator motors	IHKA	IHKA w/ FKA
1	Fresh air/recirculated air, actuator motor	√	√
2	Dynamic pressure compensation, actuator motor	√	√
3	Defrost, actuator motor	√	√
4	Left/right front ventilation, actuator motor	√	√
5	Right/left front footwell, actuator motor	√	√
6	Right/left front air stratification, actuator motor	√	√
7	Right front ventilation, actuator motor	√	√
8	Left front footwell, actuator motor	√	√
9	Right front air stratification, actuator motor	√	√
10	Left/right rear air stratification, actuator motor	√	√
11	Left rear footwell, actuator motor	Not used	√
12	Right rear footwell, actuator motor	Not used	√
13	Right rear air stratification/shut-off, actuator motor	Not used	√

## IHKA 4-zone, Overview of Air Distribution Flaps

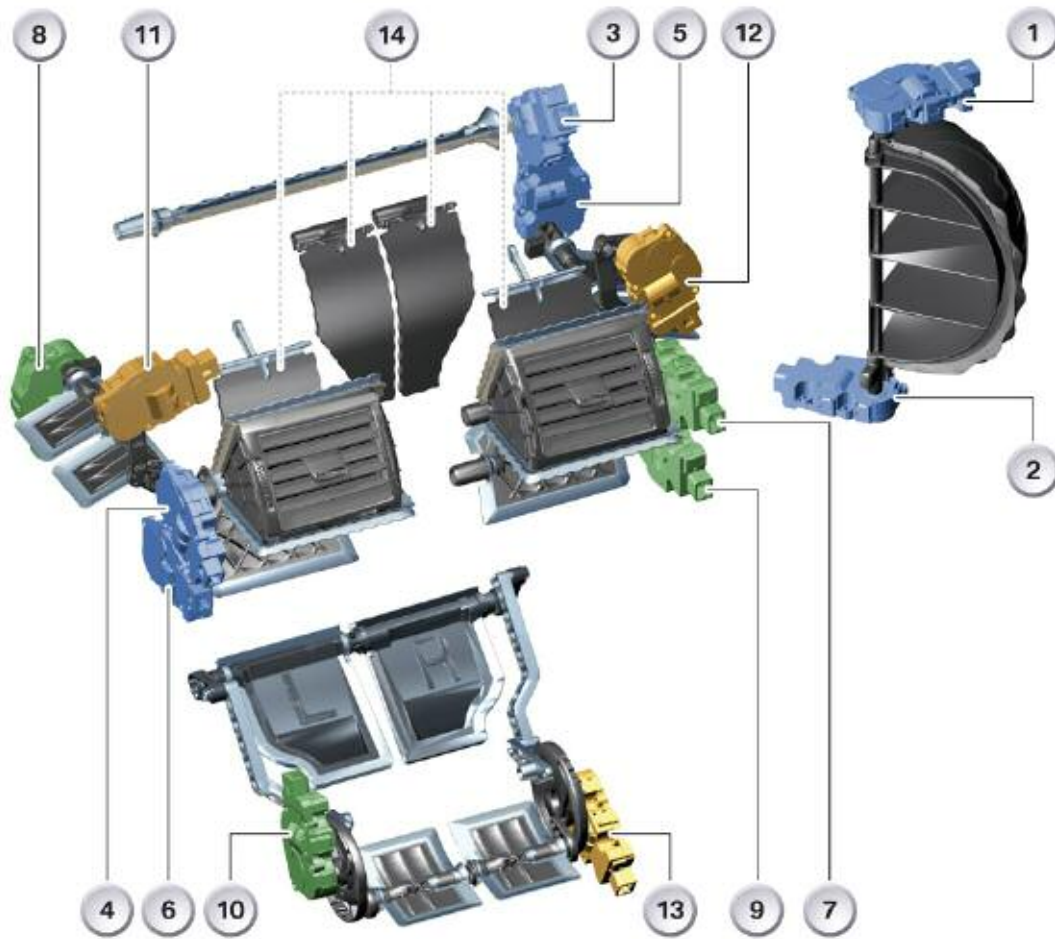

Index	Explanation
1	Actuator motor, fresh air/recirculating air
2	Actuator motor,dynamic pressure compensation
3	Actuator motor, defrost
4	Actuator motor, front left ventilation
5	Actuator motor, front right footwell
6	Actuator motor, front left air stratification
7	Actuator motor, right front ventilation
8	Actuator motor, left front footwell
9	Actuator motor, right front air stratification
10	Actuator motor, left rear air stratification
11	Actuator motor, left rear footwell
12	Actuator motor, right rear footwell
13	Actuator motor, right rear air stratification/shut-off
14	Housing internal non-return flaps

---

## Replacement of a Flap Motor

After replacement, the flap motor must be addressed. The addressing procedure is initiated with the BMW diagnostic Equipment.

The IHKR or IHKA control unit automatically assigns the address to the flap motor. The motor recognizes its assignment (address e.g. footwell motor) based on an addressing current.

This arrangement makes it possible to use a standard motor for all air distribution flaps. The motor must not be turned by hand as this would pose the risk of irreparably damaging the electronics or the gear mechanism.

The new address will be triggered by the diagnosis software via:

Service Functions => Body => Heating and Air Conditioning => re-address motors

The flap motor will automatically receive the address from the IHKA control unit. The control unit will recognize the correct address from the order of flap motors.

Because of this, care should be taken during the exchange the each flap motor is connected in the correct order to the correct connector.

The correct order for the stepper motors is:

1. Defroster flap
2. Fresh/Recirculating air flap
3. Ventilation flap
4. Rear blending/stratification flap
5. Right air mixing flap
6. Front blending/stratification flap
7. Left air mixing flap
8. Footwell flap

Note: Flap motors are wired in series. Each flap motor has a measuring resistance of approximately 1 ohm. Each flap motor is connected to its predecessor via this measuring resistance. For this reason, troubleshooting must be performed in the order stipulated in the schematic circuit diagram.

E90 IHKA System Diagram

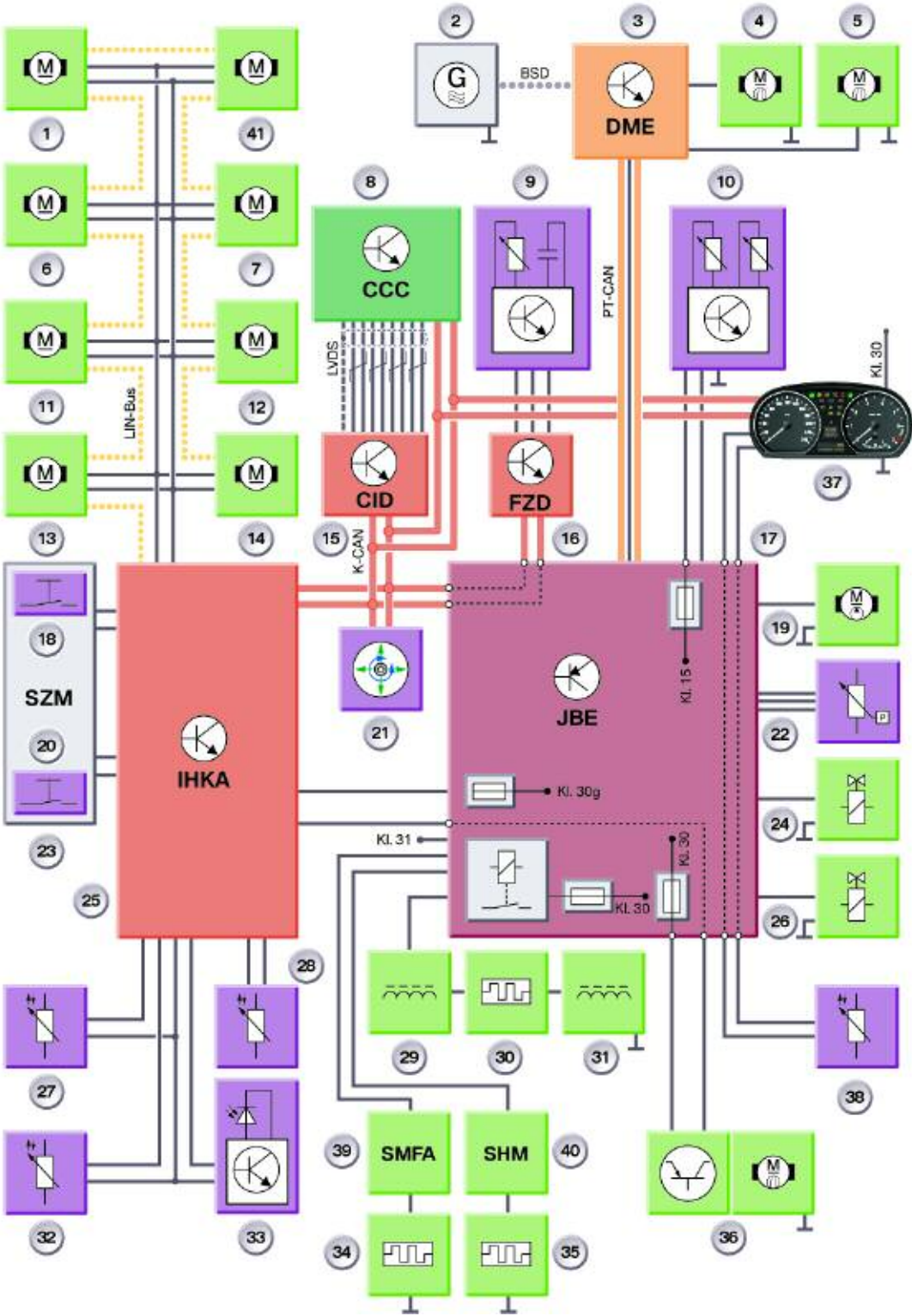

## E90 IHKA System Diagram Legend

Index	Explanation	Index	Explanation
1	Rear blend/stratification motor	22	Pressure sensor
2	Alternator	23	Center console switch cluster (SZM)
3	Digital motor electronics (DME)	24	Water valve
4	Electric water pump	25	Outside temperature sensor
5	Engine cooling fan	26	Auxiliary water pump (not for US)
6	Ventilation motor	27	Evaporator temperature sensor
7	Front blend/stratification motor	28	Footwell temperature sensor
8	Car communication computer (CCC)	29	Blocking circuit (filter)
9	Condensation sensor	30	Rear window defogger
10	AUC II sensor	31	Blocking circuit (filter)
11	Fresh air/recirculation motor	32	Ventilation temperature sensor
12	Mix air flap motor, left	33	Solar sensor (1-channel)
13	Defrost flap	34	Seat heating element, left
14	Footwell flap motor	35	Seat heating element, right
15	Central information display (CID)	36	Blower motor and final stage
16	Roof function center (FZD)	37	Instrument Cluster
17	Junction Box Electronics Control Module (JBE)	38	Outside temperature sensor
18	Seat heater button, left	39	Driver's seat module
19	A/C compressor valve	40	Seat heating module (passenger)
20	Seat heater button, right	41	Mix air flap motor, right
21	Controller		

## PTC Heating Elements

On the E70 in order to provide 4 temperature zones BMW uses PTC heating elements. Installed at the left and right side rear footwell air channels for the second row of seats FKA, The heating elements act as auxiliary comfort heaters and provide the occupants with a way of offsetting the rear temperature compared to the front temperature, regardless of the heating situation in the front.

The heating elements are operated by the FKA via a PWM signal depending on the rear footwell outlet temperature and any output capability limitations.

The nominal rating of the PTC heating element is 300W with a voltage of 13V and air flow rate of 1 kg/min.

Index	Explanation
1	PTC heater element
2	Outlet temperature Sensor

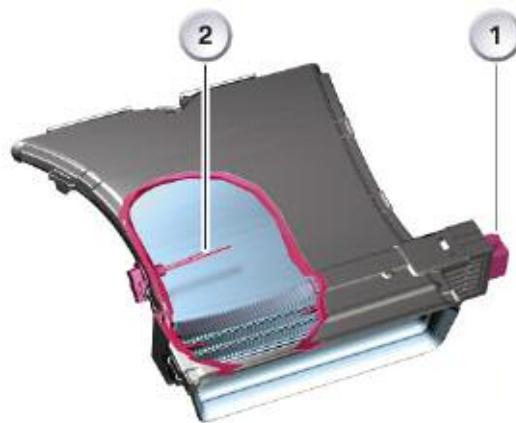

## FKA Control Unit

The FKA is incorporated in the vehicle system via the K-CAN. The FKA operating unit and control unit have a 12-volt and a 5-volt power supply area.

The footwell and ventilation temperature sensors and the air stratification potentiometer are supplied with 5 volts by the FKA.

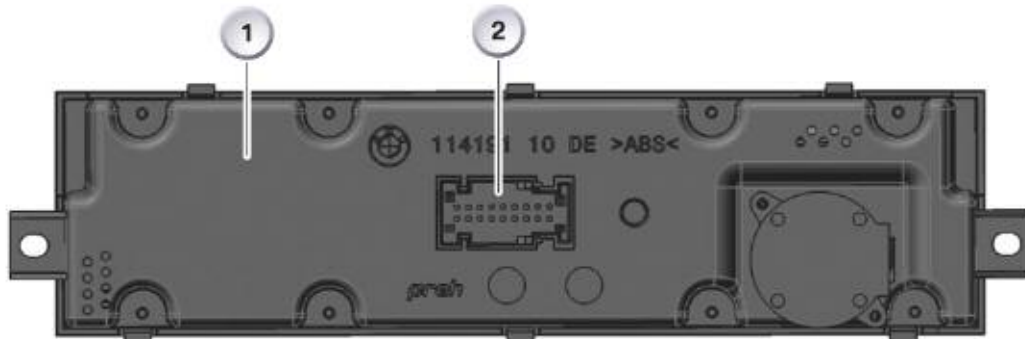

(1) FKA Control Unit Rear View, (2) Plug Connector

E70 IHKA w/FKA PTC Heaters

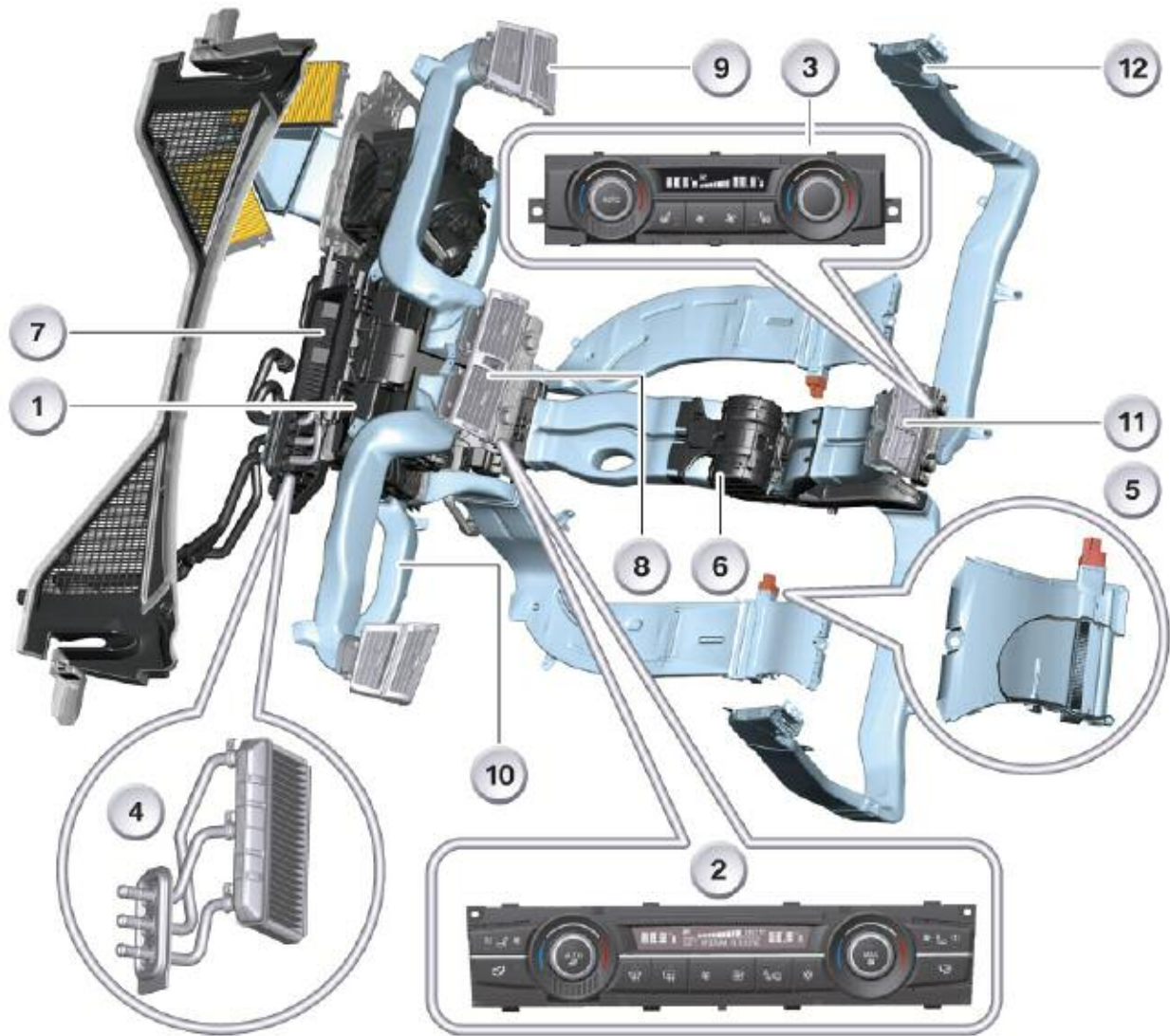

Index	Explanation	Index	Explanation
1	IHKA with FKA	7	Defrost air outlet
2	IHKA, dual front temperature controls	8	Center Ventilation air outlet, front left/right
3	FKA, dual rear temperature controls	9	Ventilation air outlet, front left/right
4	Two inlet pipes to HWT, two water valves	10	Footwell air outlet, front left/right
5	PTC heating element in footwell air ducts rear left/right	11	Rear ventilation air outlet, center, left/right
6	Rear blower (FKA)	12	Ventilation air outlet, B-pillar left/right



### E70 Third Row Heating and Ventilation PCT Heater

The 3rd row of seats HB3SR has its own optional heating and ventilation system. A PTC heating element is activated via the limit position switch operated by the knurled adjusting wheel.

Warm air is blown out via the lower ventilation air vents. The heating can only be activated if the blower is switched on.

The control unit for heating and ventilating the 3rd row of seats is connected to the IHKA via the LIN bus and controls the heating element (output 300W) for heating the air in the footwell of the 3rd row of seats.

The output of the heating element is controlled depending on the interior temperature in three stages from 0 - 100% (< 20°C = 100%, > 20°C = 50%, > 30°C = 0% PTC output).

The DME (ECM) (by means of a CAN signal to the IHKA and to the HB3SR control unit via the LIN bus) can reduce the power of the heating element (power reduction of 50% or cut off) within the scope of power management.

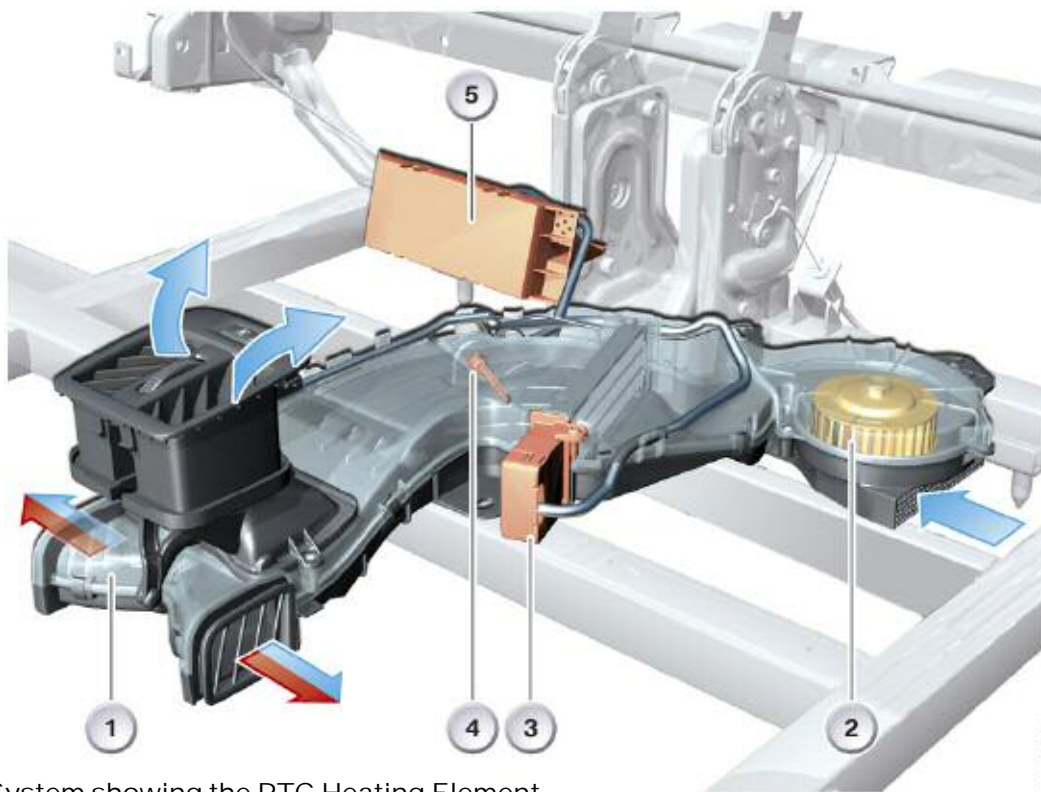

HB3SR System showing the PTC Heating Element

Index	Explanation	Index	Explanation
1	System unit for heating and ventilating the 3rd row of seats	4	Auxiliary heating temperature sensor.
2	Ventilation blower and heating for 3rd row of seats, recirculated air intake	5	HB3SR control unit
3	PTC heating element		

E70 IHKA w/FKA Ventilation Component Identification

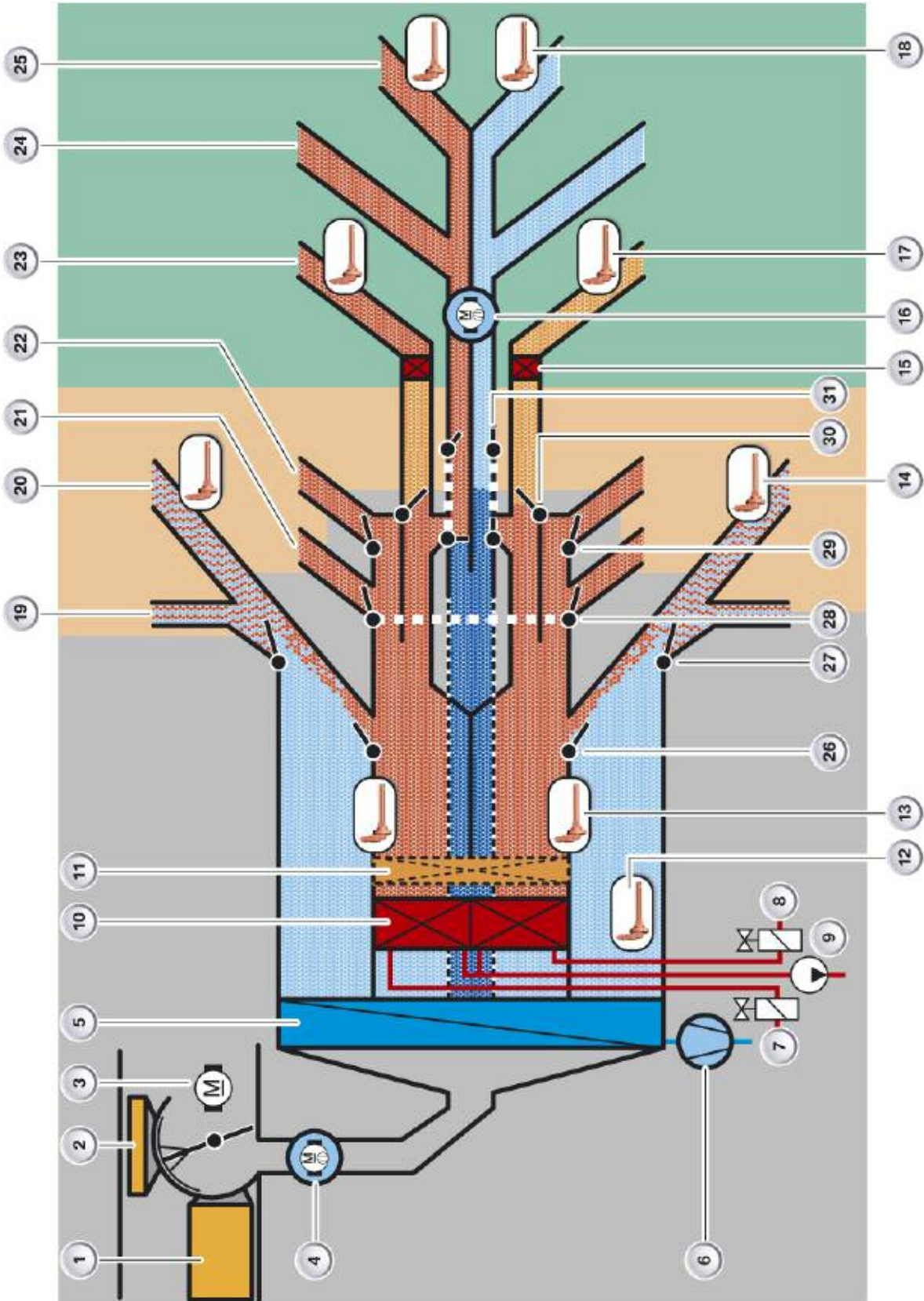

## E70 IHKA w/FKA Ventilation Component Identification Legend

Index	Explanation	Index	Explanation
1	Fresh air cabin filter	17	Left and right FKA rear footwell vent temperature sensors
2	Recirculating air cabin filter	18	Left and right FKA rear center vent temperature sensors
3	Fresh air flap	19	Left and right front corner dash vents
4	Front blower motor	20	Left and right front center dash vents
5	Evaporator	21	Left and right front footwell vents
6	Expansion Valve	22	Left and right front footwell vents
7	Heater control valve passenger	23	Left and right rear footwell vents
8	Heater control valve driver	24	Left and right B pillar vents
9	Auxiliary water pump (N62 only)	25	Left and right rear center vents
10	Heater core	26	Left and right front dash vents air stratification flaps
11	Auxiliary PTC heater (not for US vehicles)	27	Left and right front dash vent control flaps
12	Evaporator temperature sensor	28	Left and right front footwell vent control flaps
13	Left and right heater core temperature sensors	29	Left and right front footwell vent air flow control flaps
14	Left and right front center dash vent temperature sensors	30	Left and right FKA rear footwell air flow control flaps
15	Left and right FKA rear footwell PTC heater elements	31	Left and right rear center and B pillar air stratification flaps
16	FKA rear blower motor		