Table of Contents

Subject	Page
MS S542
Objectives of the Module2
Purpose of the System3
System Components4
Power Supply6
Principle of Operation7
Workshop Hints8
Tools and Equipment9
Air Management10
Principle of Operation14
Workshop Hints21
Tools and Equipment23
Fuel Management24
Principle of Operation33
Workshop Hints39
Tools and Equipment45
Ignition Management47
Principle of Operation53
Workshop Hints57
Tools and Equipment61
Emissions Management62
Evaporative Emissions62
Exhaust Emissions65
Principle of Operation70
Workshop Hints.81
Tools and Equipment82
Performance Controls84
Review Questions88

MS S54

Model: E46 M3 S54B32 Engine

Production Date: 01/2001

Manufacturer: Siemens

Pin Connector: 134 Pins - 5 Modular Connectors

Objectives of the Module

After completing this module, you will be able to:

- Describe the Power Supply for the Fuel Injectors and Ignition Coils
- Understand the EDR and Idle Air Actuator Operation
- Name the Component Location of the Fuel Supply System
- List the Inputs Required for Fuel Injector Operation
- Describe Emission Optimized Function
- Name the Two Types of Emissions the ECM Controls
- Explain Why Two Sensors are used to Monitor Throttle Movement
- Describe the Dual Input from the Accelerator Pedal
- Locate the Diagnostic Socket

MS S54

Purpose of the System

The MS S54 system manages the following functions:

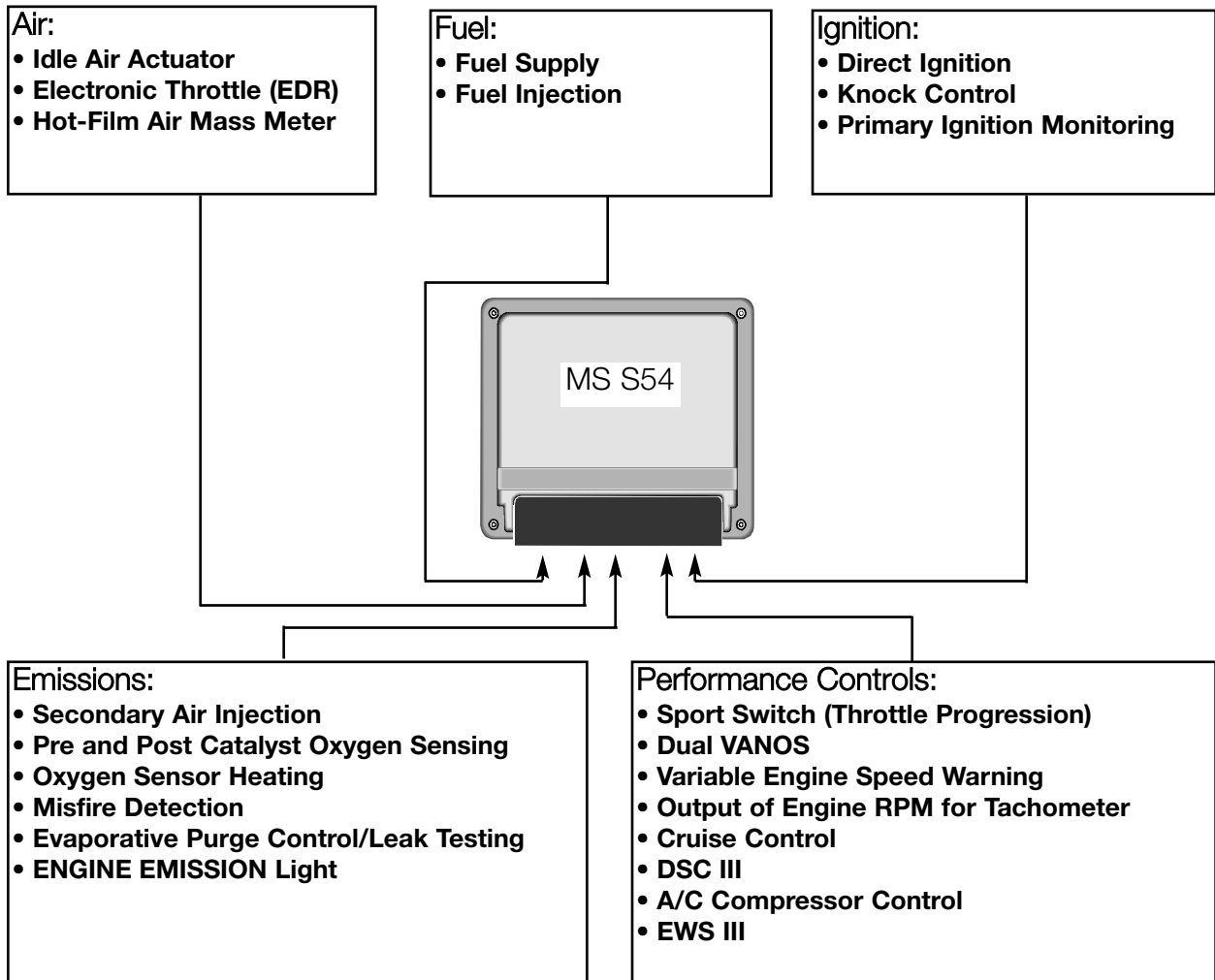

System Components

MS S54 Engine Control Module: The MS S54 ECM features a single printed circuit board with two 32-bit microprocessors.

The task of the first processor is to control:

- Engine Load
- Electronic Throttle (EDR)
- Idle actuator
- Ignition
- Knock Control

The task of the second processor is to control:

- Air/Fuel Mixture
- Emission Control
- Misfire Detection
- DMTL



12410000.tiff

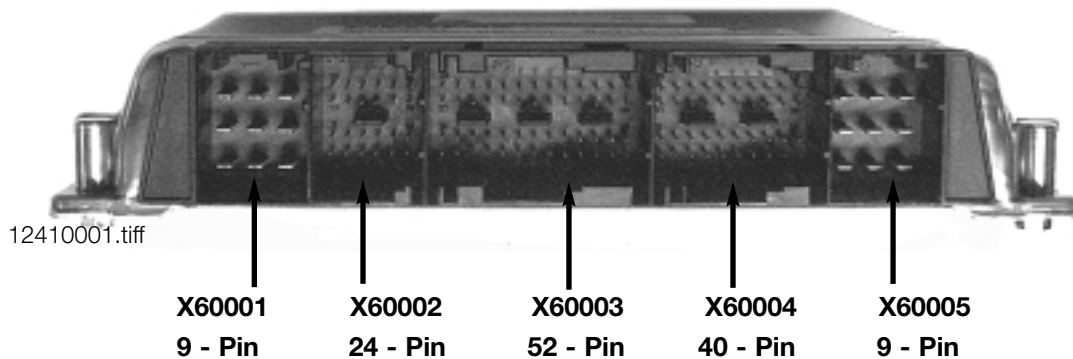

The 134 pin MS S54 Engine Control Module is manufactured by Siemens to BMW M specifications. The ECM is the SKE (standard shell construction) housing and uses 5 modular connectors. For testing, use the Universal Adapter Set (break-out box) Special Tool: # 90 88 6 121 300.

MS S54 ECM

Inputs - Processing - Outputs

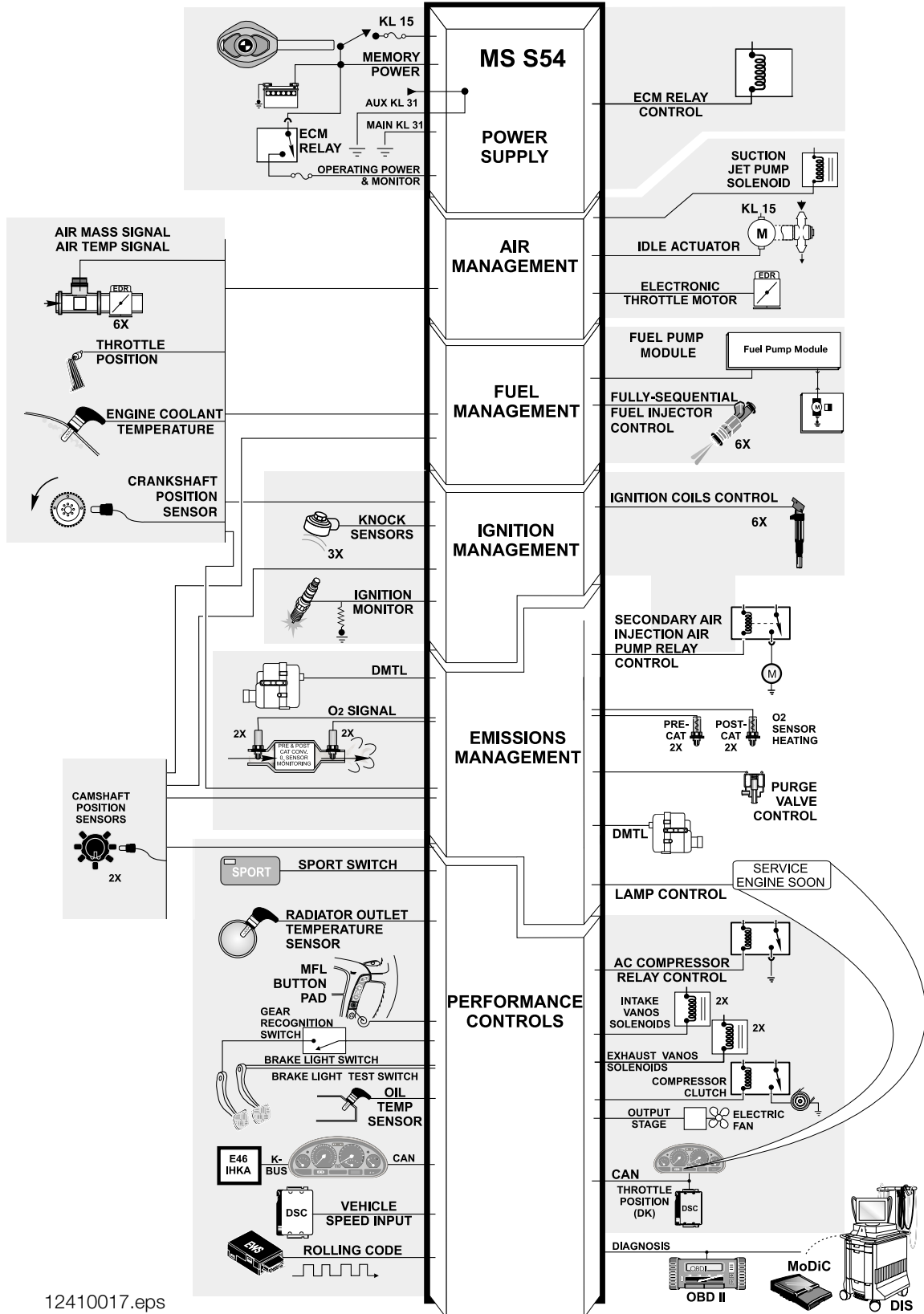

12410017.eps

Power Supply

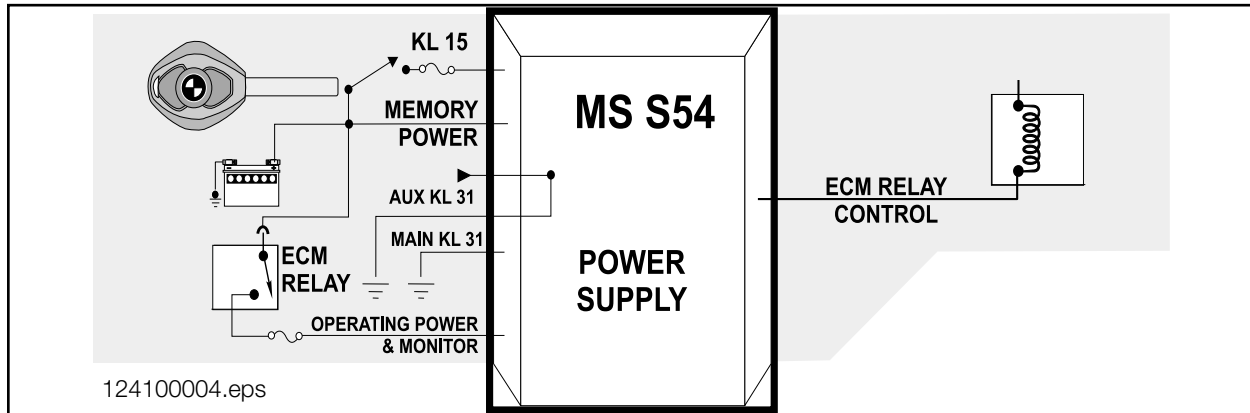

KL30 - Battery Voltage: B+ is the main supply of operating voltage to the ECM.

Power Supplies: The power supplies (KL15 and ECM Relay) are fused to the MS S54 ECM. The fuses are housed in the Engine Fuse Block located in the Electronics Box.

KL15 - Ignition Switch: When the ignition is switched “on” the ECM is informed that the engine is about to be started. KL15 (fused) supplies voltage to the Engine Control Module Relay and the Fuel Injector Relay. Switching KL15 “off” removes the ECM operating voltage.

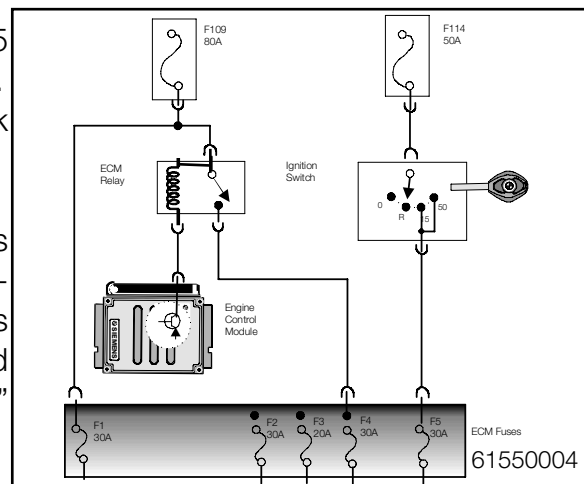

Engine Control Module Relay: The ECM Relay provides the operating voltage for:

1. ECM	6. Ignition Coils
2. Fuel Injector Relay	7. DMTL
3. Idle Air Actuator	8. Camshaft Sensor
4. Evaporative Emission Valve	9. Hot Film Air Mass
5. Fuel Pump Relay	10. Oxygen Sensor Heaters

Ground: Multiple ground paths are necessary to complete current flow through the ECM. The ECM ground pin numbers are:

Connector X60001	Connector X60004	Connector X60005
Pin 4 - Ground for ECM	Pin 5 - Ground for ECM	Pin 5 - Ground for ECM
Pin 5 - Ground for ECM		
Pin 6 - Ground for ECM		

Principle of Operation

Battery Voltage is monitored by the ECM for fluctuations. It will adjust the output functions to compensate for a lower (6v) and higher (14v) voltage value. For example, the ECM will:

- Modify pulse width duration of fuel injection.
- Modify dwell time of ignition.

When **KL15** is switched “on” the ECM is ready for engine management. The ECM will activate ground to energize the Engine Control Module Relay. The Engine Control Module Relay supplies operating voltage to the ECM and the previously mentioned operating components. Five seconds after the ignition is switched on and the voltage at the KL15 input is >9 volts, the ECM compares the voltage to the ECM Relay supplied voltage. If the voltage difference between the two terminals is greater than 3 volts, a fault code will be set.

When **KL15** is switched “off” the ECM operating voltage is removed. The ECM will maintain a ground to the Engine Control Module Relay for a few seconds to maintain ignition coil activation (Emission Optimized - introduced in 2000 MY).

Ground is required to complete the current path through the ECM. The ECM also:

- Internally links a constant ground (1) to the engine sensors.
- Switches ground (2) to activate components.

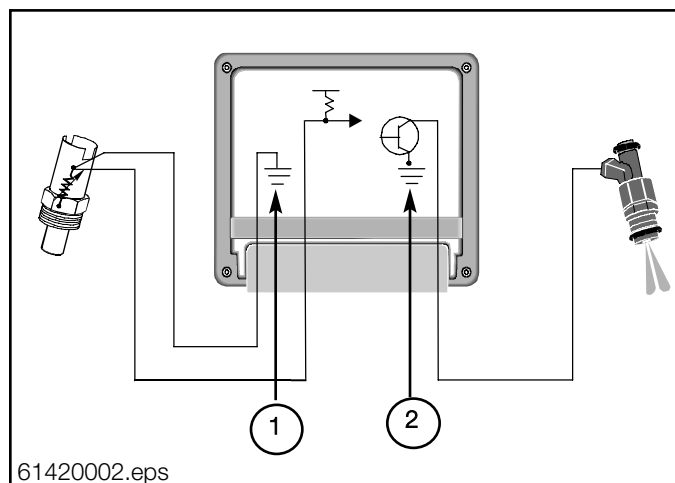

Workshop Hints

Power Supply - Testing

Inadequate power and ground supply can result in:

1.	No Start
2.	Hard Starting (Long Crank Times)
3.	Inaccurate Diagnostic Status or ECM (Not Found)
4.	Intermittant / Constant "ENGINE EMISSION" Light
5.	Intermittant/Constant Driveability Problems

Power supply including fuses should be tested for:

1.	Visual (1) Blown Fuse
2.	Available Voltage (2)
3.	Voltage Drop (Dynamic Resistance) (2)
4.	Resistance of Cables and Wires (2)

The ignition (KL15) must be switched off when removing or installing the ECM connector to prevent voltage spikes (arcing) that can damage the Control Module!

The Engine Control Module Relay (located in the Electronics Box) should be tested for:

1.	Battery Voltage and Switched Ground (1)
2.	Resistance (1)
3.	Battery Voltage and Voltage Drop (2)

Electronics Box - ECM and Fuses

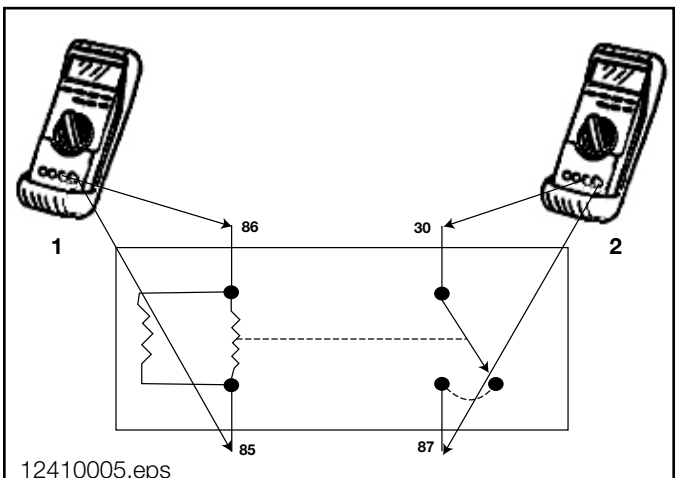
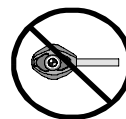
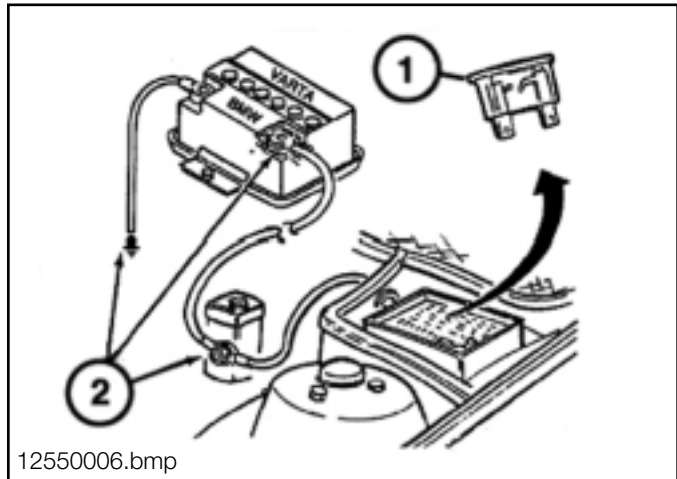

Tools and Equipment

Power Supply

When testing power supply to an ECM, the DIS/MoDIC multimeter function as well as a reputable hand held multimeter can be used.

It is best to make the checks at the ECM connection, this method includes testing the wiring harness.

The correct Universal Adapter for the MS S54 application should be used (#90 88 6 121 300). This will ensure the pin connectors and the harness will not be damaged.

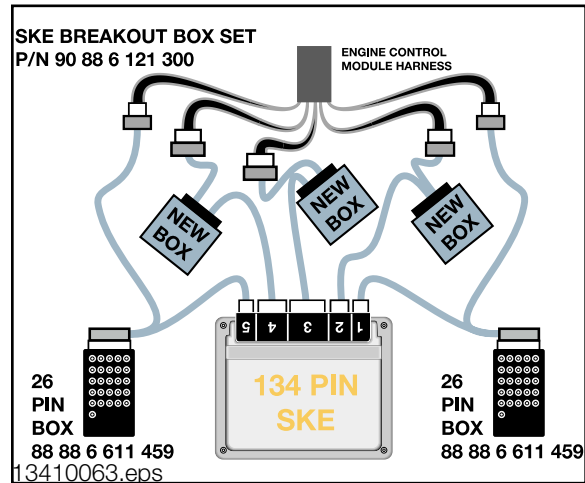

When installing the Universal Adapter to the ECM (located in the Electronics Box in engine compartment), make sure the ignition is switched off.



12410002.tiff



The Engine Control Module **Relay** should be tested using the relay test kit (P/N 88 88 6 613 010) shown on the right.

This kit allows testing of relays from a remote position.

Always consult the ETM for proper relay connections.

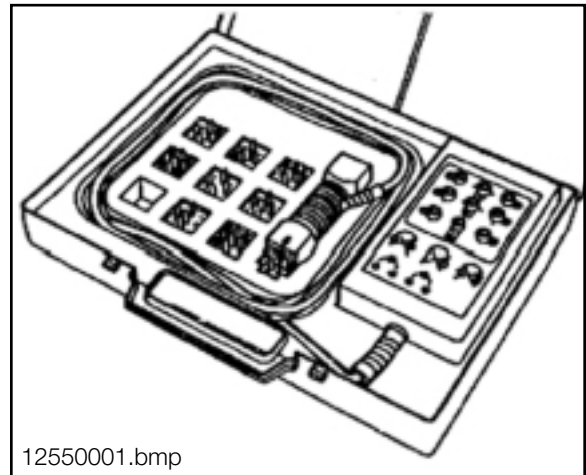

12550001.bmp

Air Management

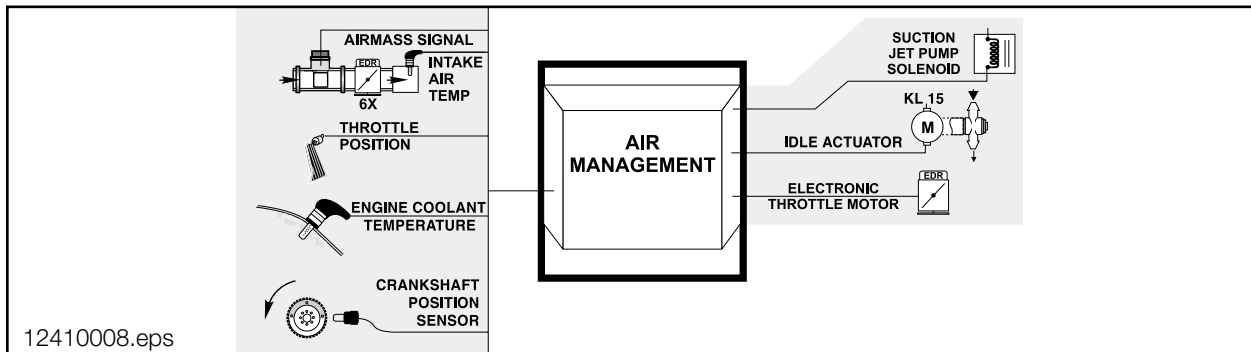

Throttle Valves: The mechanical throttle valves regulate the intake air flow and are operated by an Electronic Throttle Actuator (1 EDR).

The throttle valves are an assembly of six individual throttle housings linked by a common shaft. The throttle opening depends on engine rpm and load (1000 kg/h maximum air flow).

Refer to the Repair Instructions for throttle adjustments.

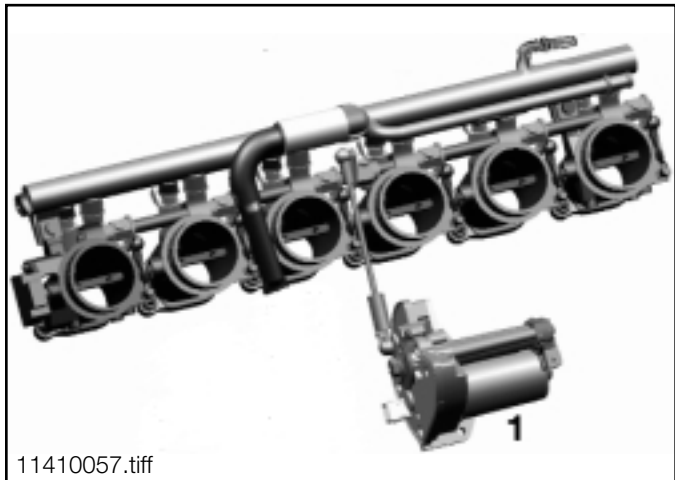

Accelerator Pedal Position (PWG):

The accelerator pedal module provides two variable voltage signals to the ECM that represents accelerator pedal position and rate of movement. The ECM will activate the EDR and Idle Air actuator based on the request.

Dual Hall Sensors are integral in the accelerator pedal module. The ECM compares the two values for plausibility.

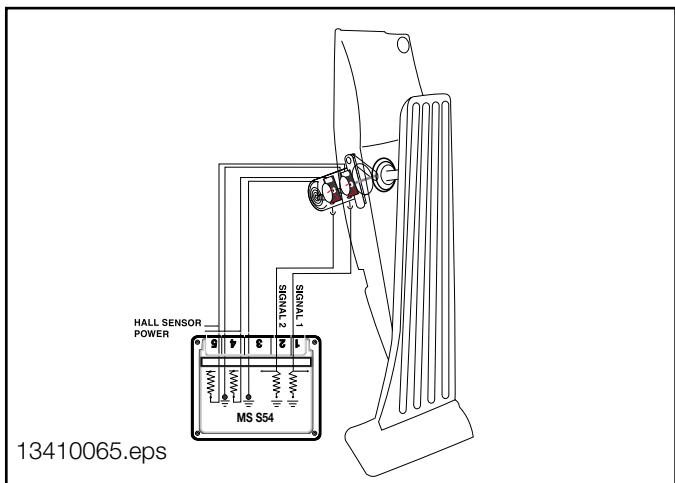

The ECM provides voltage (5v) and ground for the Hall sensors. As the accelerator pedal is moved from rest to full throttle, the sensors produce a variable voltage signal.

Hall sensor 1(request) = 0.5 to 4.5 volts
 Hall sensor 2 (plausibility) = 0.5 to 2.0 volts

If the signals are not plausible, the ECM will use the lower of the two signals as the request input. The throttle response will be slower and the maximum throttle response will be reduced.

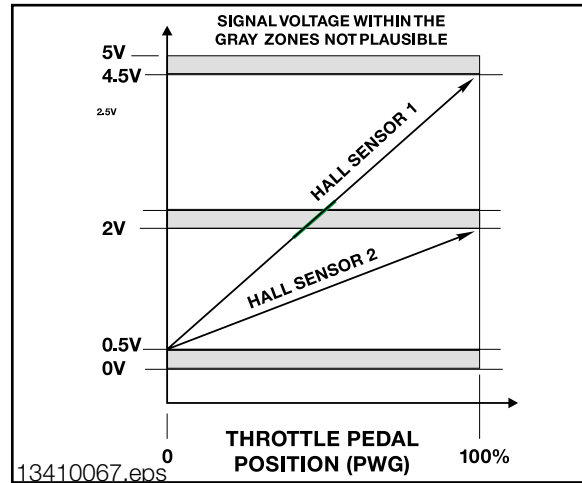

Electronic Throttle Actuator (EDR): The EDR is specifically designed for the S54 engine. This allows one actuator to operate all six throttles via a common linkage.

The ECM provides the operating voltage and ground to the EDR for opening and closing the throttles. The ECM monitors a feedback potentiometer located on the actuator shaft (arrow) for actuator position/plausibility (closed 4.5v - full open 0.5v).

There is a return spring fitted to the actuator lever end that assists in closing the throttles.

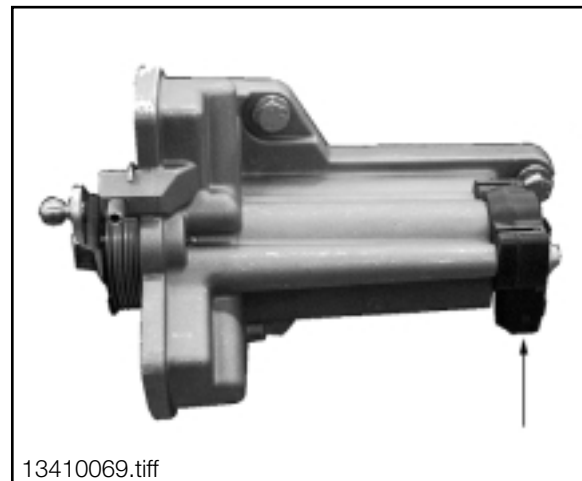

Throttle Valve Position: A potentiometer is fitted to the end of the throttle shaft (arrow) that allows the ECM to monitor throttle position.

This signal is used by the ECM for a position/plausibility check (closed 0.5v - full open 4.5v).

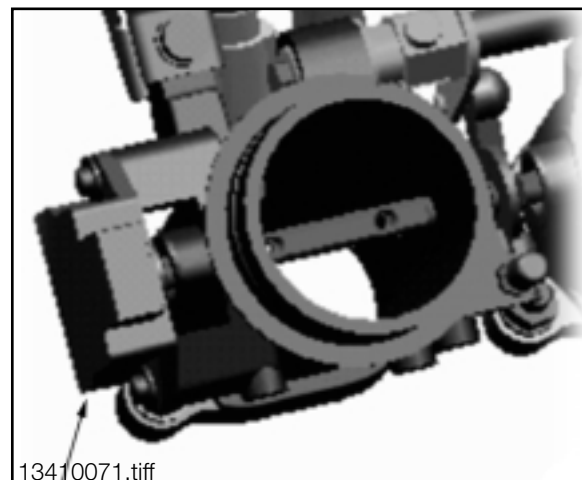

Idle Air Actuator: The Idle Air Actuator is a two-coil rotary actuator (ZWD5). The S54 features a second air supply system that functions independent of the throttle valve control system (EDR). This actuator regulates air by-passing the throttle valves to control low engine speed.

The valve is supplied with operating voltage from the ECM Relay. The ECM is equipped with two final stage transistors which will alternate positioning of the actuator.

The final stages are "pulsed" simultaneously by the ECM which provides ground paths for the actuator. The duty cycle of each circuit is varied to achieve the required idle RPM.

The maximum air flow of the idle air actuator (80 kg/h) permits emergency operation of the vehicle (limp-home mode).

The valve (2) regulates air flow through an external air distribution pipe to the individual throttle housings. The inducted air is shared between the idle actuator and throttle valves depending on the engine load.

Hot-Film Air Mass Meter (HFM): The air volume input signal is produced electronically by the HFM which uses a heated metal film in the air flow stream. The HFM is integral with the air filter upper housing (one-piece).

The ECM Relay provides the operating voltage. As air flows through the HFM, the film is cooled changing the resistance which affects current flow through the circuit. This also causes voltage drop across circuit as the resistance changes. The ECM monitors this change and regulates the amount of fuel injected.

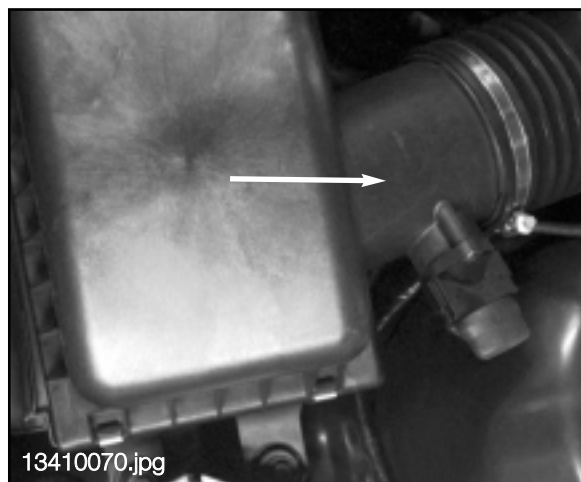
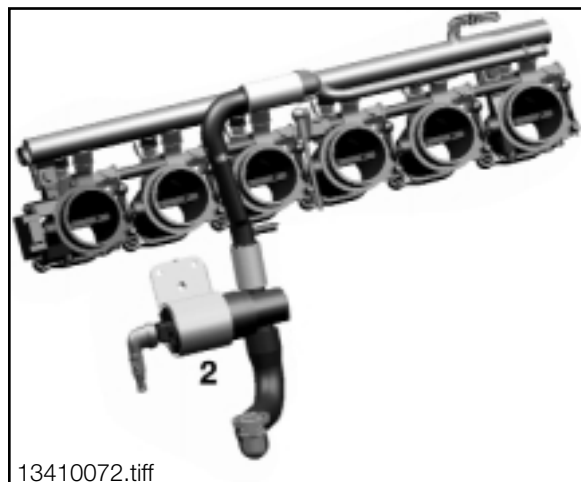
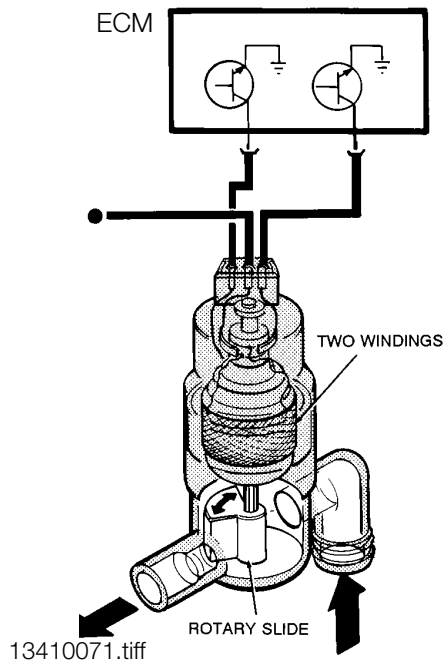

Air Temperature Signal: The HFM contains an integral air temperature sensor. This is a Negative Temperature Coefficient (NTC) type sensor. This signal is needed by the ECM to correct the air volume input for changes in the intake air temperature (air density) affecting the amount of fuel injected, ignition timing and Secondary Air Injection activation.

The ECM provides the power supply to this component. The sensor decreases in resistance as the temperature rises and vice versa. The ECM monitors an applied voltage to the sensor that will vary as air temperature changes the resistance value.

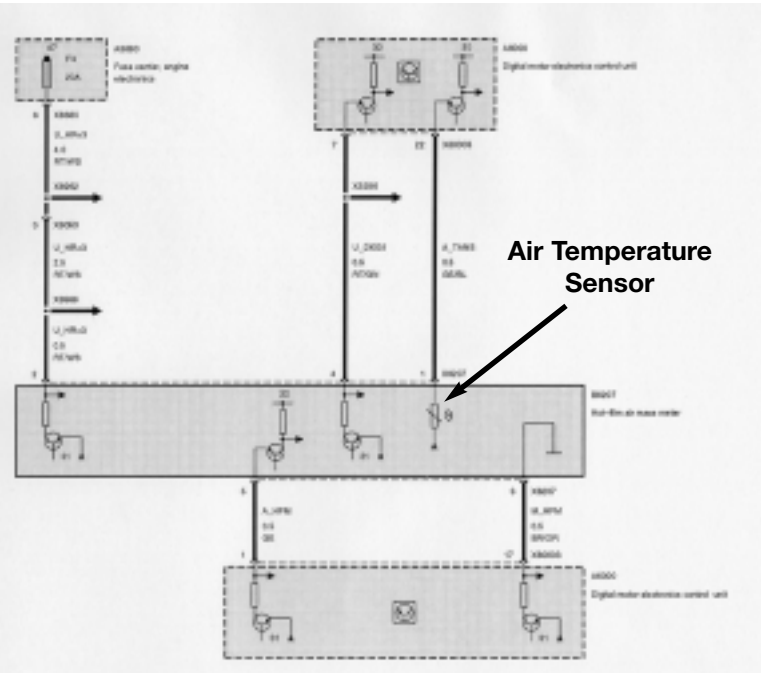

12410001.bmp

Suction Jet Pump: The ECM regulates the Suction Jet Pump (1) to provide sufficient vacuum for the brake booster under all operating conditions. The ECM controls the Suction Jet Pump Solenoid (2) to allow vacuum flow through.

Additional vacuum compensation is applied to the brake booster when the circuit is “deactivated” (solenoid sprung open).

Vacuum enhancement is limited to the brake booster when the control circuit is “activated” (solenoid powered closed).

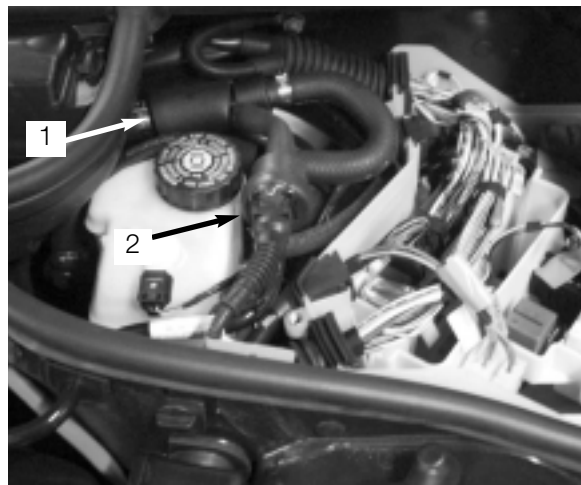

Principle of Operation

Air flow into the engine is regulated by the Throttle Valves and/or the Idle Air Actuator. Both of these air “passages” are necessary for smooth engine operation from idle to full load. On the MS S54 system, the Throttle Valve and the Idle Air Actuator are **electrically controlled**. All of the ECM monitoring, processing and output functions are a result of regulated air flow.

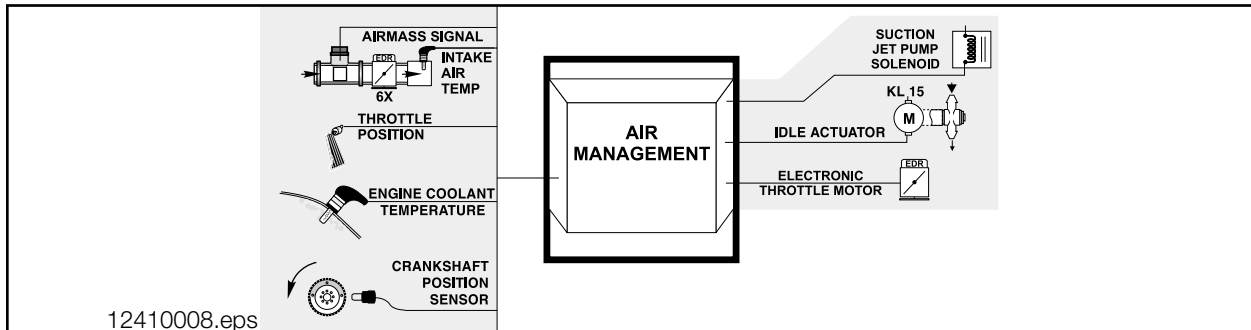

The Accelerator Pedal Position (PWG) is monitored by the ECM for pedal angle position and rate of movement. As the accelerator is moved, a rising voltage signal from the Hall sensors requests acceleration and at what rate. The ECM will increase the volume of fuel injected into the engine, advance the ignition timing and open the Throttle Valves and/or Idle Air Actuator. The “full throttle” position indicates maximum acceleration to the ECM, and in addition to the functions just mentioned, this will have an effect on the air conditioning compressor (covered in Performance Controls).

As the accelerator pedal is released (integral springs), a decrease in voltage signals the ECM to activate fuel shut off if the rpm is above idle speed (coasting). The Throttle Valves will be closed and Idle Air Actuator Valve will open to maintain idle speed.

The ECM monitors the engine idle speed in addition to the accelerator pedal position and throttle position voltage. If the voltage values have changed (mechanical wear of throttle plates or linkage), the ECM will adjust the Idle Air Actuator to maintain the correct idle speed.

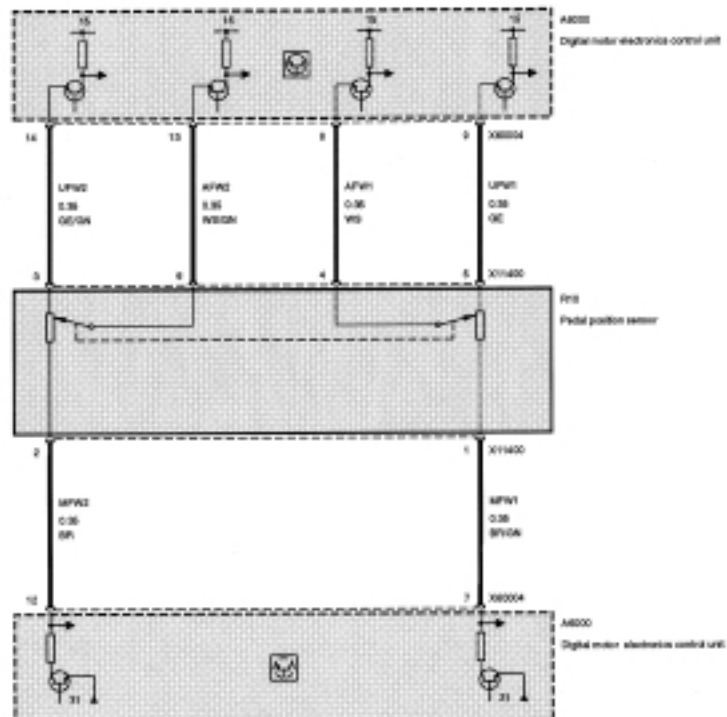

12410001.bmp

The pedal position sensor consists of two separate Hall sensors with different voltage characteristics and independent ground and voltage supply. Sensing of the accelerator pedal position is redundant. The pedal position sensor is monitored by checking each individual sensor channel and comparing the two pedal values. Monitoring is active as soon as the sensors receive their voltage supply (KL15). The ECM decides what operating mode the pedal position sensor is to assume.

Mode 0 = Pedal position sensor fully operable

Mode 1 = Failure of one pedal position sensor (maximum engine speed is limited)

Mode 2 = Failure of both pedal position sensors (engine speed limited to 1500 rpm)

The Idle Air Actuator is controlled by the ECM modulating the ground signals (PWM at 100 Hz) to the valve. By varying the duty cycle applied to the windings, the valve can be progressively opened, or held steady to maintain the idle speed. The ECM controls the Idle Air Actuator to supply the necessary air to maintain idle speed. When acceleration is requested and the engine load is low (<15%), the actuator will also supply the required air.

There are additional factors that influence the ECM in regulating idle speed:

- The RPM sensor input allows the ECM to monitor engine speed because of loads that cause idle fluctuations due to drag on the engine: power steering, thick oil (frictional forces), etc.
- Cold engine temperature (coolant NTC) provides higher idle speed to raise temperature sooner.
- Vehicle speed informs ECM when the vehicle is stationary and requires idle maintenance.
- A/C on request from the climate control system (arming the ECM) and compressor engage (stabilize idle speed) acknowledgment.

The Electronic Throttle Actuator (EDR) is operated by the ECM for opening and closing based on the accelerator pedal position, DSC intervention and cruise control functions. For exclusive control, the ECM supplies the voltage and ground for operation. The system requires approx. 110 milliseconds in order to fully open the closed throttle valves.

When the EDR is operated, the ECM monitors a feedback potentiometer located on the actuator shaft for position/plausibility. As the EDR opens the Throttle Valves to accelerate the engine, the position is also monitored by a feedback potentiometer located on the end of the throttle shaft on the number 1 throttle housing. These two sensors operate inverse-ly (voltage values) with throttle actuation.

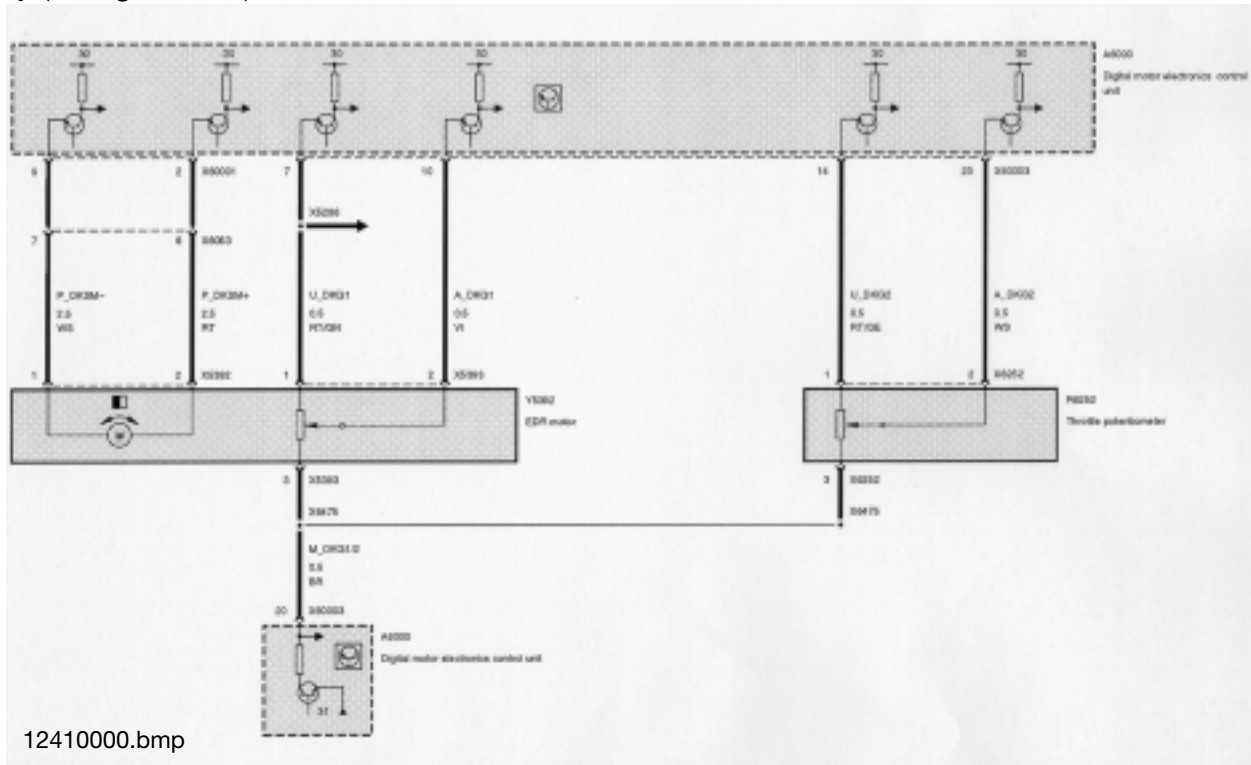

The EDR actuator will “open” the throttle valves for acceleration when the engine load is >15%. There is a transition during acceleration when the Idle Air Actuator will also be open providing additional air for initial acceleration torque.

With the Idle Actuator System and Electronic Throttle Control (EDR), the S54 is equipped with two independent air systems. The ECM is therefore capable of dividing the air volume of the engine between the idle actuator and/or throttle valves corresponding to the load status.

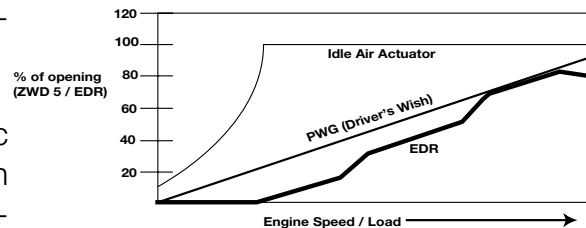

00410010.eps

Pre-drive Check

The pre-drive check has following tasks:

- Zero point adaptation of the throttle potentiometers.
- Checking freedom of movement of the throttle valves and electronic accelerator pedal control circuit.
- Checking the safety cutout and the return springs of the electronic accelerator pedal and throttle valves.

This check is conducted every time KL15 is activated. The full load adaptation stop is learned in a new ECM the first time KL15 is recognized.

The pre-drive check is conducted in 3 phases:

- Phase 1: The throttle valves are closed by the EDR actuator. The position of the throttle potentiometer on the EDR is determined.
- Phase 2: The throttle valves are opened 3% by the EDR actuator. The position of the throttle potentiometer on the throttle valve shaft is determined.
- Phase 3: The throttle valves are opened by approx. 20%. The EDR actuator is switched off. The throttle valves are closed by spring force (a mechanical clicking sound can be heard while the throttle valves are closing).

Post Drive Check

- Post Drive Check: 10 seconds after KL15 is switched "OFF" the EDR actuator is opened 102% in order to carry out renewed full load adaptation. Adaptation during the post drive check is only carried out when the engine is turned off before reaching the operating temperature.

EDR Safety Concept - Emergency Running Programs

The safety concept of the throttle valve control system achieves a slow transition to an emergency running (limp-home) program that can still be managed by the driver.

A basic differentiation is made between PWG emergency operation with a PWG sensor and PWG emergency operation without a PWG sensor. There is a total of 4 emergency operation (limp-home) program stages.

In the event of a PWG sensor failing, the system switches to a PWG emergency operation characteristic curve with lower setpoints. "Engine Emergency Program" is indicated to the driver by the EML warning lamp in the instrument cluster.

Stage 1 (Emergency Operation with a Throttle Position Sensor)

The emergency program stage 1 includes limiting the torque and the EDR setpoint. Based on the current engine torque, the maximum torque is limited in the emergency operation stage. The EDR actuator is limited by reducing the pulse duty factor. The plausibility of the throttle position sensors are checked based on the load signal from the hot-film air mass meter. The measured air mass must not exceed a defined limit. This limit is above the value that can be achieved with the idle air actuator.

Stage 2 (Emergency Operation via Idle Air Actuator)

The transition to emergency program stage 2 greatly depends on the type of fault. For example, if there is a defect in EDR actuator operation, the throttle valves are sprung closed without ECM influence.

In the event of implausible signals from the throttle position Hall sensors 1 and 2, immediate deactivation of the EDR actuator may be necessary under certain circumstances.

In cases where feedback of the actual position is still available and the set position can still be controlled, the ECM closes the throttle valves. The EDR actuator is then switched off and engine speed and road speed limitation activated.

Stage 3 (Emergency Operation with Open Throttle Valves)

The stage 3 emergency operation program is activated when the actual throttle position exceeds the set throttle position for a defined period of time despite power being applied to the EDR actuator, the throttle valves cannot be closed. The ECM reduces the amount of fuel injected (fade out) and retards the ignition timing to limit engine torque. If it is necessary to further reduce the torque, individual fuel injectors are deactivated one cylinder at the time.

Stage 4 (Emergency Operation with Internal ECM Fault)

The stage 4 emergency operation program is always activated when an internal ECM fault is detected. In this case, the characteristics of the throttle valve control (EDR) are not predictable, therefore the ECM reduces the amount of fuel injected (fade out) and retards the ignition timing to limit engine torque. If it is necessary to further reduce the torque, individual fuel injectors are deactivated one cylinder at the time.

Emergency Operation Functions

Engine torque limitation In the emergency programs stage 1 - 4 is restricted to a value specified by the emergency operation (limp-home) program.

Stage	Engine Speed RPM	Road Speed km/h	Torque Nm
1	7600 rpm	240 km/h	320 Nm
2	4000 rpm	80 Km/H	250 Nm
3	2750 rpm	50 km/h	200 Nm
4	2750 rpm	50 km/h	200 Nm

00410009.eps

In the relevant emergency programs, the MS S54 limits the engine characteristics to the values indicated in the table. In emergency programs 3 and 4, in addition to the engine emergency program being indicated in the instrument cluster (EML), **all warning elements in the tachometer are activated.**

The Hot-Film Air Mass Meter (HFM) varies voltage monitored by the ECM representing the measured amount of intake air volume. This input is used by the ECM to determine the amount of fuel to be injected.

The heated surface of the hot-film in the intake air stream is regulated by the ECM to a constant temperature of 180° above ambient air temperature. The incoming air cools the film and the ECM monitors the changing resistance which affects current flow through the circuit. The hot-film does not require a “clean burn”, it is self cleaning due to the high operating temperature for normal operation.

If this input is defective, a fault code will be set and the “ENGINE EMISSION” Light will illuminate. The ECM will maintain engine operation based on the Throttle Position Sensors and Crankshaft Position/Engine Speed Sensor.

The Air Temperature signal allows the ECM to make a calculation of air density. The varying voltage input from the NTC sensor indicates the larger proportion of oxygen found in cold air, as compared to less oxygen found in warmer air. The ECM will adjust the amount of injected fuel because the quality of combustion depends on oxygen sensing ratio.

The ignition timing is also affected by air temperature. If the intake air is hot the ECM retards the base ignition timing to reduce the risk of detonation. If the intake air is cooler, the base ignition timing will be advanced. The ECM uses this input as a determining factor for Secondary Air Injection activation (covered in the Emissions section).

The Suction Jet Pump is regulated by the ECM to provide sufficient vacuum for the brake booster under all operating conditions. The ECM controls the Suction Jet Pump Solenoid to allow vacuum flow through.

The additional vacuum compensation is activated by the ECM when the idle air actuator is regulated for:

- A/C compressor “on”
- Vehicle in gear and the clutch is released (driving under load)
- Engine in warm-up phase <70° C

Additional vacuum compensation is applied to the brake booster when the circuit is “deactivated” (Solenoid sprung open).

Vacuum enhancement is limited to the brake booster when the control circuit is “activated” (Solenoid powered closed).

Workshop Hints

Air Management

Unmetered air leaks can be misleading when diagnosing faults causing “ENGINE EMISSION” Light/driveability complaints. Refer to S.I. # 11 03 92 (3500) for testing intake vacuum leaks.

Crankcase Ventilation System

A fault in this system can often “mislead” diagnosis. This type of fault can produce:

- Mixture/misfire defect codes
- Whistling noises
- Performance/driveability complaints

Please refer to the following Service Information Bulletins for details on the **Crankcase Ventilation System**:

- Crankcase Ventilation System Check S.I. #11 05 98

Throttle Position Sensors - Testing

The Throttle Position Sensors (potentiometers) can be tested with the following methods:

- DIS Status Page (approx. 0.5v to 4.5v)
- DIS Oscilloscope - Select from the Preset Measurements which requires taking the measurement with the ECM and Universal Adapter connected to the circuit (as shown on the right).
- Resistance check of the entire circuit, using the Universal Adapter with the ECM disconnected.

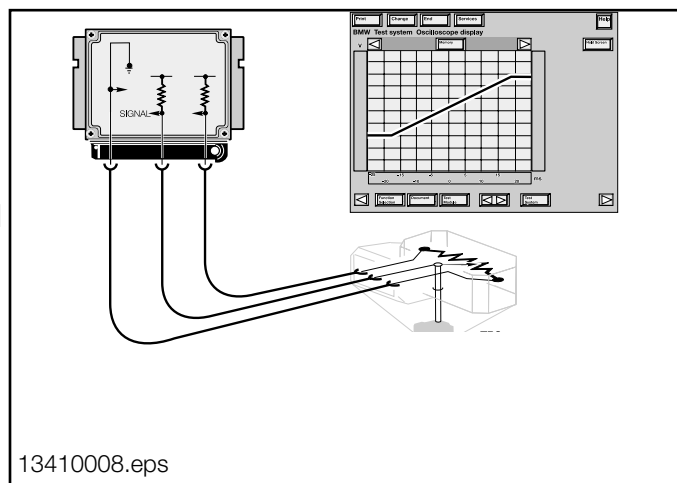

Idle Air Actuator - Testing

- The Idle Air Actuator and idle air circuit (passage ways) should be checked for physical obstructions.
- The resistance of the valve winding should be checked.
- The ECM output and Idle Speed Control Valve operation can be tested by "Component Activation" on the DIS/MoDIC.
- The Pulse Width Modulated ground output from the ECM can be tested using the DIS/MoDIC Oscilloscope.
- Consult Technical Data for specified idle speed.

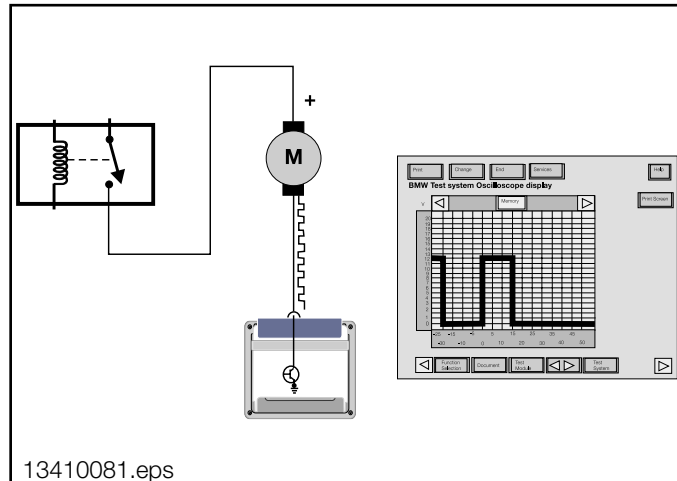

Tools and Equipment

The DIS/Modic as well as a reputable hand held multimeter can be used when testing inputs/components.

It is best to make the checks at the ECM connection, this method includes testing the wiring harness.

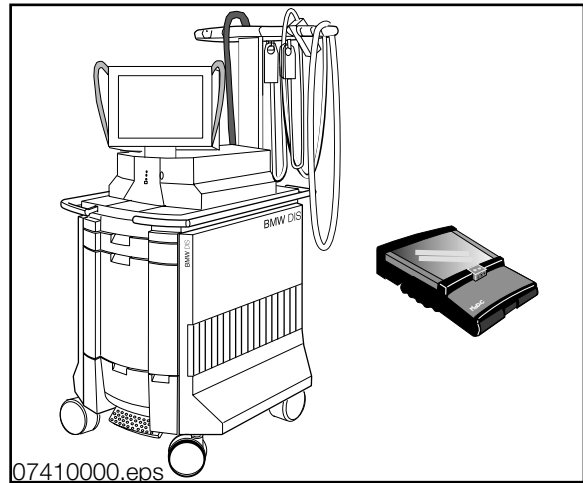

The correct Universal Adapter for the MS S54 application should be used (#90 88 6 121 300). This will ensure the pin connectors and the harness will not be damaged.

When installing the Universal Adapter to the ECM (located in the Electronics Box in the engine compartment), make sure the ignition is switched off.

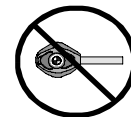
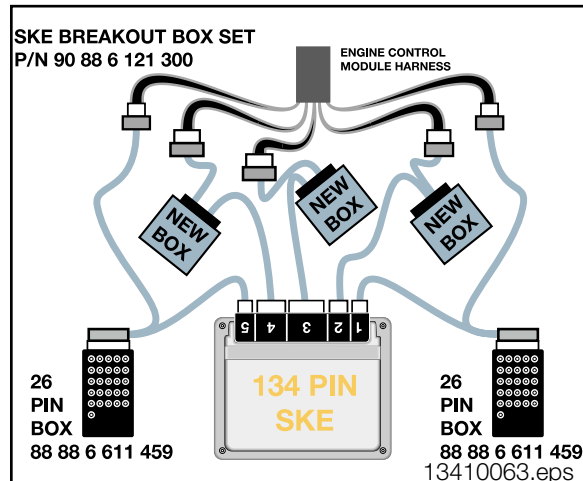

The Slack Tube Manometer Test Tool (#99 00 0 001 410) should be used to troubleshoot crankcase ventilation valves.

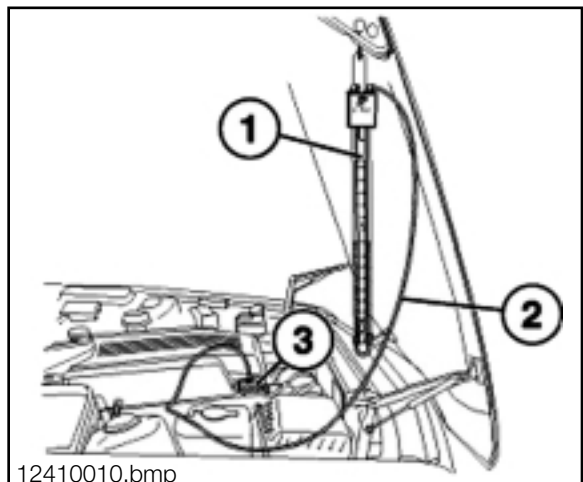

Fuel Management

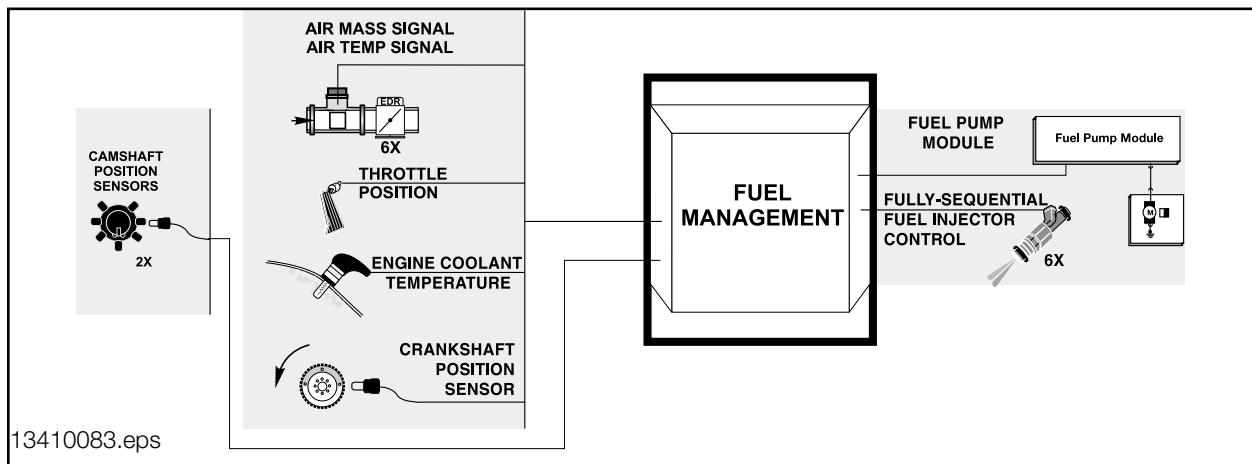

Fuel Tank: The fuel tank is made of high density polyethylene (reduced weight) which is manufactured to meet safety requirements.

The baffling has been modified for the E46 M3 fuel pump pickup in the right hand side of the fuel tank to maintain fuel supply during aggressive cornering.

A “saddle” type tank is used which provides a tunnel for the driveshaft but creates two separate low spots in the tank.

A Syphon jet is required with this type of tank to transfer fuel from the left side of tank to transfer fuel from the left side, linked to the fuel return line.

As fuel moves through the return, the syphon jet creates a low pressure (suction) to pick up fuel from the left side of the tank and transfer it to the right side at the fuel pick up.

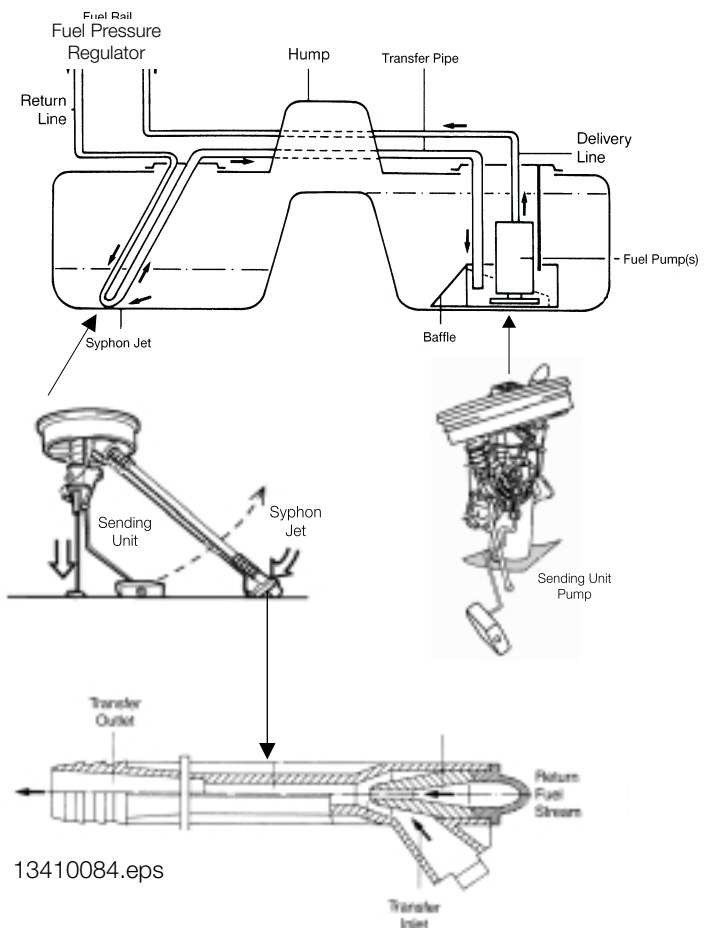

Fuel Pump: The electric fuel pump supplies constant fuel volume to the injection system. This system uses a single submersible (in the fuel tank) high volume pump. The inlet is protected by a mesh screen.

When the fuel pump is powered, the armature will rotate the impeller disc creating low pressure at the inlet. The fuel will be drawn into the inlet and passed through the fuel pump housing (around the armature). The fuel lubricates and cools the internals of the pump motor.

The fuel will exit through a non-return check valve to supply the injection system. The non-return check valve is opened by fuel exiting the pump and will close when the pump is deactivated. This maintains a “prime” of fuel in the filter, lines, hoses and fuel rail.

The pump contains an internal overpressure relief valve that will open (reducing roller cell pressure) if there is a restriction in the fuel supply hardware.

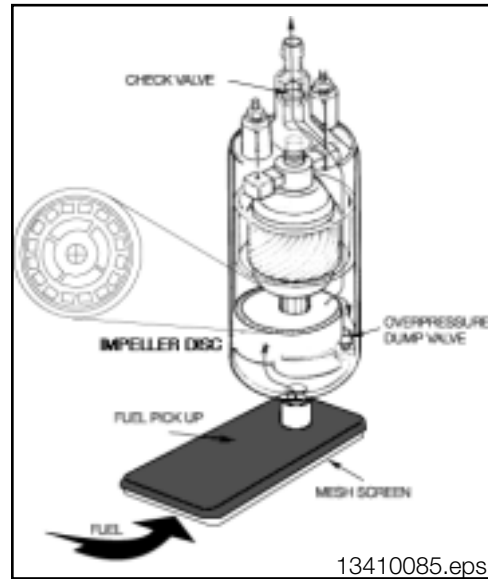

Fuel Supply: The fuel is supplied through a Non Return Fuel Rail System. This system is used on the S54 for LEV compliancy.

The fuel supply pressure is controlled by the 5 Bar fuel pressure regulator integrated in the fuel filter assembly. The regulator is influenced by engine vacuum via a hose connected to the idle air distribution pipe. The fuel exits the fuel pressure regulator supplying the fuel rail and the injectors. The fuel filter assembly is located under the left front floor area (next to the frame rail).

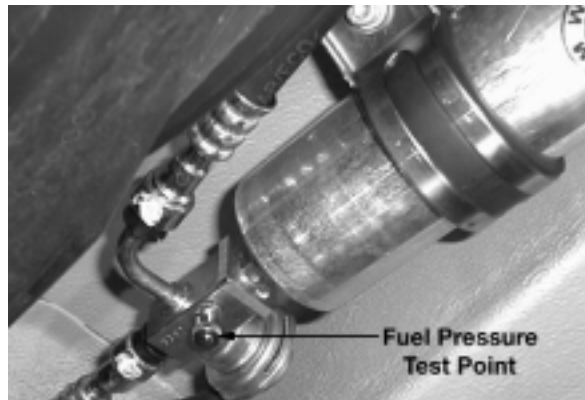

The fuel return line is located on the filter/regulator assembly which directs the unused fuel back to the fuel tank. The fuel tank hydrocarbons are reduced by returning the fuel from this point instead of from the fuel rail.



Fuel Pressure Regulator: The Fuel Pressure Regulator maintains a constant “pressure differential” for the fuel injectors.

The fuel pressure is set to 5.0 Bar (+/- 0.2) by internal spring tension on the restriction valve.

The vacuum chamber is sealed off by a diaphragm which is connected by a hose to the idle air distribution pipe (vacuum). Intake manifold vacuum regulates the fuel pressure by assisting to compress the spring (lowering fuel pressure).

When the restriction valve opens, unused fuel returns back to the fuel tank.

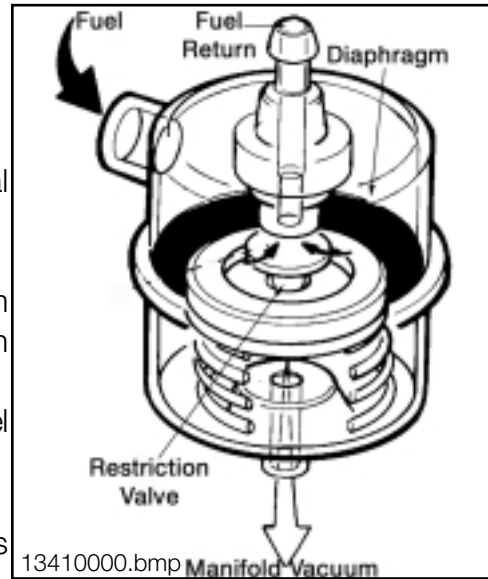

Examples of “pressure differential” are:

- At low to part throttle, intake manifold vacuum is available at the tip of the fuel injectors to enhance fuel “flow through”. Vacuum is also applied to the fuel pressure regulator vacuum chamber, causing the diaphragm to compress the spring which opens the restriction valve. This lowers the fuel pressure available to the fuel injectors.

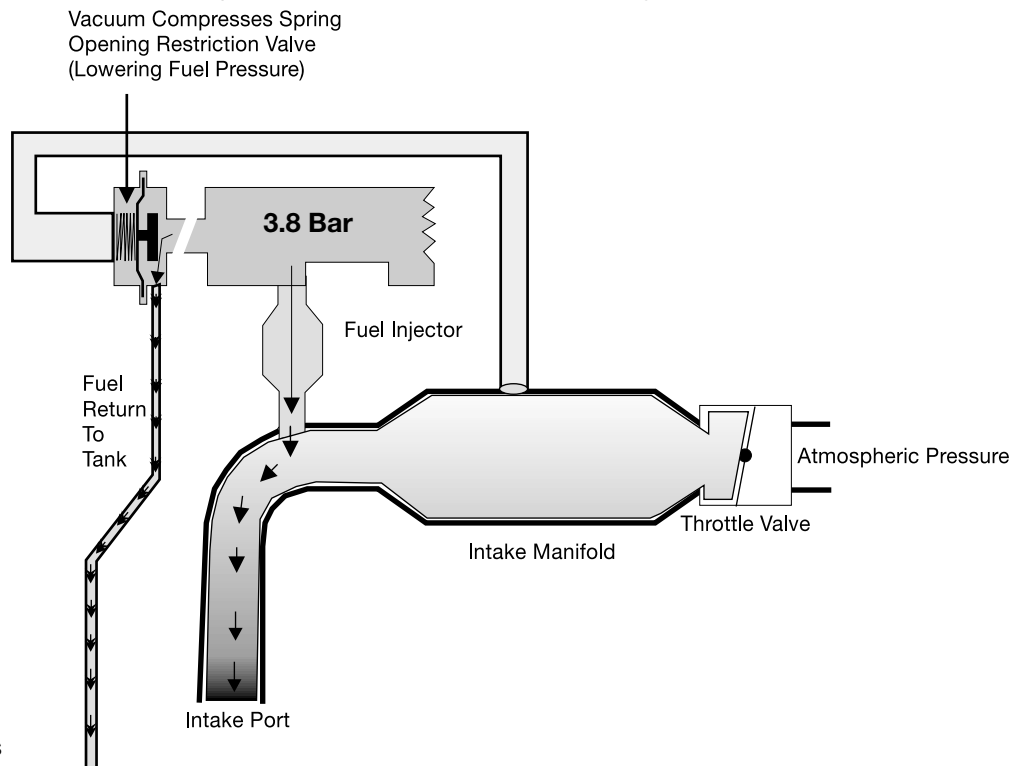

- Wide open throttle depletes intake manifold vacuum at the tip of the fuel injectors and in the fuel pressure regulator vacuum chamber. The spring closes the restriction valve to raise fuel pressure available to the fuel injectors. This maintains pressure differential (fuel flow through) for the fuel injectors.

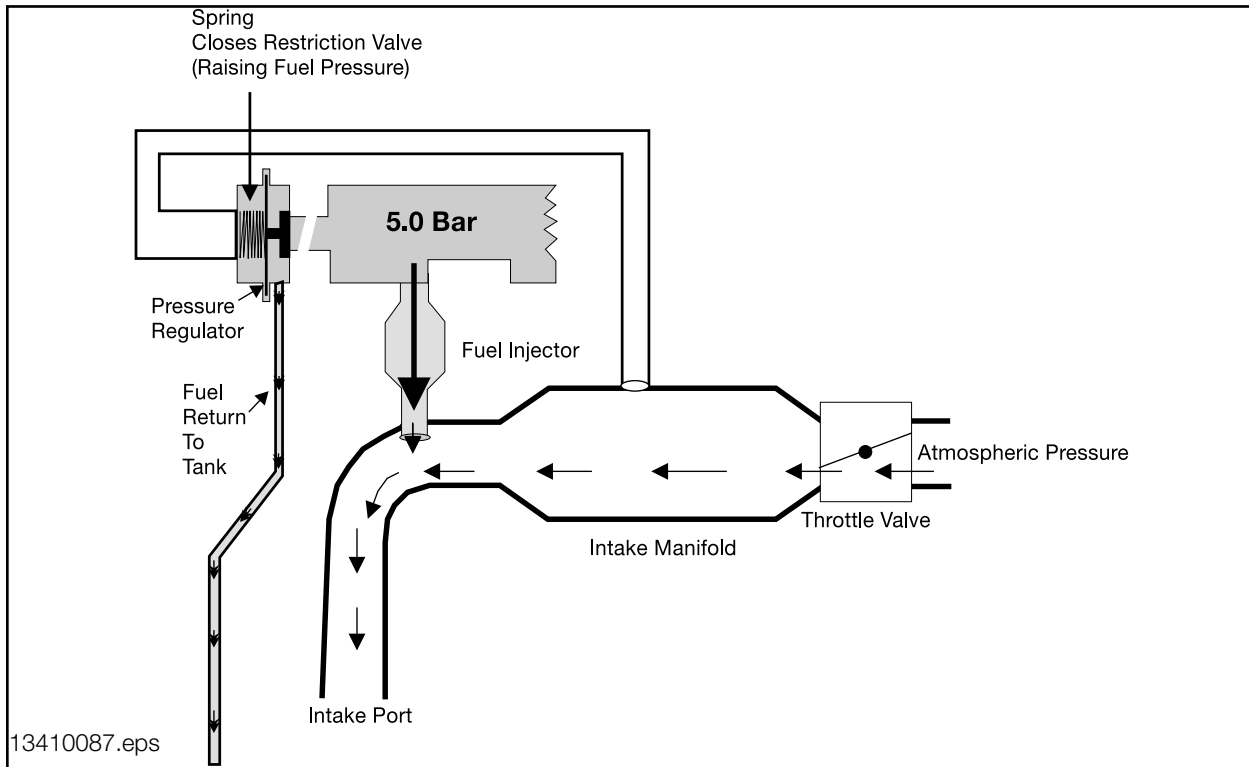

By maintaining constant Fuel Pressure Differential through vacuum sensing (engine load), the ECM can then regulate volume and mixture by the length of time the injectors are open (duration).

The Fuel Pressure Regulator is mounted on the fuel filter assembly.

- | | |
|-----------|--------------------------------------|
| 1. | Vacuum Hose |
| 2. | Retaining Ring |
| 3. | 5 Bar Fuel Pressure Regulator |

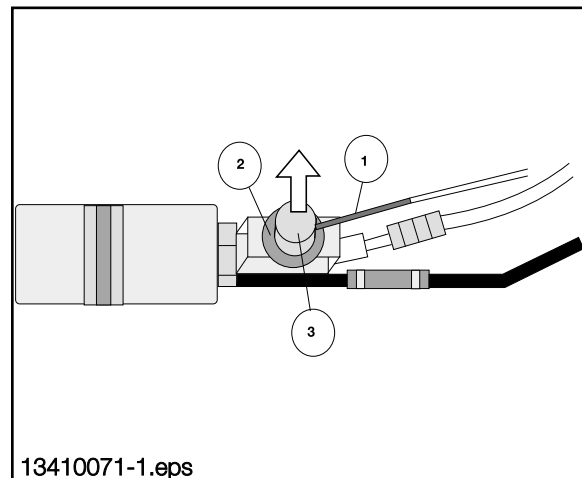

Bosch Fuel Injectors (4 Hole Plate Type): The Fuel Injectors are electronically controlled solenoid valves that provide precisely metered and atomized fuel into the engine intake ports. The Fuel Injector Valve consists of:

1.	Fuel Strainer
2.	Electronic Connector
3.	Solenoid Winding
4.	Closing Spring
5.	Plate Valve
6.	Outlet Oriface
7.	4 Hole Channeling

Fuel is supplied from the fuel rail to the injector body. The fuel is channeled through the injector body to the plate valve and seat.

Without electrical current, the plate valve is sprung closed against the seat.

The Fuel Injectors receive voltage from the Fuel Injector Relay. The ECM activates current flow through the injector solenoid creating a magnetic field that pulls the plate valve “up” off of its seat.

The pressurized fuel flows through the outlet orifice into the channeling. The channel “fans out” the fuel spray into four angled spray patterns which helps to atomize the fuel.

When the ECM deactivates current flow, the plate valve is sprung closed against the seat and fuel flow through the injector is stopped.

The length of time that the ECM activates the injectors is very brief, the duration is in milli-seconds (ms). This affects the amount of fuel volume flowing through the Fuel Injectors. The ECM will vary the length of time (ms) to regulate the air/fuel ratio (mixture).

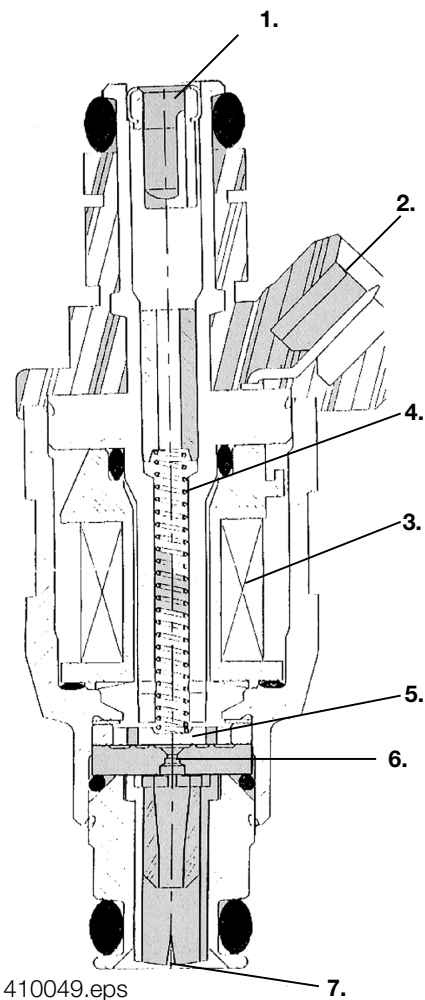

11410049.eps

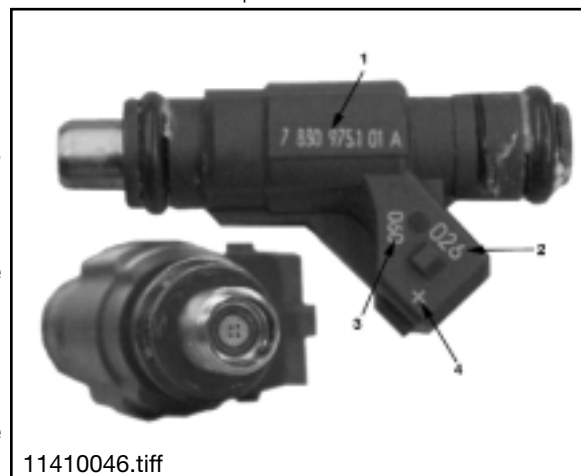

11410046.tiff

1.	BMW Number
2.	Fuel Injector Code
3.	Mfg Date (week 06 year 2000)
4.	B+ Voltage Connection

The Fuel Injectors are mounted in rubber “o-rings” between the fuel rail and the intake manifold to insulate them from heat and vibration.

This insulation also reduces the injector noise from being transmitted through the engine compartment.

The Fuel Injectors are held to the fuel rail by securing clips (arrow).

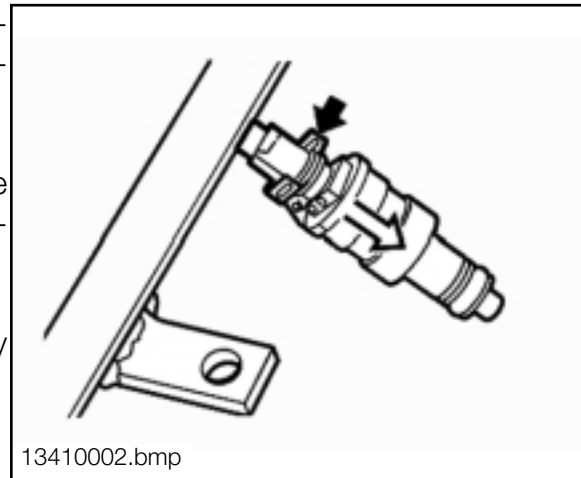

If a Fuel Injector is faulty (mechanical/electrical), it can produce the following complaints:

1.	“Engine EMISSION” Light	4.	Excessive Tailpipe Smoke (leaking)
2.	Long Crank Time (Leaking)	5.	Misfire/Rough Idle (leaking/blocked)
3.	Oxygen Sensor/Mixture/Injector Related Fault Codes	6.	Engine Hydrolock (leaking)

Crankshaft Position/RPM Sensor: This sensor provides the crankshaft position and engine speed (RPM) signal to the ECM for Fuel Pump and Injector operation. This is an inductive pulse type sensor mounted on the left side at the rear of the engine block. The impulse wheel is mounted on the crankshaft inside the crankcase, at the rear main bearing support. The impulse wheel contains 58 teeth with a gap of two missing teeth. The ECM provides the power supply to this component.

The rotation of the impulse wheel generates an A/C voltage signal in the sensor where-by each tooth of the wheel produces one pulse. The ECM counts the pulses and determines engine rpm.

The gap of two missing teeth provides a reference point that the ECM recognizes as crankshaft position.

The crankshaft position sensor is monitored as part of OBD II requirements for Misfire Detection.

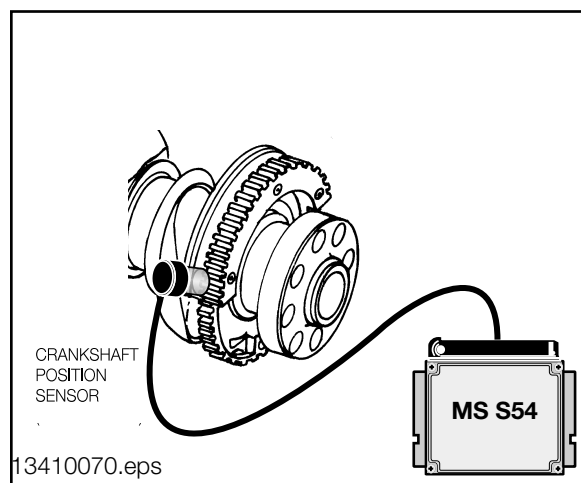

Camshaft Position Sensors (Hall Effect): The ECM uses the signal from the camshaft sensors to set up the triggering of the ignition coils, correct timing of fully sequential fuel injection, and VANOS operation. The ECM Relay supplies voltage to the Hall elements and the ECM supplies the ground. The power flow through the Hall elements is the basis for the sensor output to the ECM.

As the camshaft rotates, the leading edge of the impulse wheel approaches the sensor tip creating a magnetic field with the permanent magnet in the sensor.

The attraction causes the magnetic field to penetrate through the Hall element. The magnetic field affects the power flow in the element causing the input signal to go high. As the impulse wheel passes by the sensor, the signal goes low.

The repetitive high/low creates a square wave signal that the ECM uses to recognize the camshaft position.

The “active” Hall sensors supply a signal representative of camshaft position even before the engine is running. The ECM determines an approximate location of the camshaft position (high or low signal) prior to engine start up optimizing cold start injection (reduced emissions).

An impulse wheel is mounted on the end of each camshaft for position detection. The intake camshaft impulse wheel has 6 lugs and the exhaust camshaft impulse wheel has 7 lugs. The sensors are mounted on each side at the back of the cylinder head.

If the ECM detects a fault with this type of sensor (shown on the right), the “ENGINE EMISSION” Light will be illuminated and the system will maintain engine operation based on the Crankshaft Position/RPM Sensor. Torque reduction will be noticed due to “default” VANOS position.

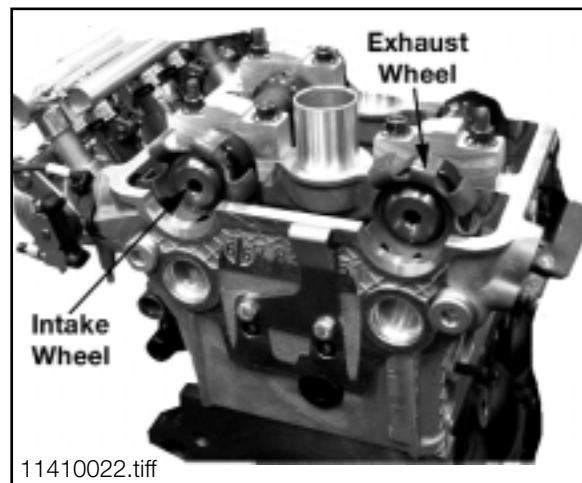
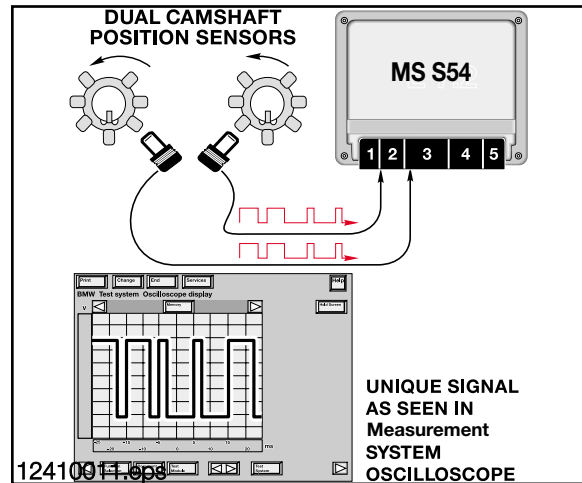

Engine Coolant Temperature: The Engine Coolant Temperature is provided to the ECM from a Negative Temperature Coefficient (NTC) type sensor. The ECM determines the correct fuel mixture and base ignition timing required for the engine temperature.

The dual sensor (ECM/Temp Gage) is located in the coolant return pipe (arrow).

The sensor decreases in resistance as the temperature rises and vice versa. The ECM monitors an applied voltage to the sensor (5v). This voltage will vary (0-5v) as coolant temperature changes the resistance value.

If the Coolant Temperature Sensor input is faulty, the “ENGINE EMISSION” Light will be illuminated and the ECM will use the oil temperature sensor as an alternate.

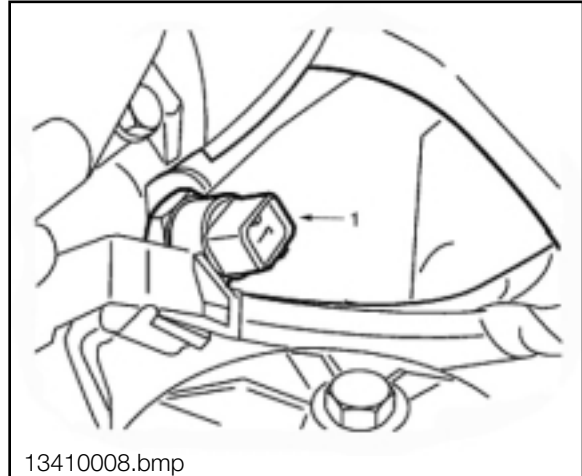

Accelerator Pedal Position (PWG):

As the accelerator pedal is actuated, the ECM will increase the volume of fuel injected into the engine. As the accelerator pedal is released, the ECM activates fuel shut off if the rpm is above idle speed (coasting).

For details about the sensor, refer to the Air Management section.

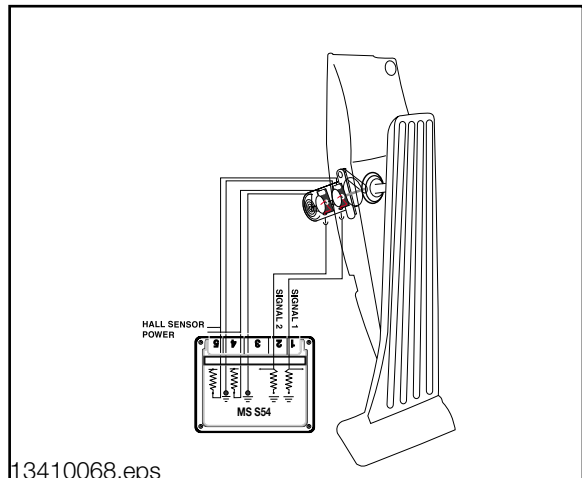

Hot-Film Air Mass Meter (HFM): The air volume input signal is used by the ECM to determine the amount of fuel to be injected for correct air/fuel ratio.

For details about the sensor, refer to the Air Management section.

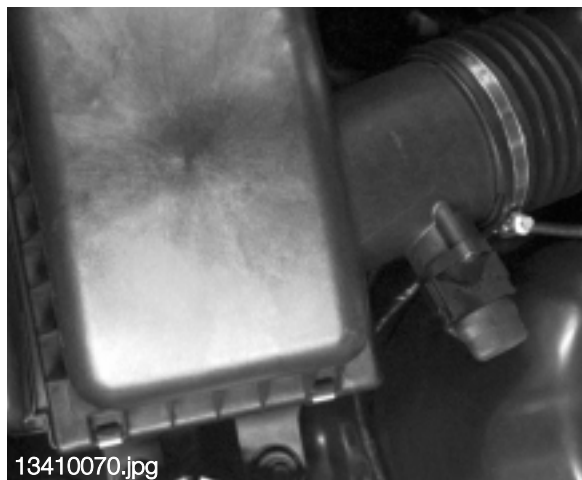

Air Temperature: This signal allows the ECM to make a calculation of air density. For details about the sensor, refer to the Air Management section.

The varying voltage input from the NTC sensor indicates the larger proportion of oxygen found in cold air, as compared to less oxygen found in warmer air. The ECM will adjust the amount of injected fuel because the quality of combustion depends on oxygen sensing ratio.

If a fault is present in this circuit, the ECM will operate on a substitute value.

Principle of Operation

Fuel Management delivers fuel from the tank to the intake ports of the engine. To accomplish this, **fuel supply** must be available to the fuel injectors. Then the fuel must be **injected** in the precise amount and at the correct time. The ECM does not directly monitor fuel supply, although it does control it. The ECM controls and monitors fuel injection.

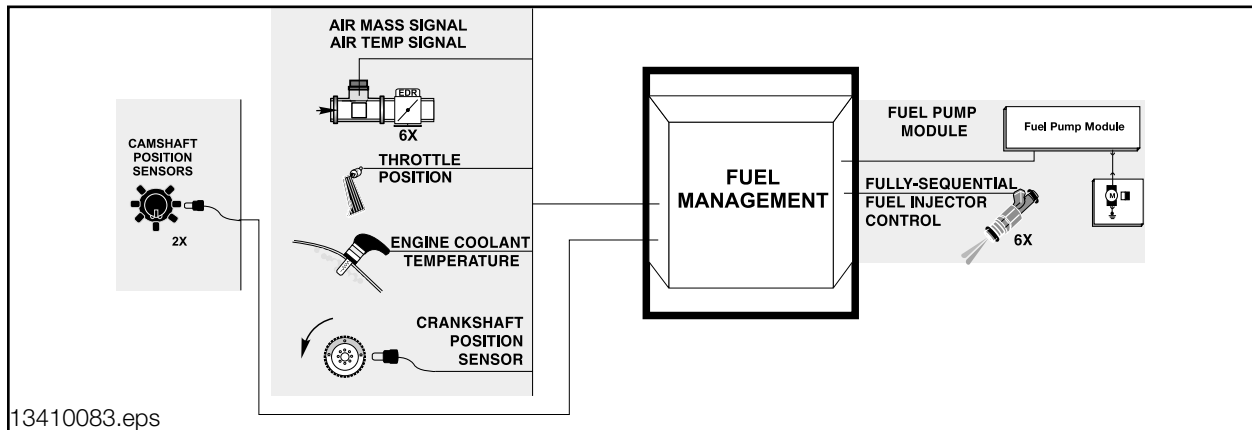

The **Fuel Pump** supplies fuel when it receives operating voltage from the Fuel Pump Module. The ECM Relay supplies voltage to the Fuel Pump Module (located in the trunk, above right wheel well).

The ECM controls the activation of the fuel pump module. After the ignition is switched ON, the ECM provides voltage for the fuel pump module and the voltage is maintained (pulse width modulated) with the presence of the engine speed signal.

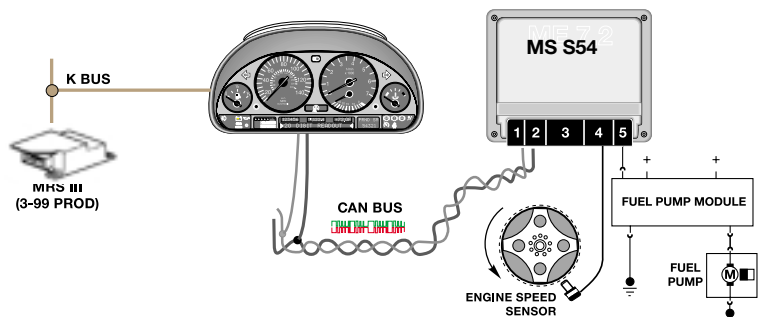

A new fuel pump is utilized to match the fuel supply demands of the S54 engine (5 Bar). The ECM will cycle the voltage signal (0 - 120 Hz) to the fuel pump module. The fuel pump module will cycle the voltage to the pump (to reduce the speed). The fuel pump will operate at low speed during idle and part load. The pump will run at full speed during start-up (approx. 20 seconds) and full load.

The power to the fuel pump relay will be switched off in the event of an airbag activation. The MRS III control module will signal the Engine control module over K-bus and CAN bus for this purpose.

The Fuel Injectors will be opened by the ECM to inject pressurized fuel into the intake ports. The ECM Relay supplies voltage to the Fuel Injector Relay, the Fuel Injector Relay supplies operating voltage to the injectors. The ECM controls the opening by activating the ground circuit for the Solenoid Windings. The ECM will vary the duration (in milli-seconds) of “opening” time to regulate the air/fuel ratio.

The ECM has a Final Stage output transistor for each injector that switches ground to the injector solenoids. The Injector “triggering” is first established from the Crankshaft Position/RPM Sensor when KL15 is “on”.

The ECM is programmed to activate the Final Stage output transistors once (per cylinder) for every working cycle of the engine (Full Sequential Injection). The ECM calculates the total milli-second time to open the injectors and triggers them independently.

During start up, the ECM recognizes the Camshaft Position (Cylinder ID) inputs. The camshaft positions are referenced to the crankshaft position. This process “times” the injection closer to the intake valve opening (working cycle) for increased efficiency.

When activated, each injector delivers the full fuel charge at separate times for each cylinder working cycle.

The Camshaft Position input is monitored by the ECM during start up. There will be an effect on injector timing if this input is missing when the engine is started.

When KL15 is switched “off”, the ECM discontinues voltage to the Fuel Injector Relay and deactivates the Final Stage transistors to cease fuel injection.

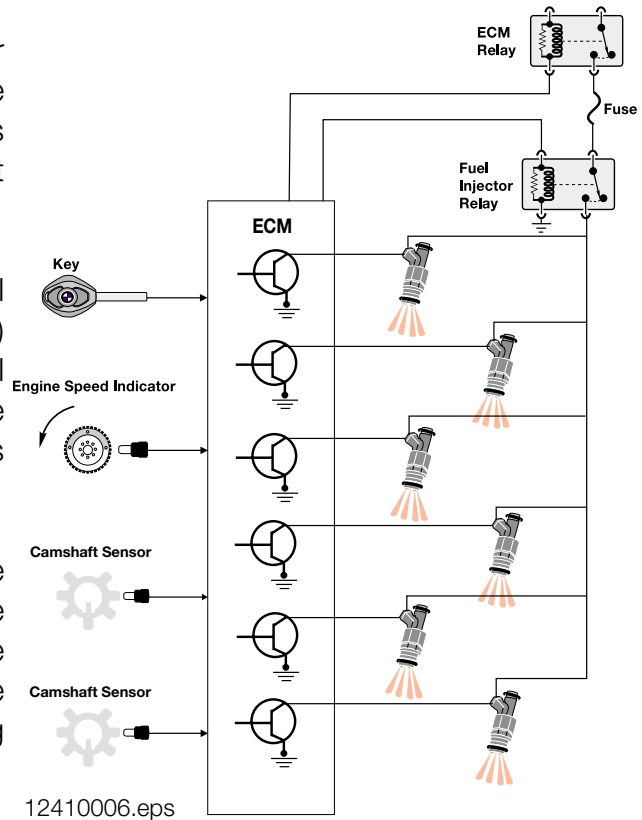

12410006.eps

Full Sequential Injection Timing

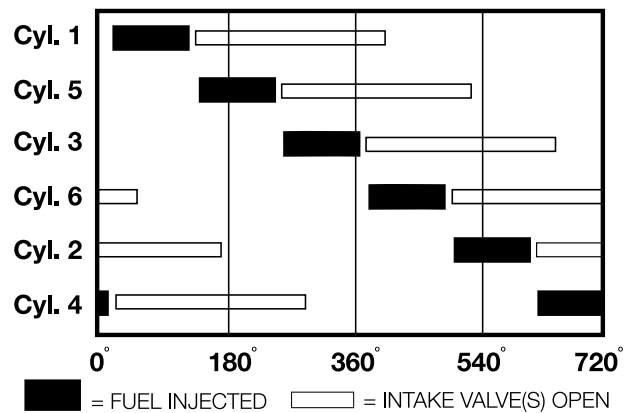

13410077.eps

The Injector “open” Time to maintain engine operation after it has been started is determined by the ECM (programming). The ECM will calculate the injector timing based on a combination of the following inputs:

- | |
|---|
| 1. Battery Voltage |
| 2. Accelerator Pedal Sensor |
| 3. Air Flow Volume |
| 4. Air Temperature |
| 5. Crankshaft Position / RPM |
| 6. Camshaft Position (Cylinder ID) |
| 7. Engine Coolant Temperature |
| 8. Oxygen Sensor (details in Emissions Management) |

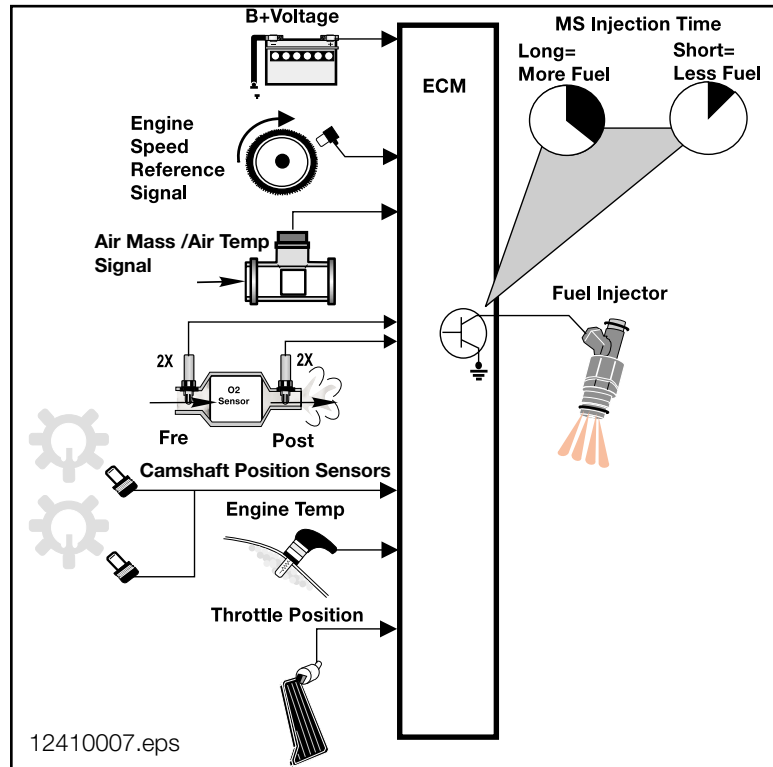

The injection ms value will be regulated based on battery voltage. When cranking, the voltage is low and the ECM will increase the ms value to compensate for injector “lag time”. When the engine is running and the battery voltage is higher, the ECM will decrease the injection ms value due to faster injector reaction time.

Cold starting requires additional fuel to compensate for poor mixture and the loss of fuel as it condenses onto cold intake ports, valves and cylinder walls. The cold start fuel quantity is determined by the ECM based on the Engine Coolant Temperature Sensor input during start up.

During cranking, additional fuel is injected for the first few crankshaft revolutions. The ECM recognizes the Camshaft Positions and precisely times the Full Sequential Injection. After the first few crankshaft revolutions, the injected quantity is metered down as the engine comes up to speed.

When the engine is cold, optimum fuel metering is not possible due to poor air/fuel mixing and an enriched mixture is required. The Coolant Temperature input allows the ECM to adjust the injection ms value to compensate during warm up and minimize the the inject- ed fuel at engine operating temperature.

When the engine is at idle, minimum injection is required. Additional fuel will be added if the ECM observes low engine rpm and increasing throttle/air volume inputs (acceleration enrichment). As the accelerator pedal is actuated, the ECM monitors acceleration and rate of movement. The ECM will increase the volume of fuel injected into the engine by increasing the injection ms value. The “full throttle” position indicates maximum acceleration and the ECM will add more fuel (full load enrichment).

As the accelerator pedal is released, the ECM decreases the injection ms value (fuel shut off) if the rpm is above idle speed (coasting). This feature decreases fuel consumption and lowers emissions. When the engine rpm approaches idle speed, the injection ms value is increased (cut-in) to prevent the engine from stalling. The cut-in rpm is dependent upon the engine temperature and the rate of deceleration.

The HFM signal provides the measured amount of intake air volume. This input is used by the ECM to determine the amount of fuel to be injected to “balance” the air/fuel ratio.

The Air Temperature Signal allows the ECM to make a calculation of air density. The varying voltage input from the NTC sensor indicates the larger proportion of oxygen found in cold air, as compared to less oxygen found in warmer air. The ECM will adjust the amount of injected fuel because the quality of combustion depends on oxygen sensing ratio (details in Emissions).

The Crankshaft Position/RPM signals the ECM to start injection as well as providing information about the engine operation. This input is used in combination with other inputs to determine engine load which increases/decreases the injection ms value. Without this input, the ECM will not activate the injectors.

When KL15 is switched “off”, the ECM discontinues voltage to the Fuel Injector Relay and deactivates the Final Stage transistors to cease fuel injection.

Injection “Reduction” Time is required to control fuel economy, emissions, engine and vehicle speed limitation. The ECM will “trim” back or deactivate the fuel injection as necessary while maintaining optimum engine operation.

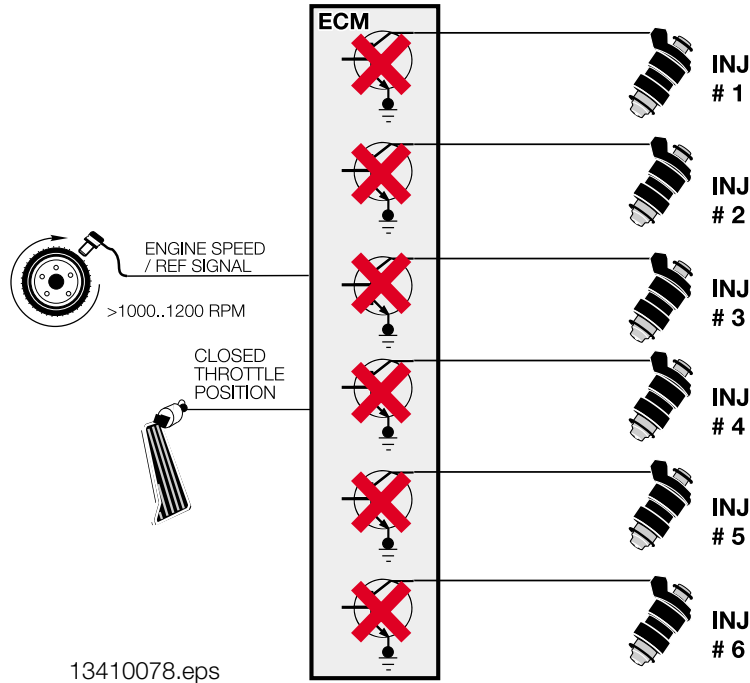

13410078.eps

As the throttle is closed during deceleration, the ECM decreases the injection ms value (fuel shut off) if the rpm is above idle speed (coasting). This feature decreases fuel consumption and lowers emissions.

When the engine rpm approaches idle speed, the injection ms value is increased (cut-in) to prevent the engine from stalling. The cut-in rpm is dependent upon the engine temperature and the rate of deceleration.

The ECM will deactivate the injectors to control maximum engine rpm (regardless of vehicle speed). When the engine speed reaches 8000 rpm, the injectors will be deactivated to protect the engine from over-rev. As the engine speed drops below 8000 rpm, injector activation will be resumed. This feature does not protect the engine from a forced over-rev such as improperly downshifting a manual transmission equipped vehicle (driver error).



13410075.tiff

Maximum vehicle speed is limited by the ECM reducing the injection ms value (regardless of engine rpm). This limitation is based on the vehicle dimensions, specifications and installed tires (speed rating).

The ECM will also protect the Catalytic Converters by deactivating the injectors.

If the ECM detects a fault in the ignition system or combustion (misfire detection), it will selectively deactivate the Final Stage output transistor for that cylinder. On the MS S54 system, the injectors have independent circuits. The injector will not open, preventing unburned fuel from entering the exhaust system. This will limit engine power, but protect the Catalytic Converters. The engine can still be operated on the remaining cylinders for “limp home” mode.

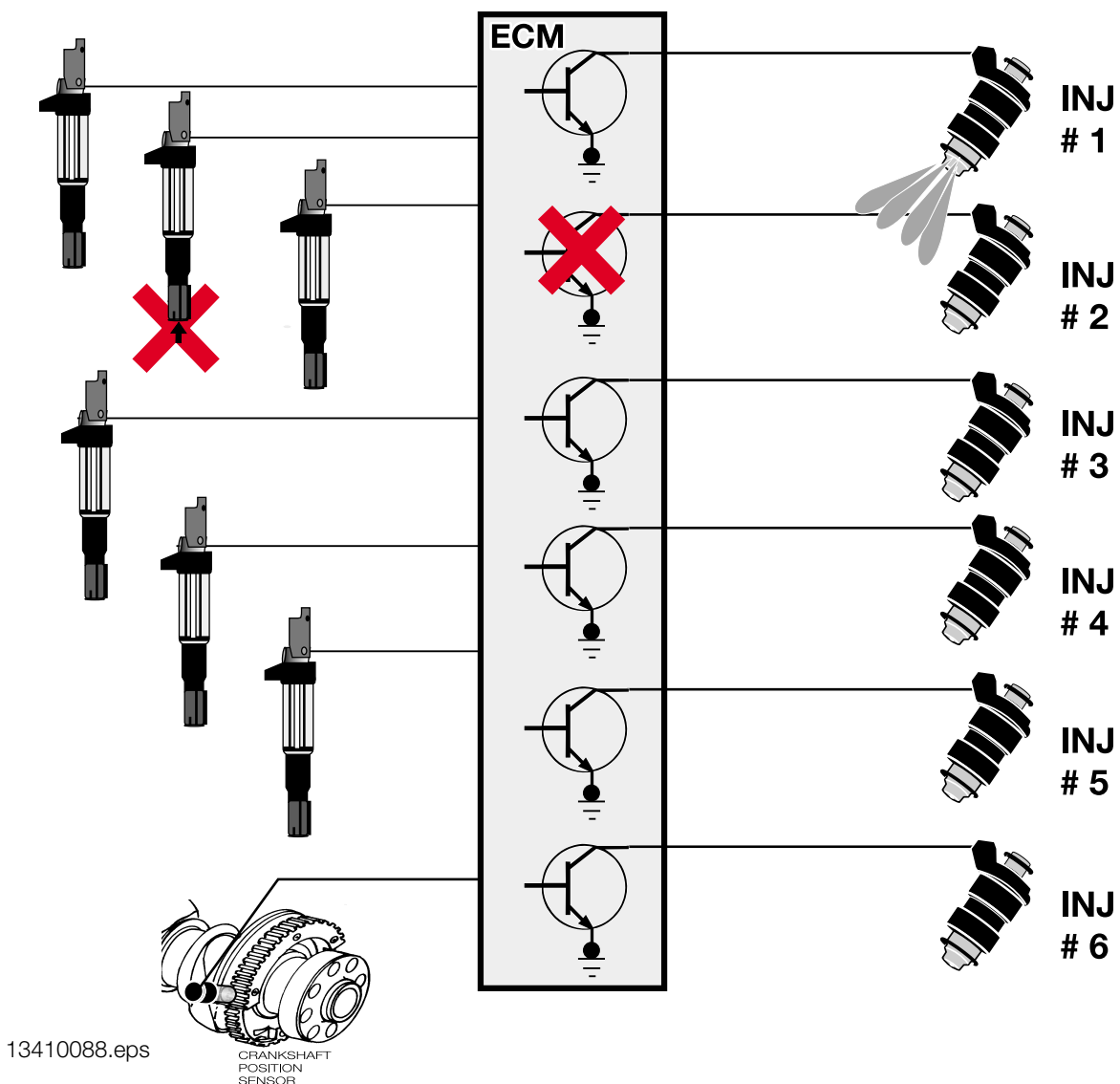

Workshop Hints

Before any service work is performed on any fuel system related component, always adhere to the following:

- Observe relevant safety legislation pertaining to your area.
- Ensure adequate ventilation
- Use exhaust extraction system where applicable (alleviate fumes).
- **DO NOT OPERATE THE FUEL PUMP** unless it is properly installed in the fuel tank and is submerged in the fuel (fuel lubricates the pump).
- **DO NOT SMOKE** while performing fuel system repairs.
- Always wear adequate protective clothing including eye protection.
- Use caution when working around a **HOT** engine compartment.
- BMW does not recommend any **UNAUTHORIZED MODIFICATIONS** to the fuel system. The fuel systems are designed to comply with strict federal safety and emissions regulations. In the concern of product liability, it is unauthorized to sell or perform modifications to customer vehicles, particularly in safety related areas.
- Always consult the **REPAIR INSTRUCTIONS** on the specific model you are working on before attempting a repair.

Fuel

Fuel quality should always be considered when diagnosing a driveability complaint. The type of fuel, proper AKI rating, impurities and moisture are not factored by the ECM.

Please refer to the Owner's Manual and following Service Information Bulletins regarding fuel:

- Gasoline Fuel Quality S.I. #13 01 88 (1564)
- Gasoline Additive S.I. #13 04 88 (1591)

Fuel Supply

The fuel supply hardware should be visually inspected for damage that can affect pick-up, transfer, pressure and return.

Please refer to the Repair Instructions and Service Information Bulletins details on fuel supply hardware.

Fuel Pump and Sending Unit Access

All BMW vehicles have access plates to service the fuel pump and sending units without removing the fuel tank.

The access plates are located under the rear seat.

The “saddle” type fuel tank (under rear seat) has two access plates.

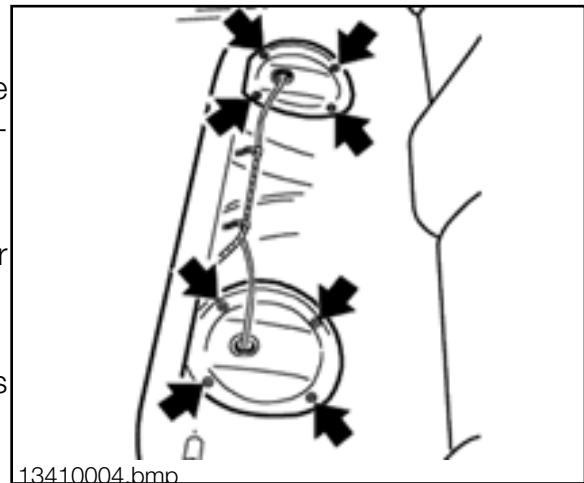

The passenger side allows access to the fuel pump/sending unit.

The driver side accesses the sending unit.

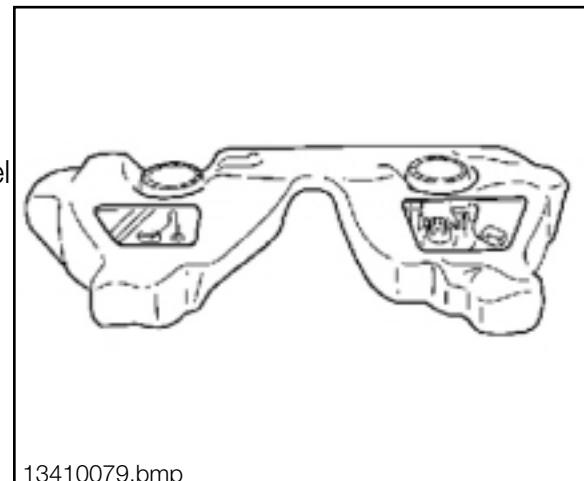

Draining the Fuel Tank

In order to remove the fuel tank it must be drained first to avoid fuel spills and handling excessive weight. In some cases depending on the fuel tank dimensions (vehicle specific), it is also necessary to drain the fuel tank to replace the sending units and/or fuel pump.

CAUTION: In some vehicles, the sending units/fuel pump is mounted lower than the top of the fuel tank. A fuel spill will be encountered if the fuel is not drained.

NOTE: Consult the BMW Service Workshop Equipment for the proper evacuation equipment.

The saddle type tank requires an additional step to drain the fuel from the driver side. The evacuation equipment should be attached to the tank compensating hose (arrow) to drain out the remaining fuel.

Fuel Pump/Pressure Regulator - Testing

The fuel pump should be tested for delivery pressure and volume. **Caution** when disconnecting fuel hoses because there is the possibility of residual fuel pressure! Install the fuel pressure gage at the pressure test point at the fuel filter.

Remove the fuel pump relay (see relay testing in the power supply section) and connect the Relay Bypass Switch to the relay socket. This will activate the fuel pump without running the engine.

If the 5 bar fuel pressure is not achieved or bleed off is more than 0.5 bar, refer to **13 31 of the Repair instructions** for further diagnosis.

The Fuel Hose Clamp Tool can be used to isolate bleed off from the pump (non-return check valve) or the pressure regulator (restriction valve). Also verify power supply to the fuel pump.

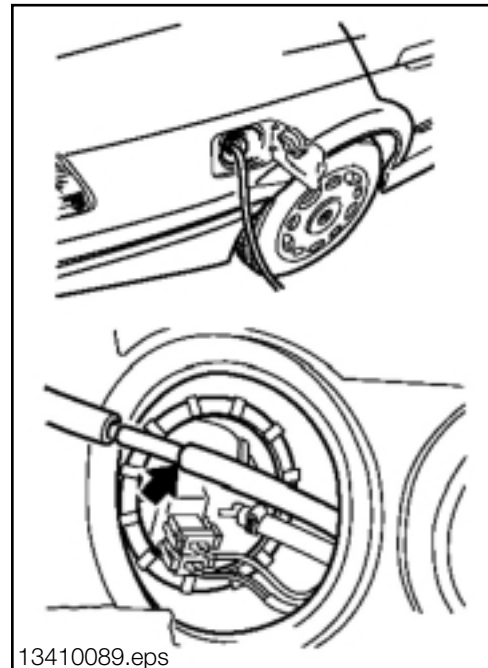

Fuel volume must be tested to verify:

- | | |
|----|--|
| 1. | Fuel Pump Output |
| 2. | Restriction are not present in the pump, lines/hoses and fuel filter. |

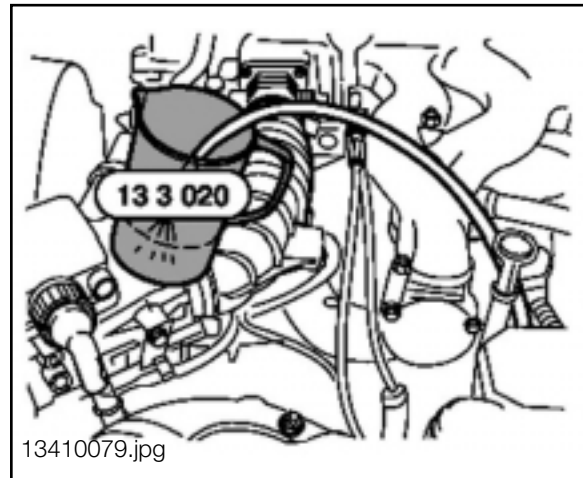

Fuel Injectors

When inspecting the fuel injectors, consider the following:

- | | |
|----|---|
| 1. | O-rings should be replaced, lubricate with Vaseline or SAE 90 gear oil for installation. |
| 2. | Verify the code number. |
| 3. | Color code injector housing |

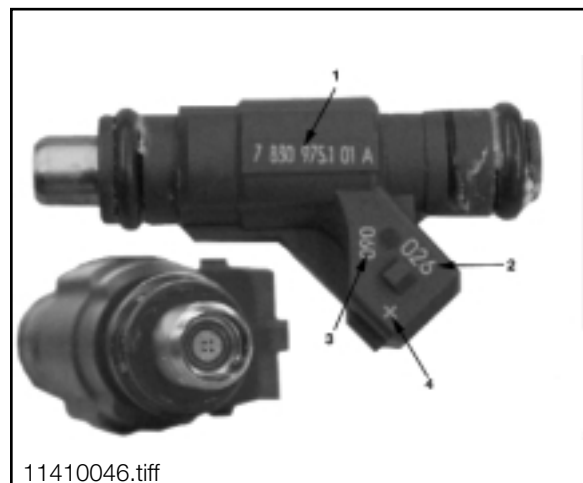

Fuel injectors can leak which bleeds off fuel pressure and increases emissions. The injectors can be tested using the Fuel Injector Leakage Tester.

The fuel injectors can be cleaned, refer to Service Information Bulletin S.I. #04 07 86.

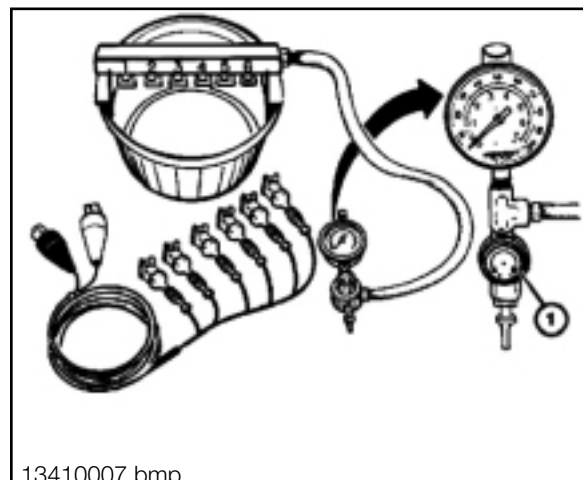

The Fuel Injectors should also be tested using the DIS/MoDIC for:

- | | |
|----|--|
| 1. | Resistance |
| 2. | Power Supply |
| 3. | Status Display- Fuel Injection Signal |
| 4. | ECM Final Stage transistor activation. This test function is found under the Oscilloscope Preset list-"Ti Injection Signal" Install the 88 pin adapter, Diagnostic cable MFK 2 positive lead to the ground activation circuit for the injector. This test is performed with the engine running. |

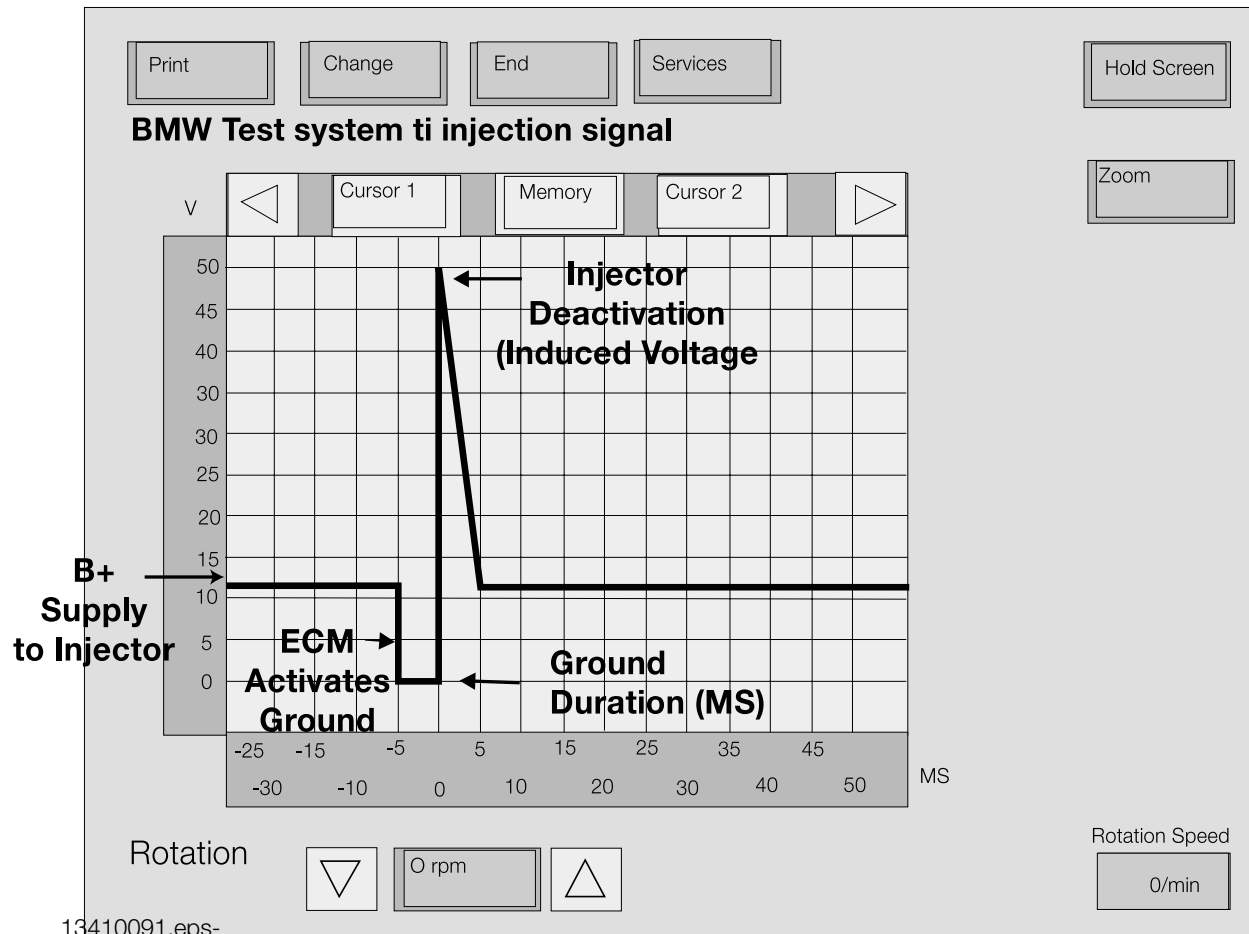
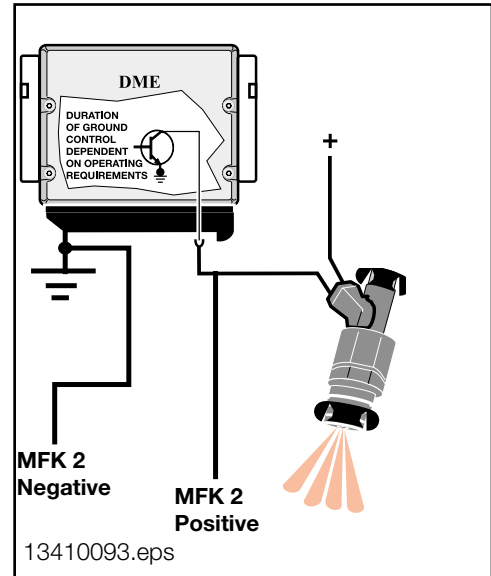

Crankshaft Position/RPM Sensor

This sensor should be tested using the DIS/MoDIC for:

1.	Power Supply
2.	AC Voltage
3.	Status Display
4.	Oscilloscope Display Found Under Preset List "Rotation Speed Sensor Signal"

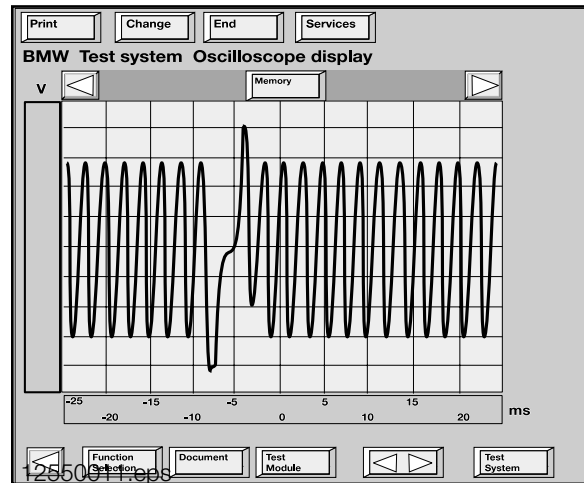

Camshaft Position Sensor (Cylinder ID)

This sensor should be tested using the DIS/MoDic for:

1.	Power Supply
2.	DC Voltage
3.	Status Display
4.	Oscilloscope Display Found Under Preset List "Rotation"

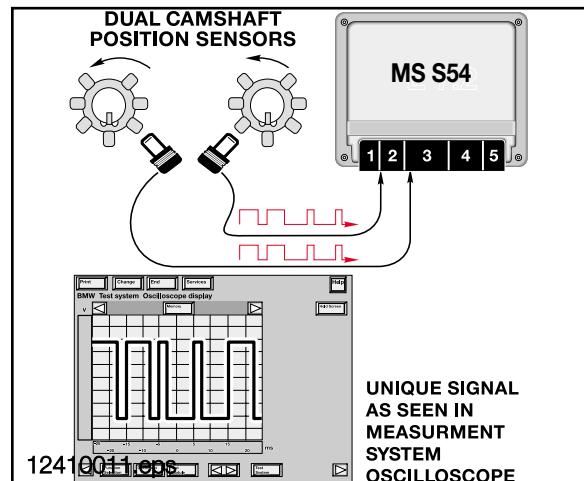

Engine Coolant Temperature

This Sensor should be tested using:

1.	DIS / Modic Status Page - Degrees C (dependent on engine temperature)
2.	DIS / Modic Multimeter - Resistance

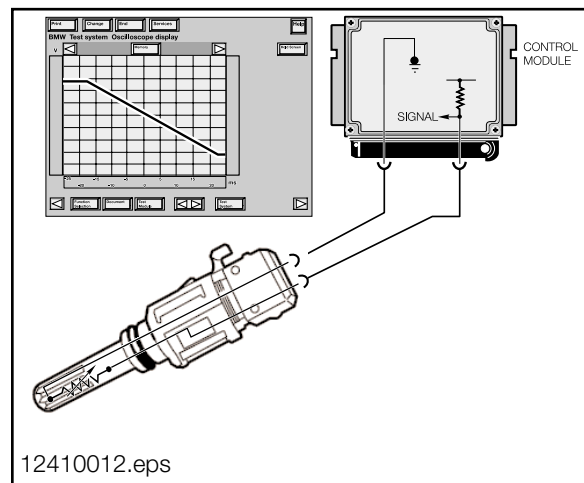

Tools and Equipment

The DIS/Modic as well as a reputable hand held multimeter can be used when testing inputs/components.

It is best to make the checks at the ECM connection, this method includes testing the wiring harness.

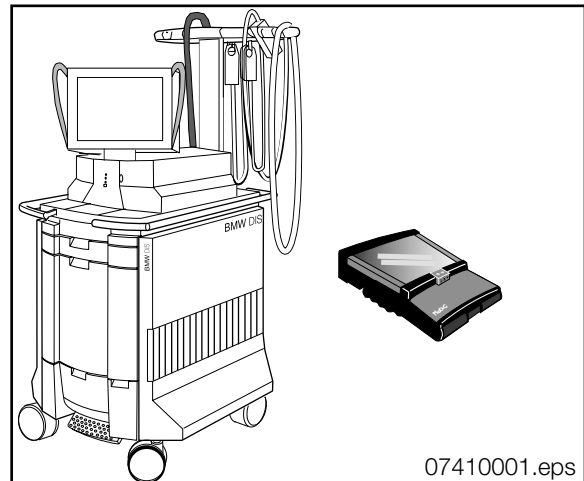

The correct Universal Adapter for the MS S54 application should be used (#90 88 6 121 300). This will ensure the pin connectors and the harness will not be damaged.

When installing the Universal Adapter to the ECM (located in the Electronics Box in the engine compartment), make sure the ignition is switched off.

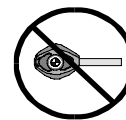
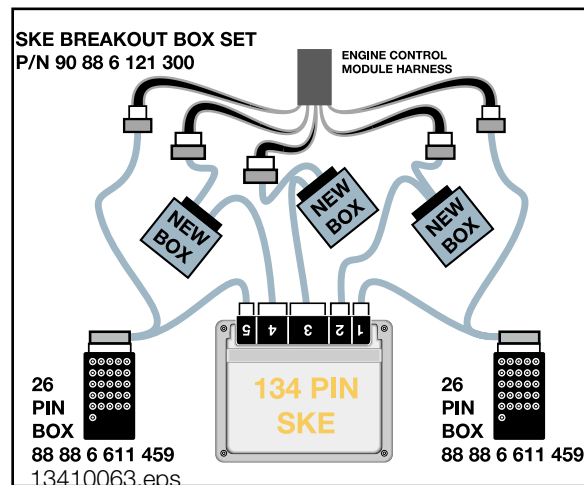

The Fuel Hose Clamp Tool (#13 3 010) can be used for isolating pressure faults. In addition, fuel loss can be reduced when changing the fuel filter while loosening clamps (1 and 2).

The Relay Bypass Switch (#61 3 050) must be used especially **when fuel vapors are present!** The switch eliminates the risk of electrical arcing.

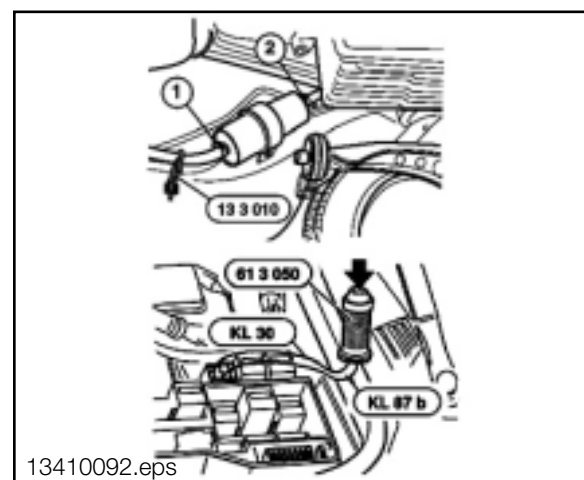

When testing fuel pressure, the DIS is equipped with a pressure measuring function, found in Measurement testing can be used.

A threaded fitting provides a test point at the fuel pressure regulator. This threaded adapter fitting allows Adapter #13 5 220 to be coupled to the DIS Pressure Adapter.

Caution! Residual fuel pressure may be present.

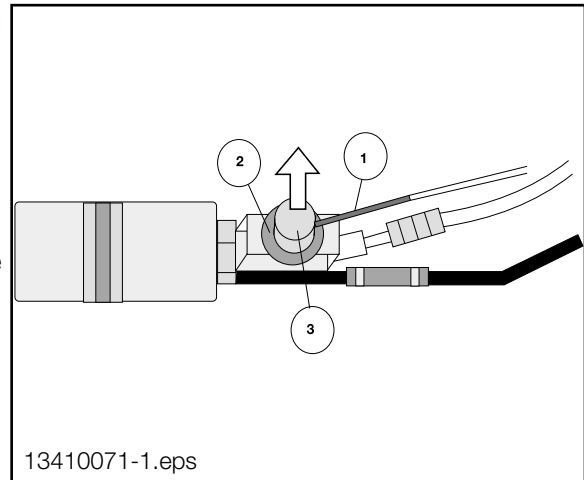

When testing the fuel injectors for leakage, use Special Tool #88 88 5 000 362. Leak testing the fuel injectors is one of the diagnostic steps listed in "Long Cranking Times" S.I. #13 08 90 (3096).

This tool pressurizes the injectors with air and the injector tips are submersed in water. If air bubbles are present, this indicates the leaking injector(s).

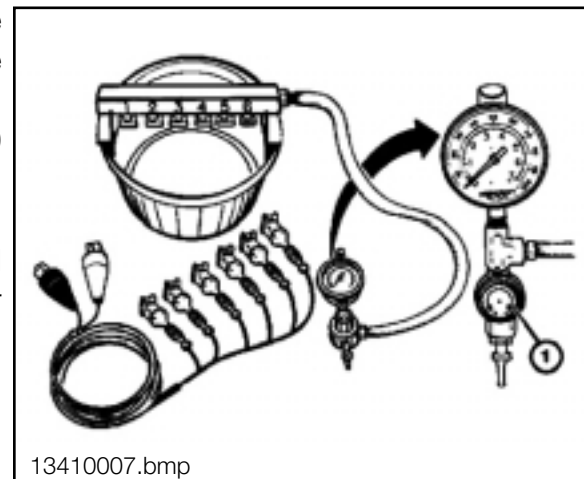

Ignition Management

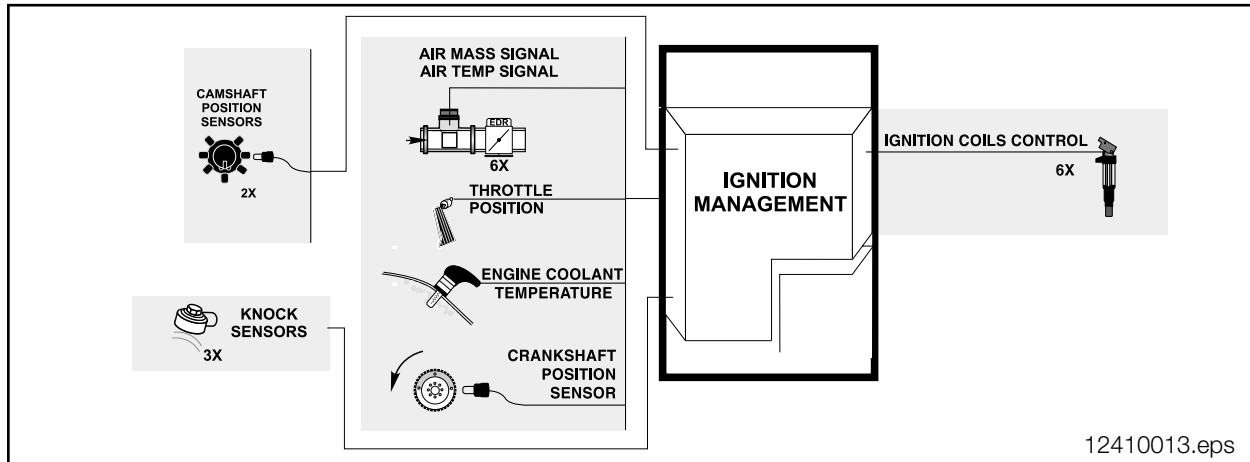

Ignition Coils: The high voltage supply required to ignite the mixture in the combustion chambers is determined by the stored energy in the ignition coils. The stored energy contributes to the ignition duration, ignition current and rate of high voltage increase. The Coil circuit including primary and secondary components consists of:

1.	Coil Assembly - Primary Winding - Secondary Winding
2.	Insulator Boot
3.	Spark Plug
4.	ECM Final Stage Transistor
5.	Secondary Coil Ground

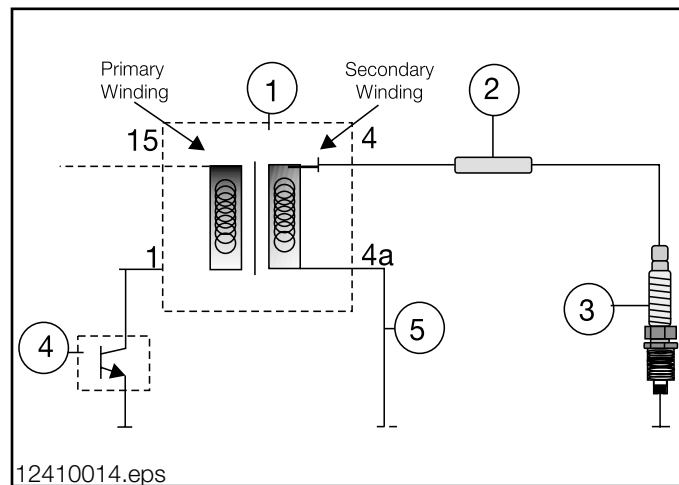

The Coil Assembly contains two copper windings insulated from each other. One winding is the primary winding, formed by a few turns of thick wire. The secondary winding is formed by a great many turns of thin wire.

The primary winding receives battery voltage from the ECM Relay (Coil Terminal 15). The ECM provides a ground path for the primary coil (Coil Terminal 1) by activating a Final Stage transistor. The length of time that current flows through the primary winding is the “dwell” which allows the coil to “saturate” or build up a magnetic field. After this storage process, the ECM will interrupt the primary circuit at the point of ignition by deactivating the Final Stage transistor. The magnetic field built up within the primary winding collapses and induces the ignition voltage in the secondary winding.

The high voltage generated in the secondary winding is discharged through Coil Terminal 4 to the spark plug (insulated by the boot connector).

The primary and secondary windings are uncoupled, therefore, the secondary winding requires a ground supply (Coil Terminal 4a).

There is an individual ignition circuit and coil for each cylinder on the MS S54 system. The S54 uses “pencil type” ignition coils manufactured by Bremi. The six individual ignition coils are integrated with the insulated connector (boot).

The coils are removed by lifting the swivel latch connector retainer to release the wiring harness, apply a slight twist and lift the assembly upwards.

The primary ignition cables are routed on the top of the cylinder head cover. A suppression capacitor is installed on the secondary ignition ground circuit (arrow).

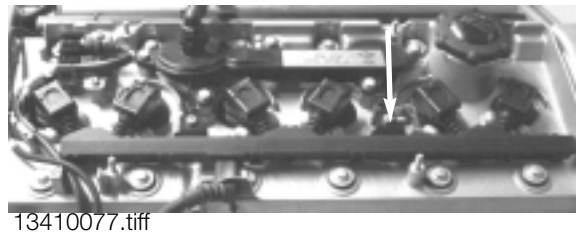
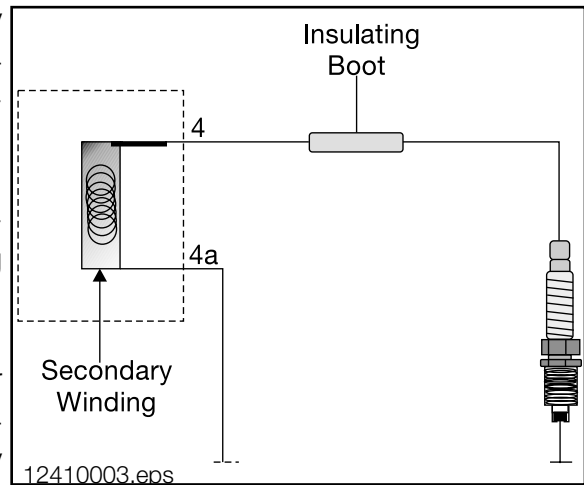

Spark Plugs: The spark plugs introduce the ignition energy into the combustion chamber. The high voltage “arcs” across the air gap in the spark plug from the positive electrode to the negative electrodes. This creates a spark which ignites the combustible air/fuel mixture.

The spark plugs are located in the center of the combustion area (on the top of the cylinder head) which is the most suitable point for igniting the compressed air/fuel mixture.

The correct spark plugs for the S54 are NGK DCPR8EKP dual electrode (non-adjustable gap).

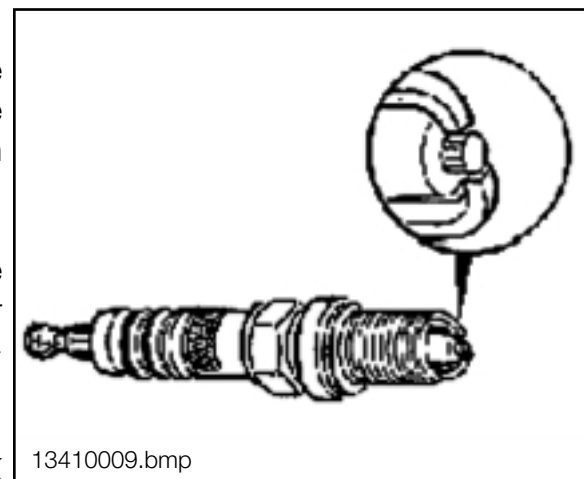

Faults with the Ignition Output Components are monitored by the ECM. If there are faults with the igniton coil(s) output, and/or spark plugs, the following complaints could be encountered:

1.	“ENGINE EMISSION” Light with Mixture Related and/or Misfire Fault Codes
2.	Poor Engine Performance
3.	Engine Misfire
4.	No Start/Hard Starting
5.	Excessive Exhaust Emission/Black Smoke

The Ignition Ouput Components must be individually tested (see Workshop Hints).

The **primary ignition** circuits are monitored by the ECM.

If a fault is present, the “ENGINE EMISSION” Light will illuminate and the ECM will deactivate the corresponding fuel injector for that cylinder. Engine operation will still be possible.

The **secondary ignition** is monitored by the ECM via the Crankshaft Position/RPM Sensor.

If a Misfire fault is present, the “ENGINE EMISSION” Light will illuminate and the ECM will deactivate the corresponding fuel injector for that cylinder. Engine operation will still be possible.

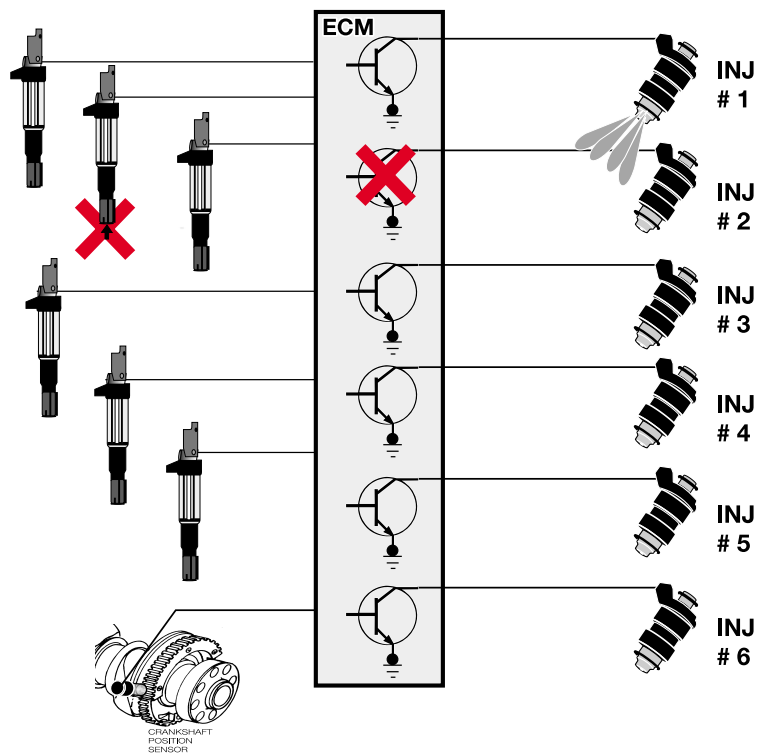

13410088.eps

Knock Sensors: are required to prevent detonation (pinging) from damaging the engine. The Knock Sensor is a piezoelectric conductor-sound microphone. The ECM will retard the ignition timing (cylinder selective) based on the input of these sensors. Detonation can occur due to:

1. High Compression Ratio	4. Maximum Timing Advance Curve
2. Poor Quality Fuel (Octane Rating)	5. High Intake Air and Engine Temperatures
3. High Level of Cylinder Filling	6. Carbon Build-Up (Combustion Chamber)

The Knock Sensor consists of:

1. Shielded Wire
2. Cup Spring
3. Seismic Mass
4. Housing
5. Inner Sleeve
6. Piezo-Ceramic Element

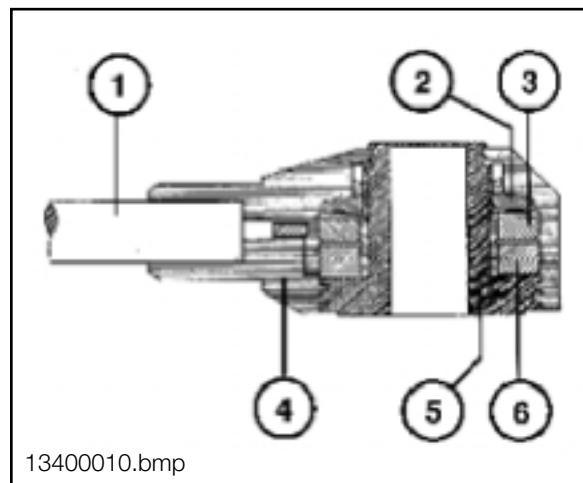

A piezo-ceramic ring is clamped between a seismic mass and the sensor body. When the seismic mass senses vibration (flexing), it exerts a force on the piezo-ceramic element. Opposed electrical charges build up on the upper and lower ceramic surfaces which generates a voltage signal. The acoustic vibrations are converted into electrical signals. These low voltage signals are transmitted to the ECM for processing.

There are three Knock Sensors bolted to the engine block between cylinders 1 & 2, 3 & 4 and 5 & 6. If the signal value exceeds the threshold, the ECM identifies the “knock” and retards the ignition timing for that cylinder.

If a fault is detected with the sensor(s), the ECM deactivates Knock Control and the “ENGINE EMISSION” Light will be illuminated. The ignition timing will be set to a conservative basic setting based on intake air temperature and a fault will be stored.

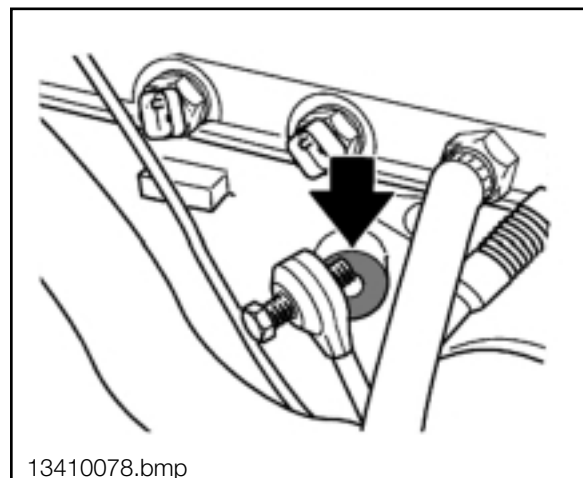

Crankshaft Position/RPM Sensor: This sensor provides the crankshaft position and engine speed (RPM) signal to the ECM for ignition activation and correct timing. This input is also monitored for Misfire Detection. For details about the sensor, refer to the Fuel Management section.

A fault with this input will produce the following complaints:

1.	No Start
2.	Intermittent Misfire/Driveability
3.	Engine Stalling

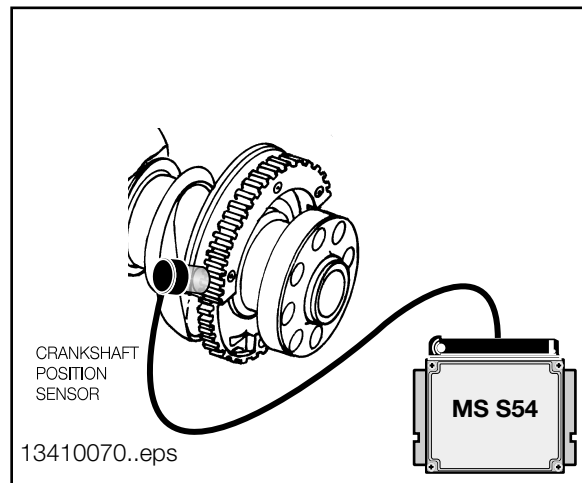

Camshaft Position Sensor (Cylinder Identification): The camshaft sensors (Hall type) inputs allows the ECM to determine camshaft positions in relation to crankshaft position. It is used by the ECM to establish the “working cycle” of the engine for precise ignition timing. For details about the sensor, refer to the Fuel Management section.

If the ECM detects a fault with the Camshaft Sensors, the “ENGINE EMISSION” Light will be illuminated and the ignition will still operate based on the Crankshaft Position/RPM Sensor.

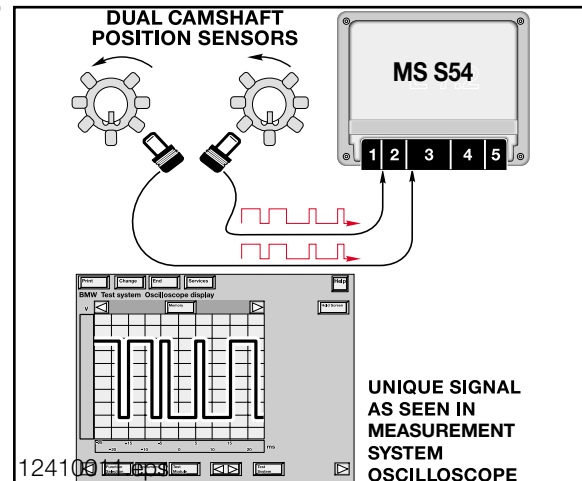

Engine Coolant Temperature: The ECM determines the correct ignition timing required for the engine temperature. For details about the sensor, refer to the Fuel Management section. This sensor is located in the coolant return pipe on the cylinder head (1).

If the Coolant Temperature Sensor input is faulty, the “ENGINE EMISSION” Light will be illuminated and the ECM will use the oil temperature sensor as an alternate. The ignition timing will be set to a conservative basic setting.

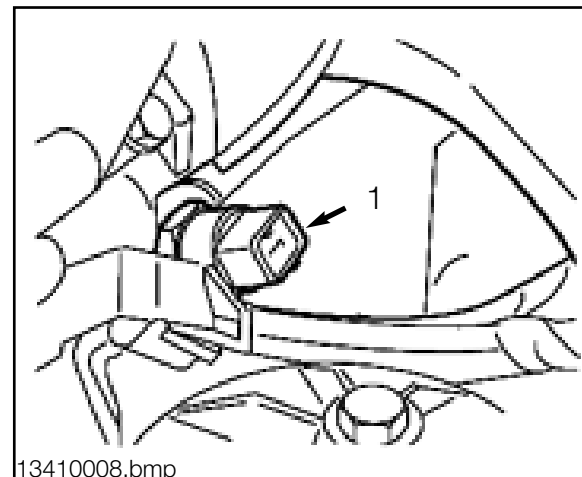

Accelerator Pedal Position (PWG): As the accelerator pedal is actuated, the ECM will advance the ignition timing. The “full throttle” position indicates maximum acceleration to the ECM, the ignition will be advanced for maximum torque.

For details about the sensor, refer to the Air Management section.

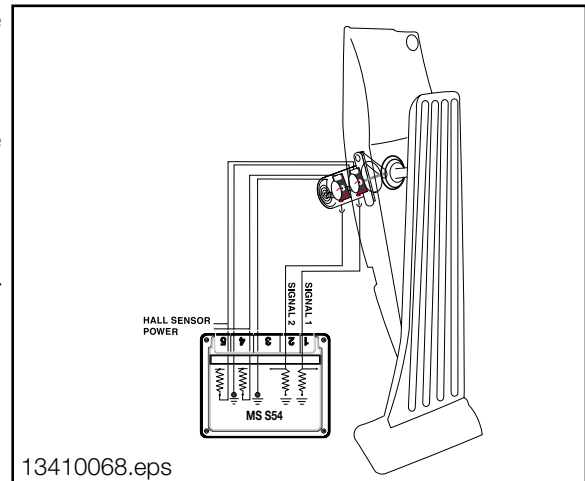

Hot-Film Air Mass Meter (HFM): The air volume input signal is used by the ECM to determine the amount of ignition timing advance.

For details about the sensor, refer to the Air Management section.

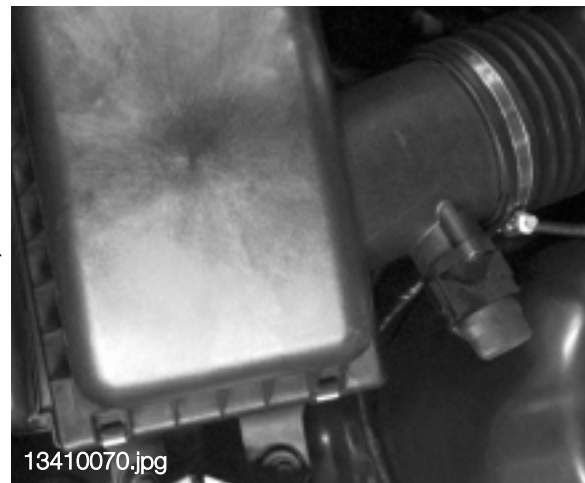

Air Temperature: This signal allows the ECM to make a calculation of air density. The sensor is located in the HFM. For details about the sensor, refer to the Air Management section.

The ECM will adjust the ignition timing based on air temperature. If the intake air is hot the ECM retards the ignition timing to reduce the risk of detonation. If the intake air is cooler, the ignition timing will be advanced.

If this input is defective, a fault code will be set and the “ENGINE EMISSION” Light will illuminate. The ignition timing will be set to a conservative basic setting.

Principle of Operation

Ignition Management provides ignition to the combustion chambers with the required voltage at the correct time. Based on the combination of inputs, the ECM calculates and controls the **ignition timing** and **secondary output voltage** by regulating the activation and dwell of the **primary ignition circuit**. The ECM controls and monitors the primary ignition circuit as well as the secondary ignition output (Misfire Detection).

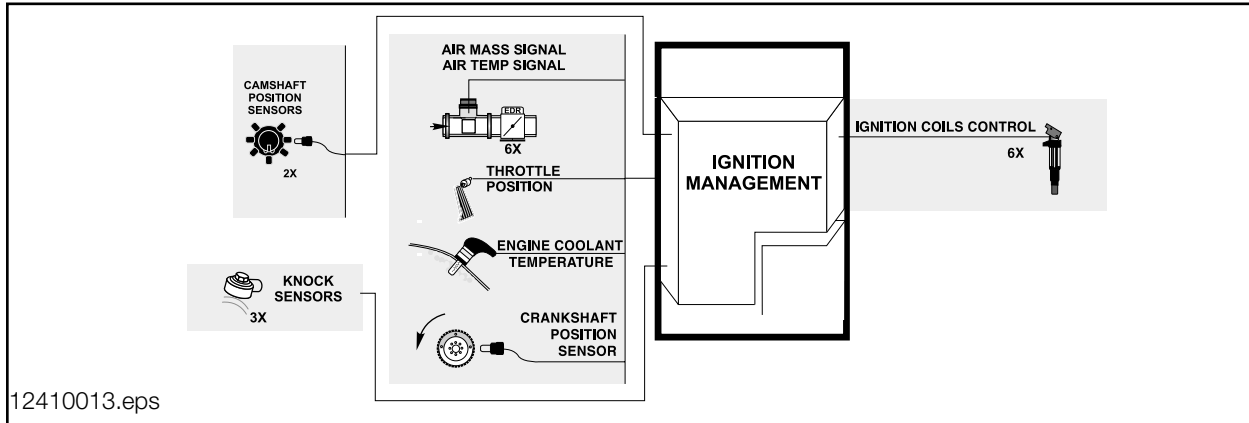

The ECM has a very “broad” range of ignition timing. This is possible by using a Direct Ignition System, or sometimes referred to as “Static Ignition System” (RZV). Reliability is also increased by having separate individual ignition circuits.

The Ignition Control is determined by the ECM (load dependant). The ECM will calculate the engine “load” based on a combination of the following inputs:

1. Battery Voltage	4. Accelerator Pedal Position	7. Knock Sensor
2. Air Temperature	5. Engine Coolant	8. Air Flow Volume
3. Camshaft Position (Cylinder ID)	6. Crankshaft Position/RPM	

The dwell time will be regulated based on battery voltage. When cranking, the voltage is low and the ECM will increase the dwell to compensate for saturation “lag time”. When the engine is running and the battery voltage is higher, the ECM will decrease the dwell due to a faster saturation time.

The Crankshaft Position/RPM signals the ECM to start ignition in firing order (1-5-3-6-2-4) as well as providing information about the engine operation. This input is used in combination with other inputs to determine engine load which advances/retards the ignition timing. Without this input, the ECM will not activate the ignition.

Cold start is determined by the ECM based on the engine coolant temperature and rpm during start up. A cold engine will crank over slower than a warm engine, the ignition timing will range between top dead center to slightly retarded providing optimum starting.

When starting a warm engine, the rpm is higher which results in slightly advanced timing. If the engine coolant and intake air temperature is hot, the ignition timing will not be advanced reducing starter motor “load”.

During cranking, the ECM recognizes the Camshaft Position (compression stroke) and activates a single ignition per cylinder. The ignition timing will be progressively advanced assisting the engine in coming up to speed.

As the engine speed approaches idle rpm, the timing remains slightly advanced to boost torque.

When the engine is at idle speed, minimum timing advance is required. This will allow faster engine and catalyst warm up.

The timing will be advanced when the ECM observes low engine rpm and increasing accelerator/air volume inputs (acceleration torque). As the throttle is opened, the ECM advances the timing based on engine acceleration and at what rate. The ECM will fully advance timing for the “full throttle” position indicating maximum acceleration (torque).

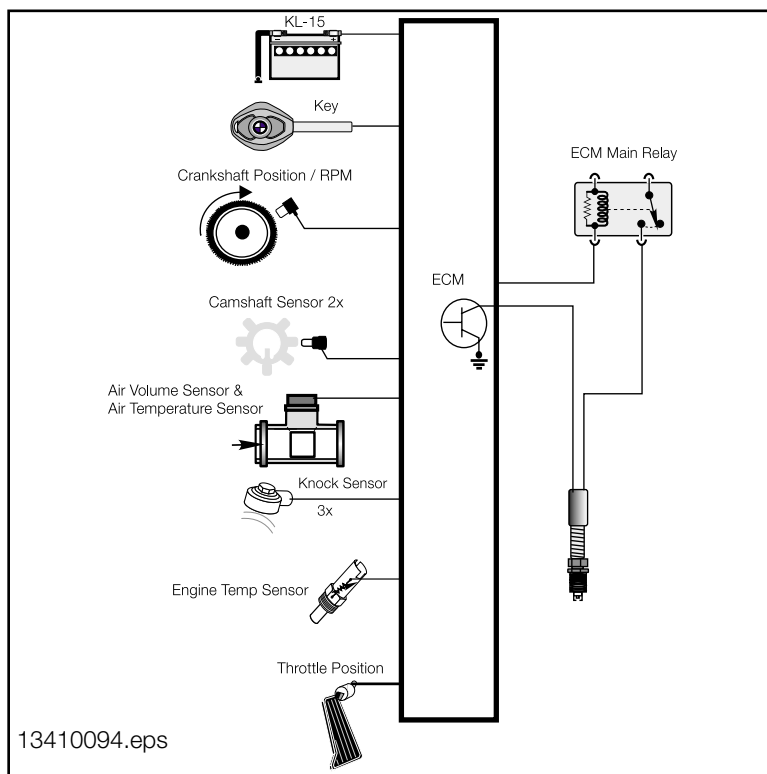

The Air Flow Volume signal provides the measured amount of intake air volume. This input is used by the ECM to determine the amount of timing advance to properly combust the air/fuel mixture.

The Air Temperature Signal assists the ECM in reducing the risk of detonation (ping). If the intake air is hot the ECM retards the ignition timing. If the intake air is cooler, the ignition timing will be advanced.

As the throttle is closed, the ECM decreases the ignition timing if the rpm is above idle speed (coasting). This feature lowers the engine torque for deceleration. When the engine rpm approaches idle speed, the timing is slightly advanced to prevent the engine from stalling. The amount of advance is dependent upon the engine temperature and the rate of deceleration.

EMISSION OPTIMIZED - IGNITION KEY OFF

“Emission Optimized Ignition Key Off” is a programmed feature of the MS 54 ECM. After the ECM detects KL 15 is switched “off”, the ignition stays active (ECM Relay/voltage supply) for two more individual coil firings. This means that just two cylinders are fired - not two revolutions.

This feature allows residual fuel injected into the cylinders, as the ignition key is switched off, to be combusted as the engine runs down.

EMISSION OPTIMIZED IGNITION KEY OFF

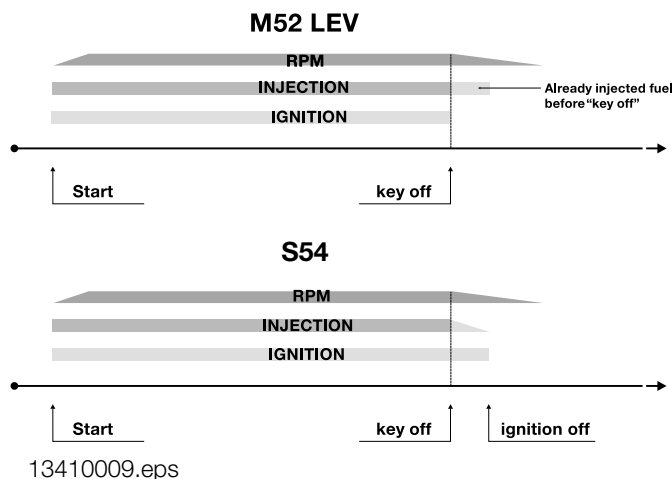

When **KL15** is switched “off” the ECM operating voltage is removed. The ECM will maintain a ground to the Engine Control Module Relay for a few seconds to maintain ignition coil activation.

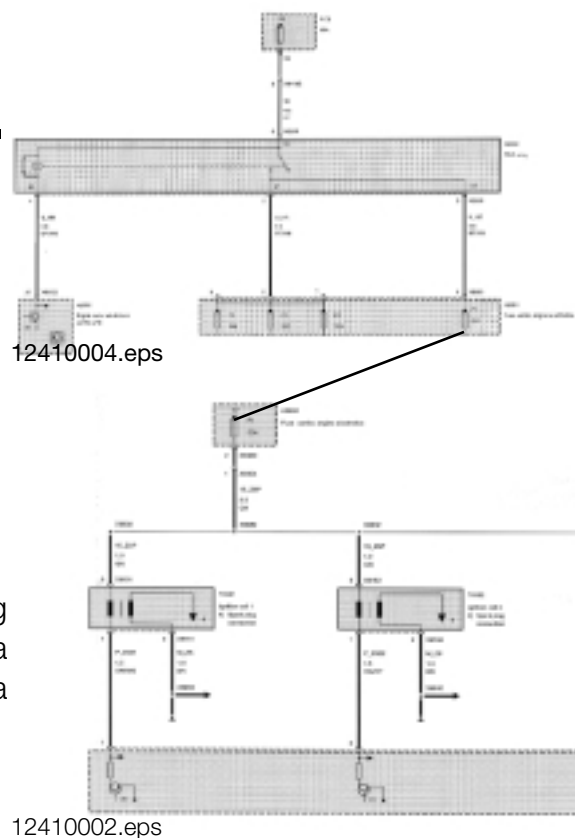

Knock Control

The use of Knock Control allows the ECM to further advance the ignition timing under load for increased torque. This system uses three Knock Sensors located between cylinders 1 & 2, cylinders 3 & 4 and cylinders 5 & 6.

Knock Control is only in affect when the engine temperature is greater than 35 °C and there is a load on the engine. This will disregard false signals while idling or from a cold engine.

Based on the firing order, the ECM monitors the Knock Sensors after each ignition for a normal (low) signal.

If the signal value exceeds the threshold, the ECM identifies the “knock” and retards the ignition timing (3°) for that cylinder the next time it is fired.

This process is repeated in 3° increments until the knock ceases. The ignition timing will be advanced again in increments right up to the knock limit and maintain the timing at that point.

If a fault is detected with the Knock Sensor(s) or circuits, the ECM deactivates Knock Control. The “ENGINE EMISSION” Light will be illuminated, the ignition timing will be set to a conservative basic setting (to reduce the risk of detonation) and a fault will be stored.

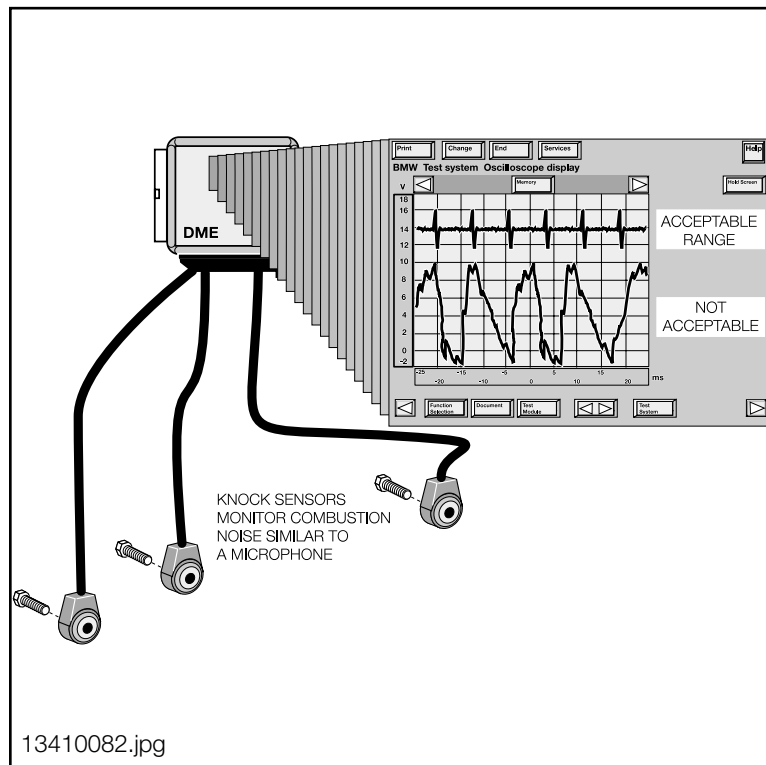

Workshop Hints

Before any service work is performed on any ignition system related component, always adhere to the following:

- Observe relevant safety legislation pertaining to your area.
- Always wear adequate protective clothing including eye protection.
- Use caution when working around a **HOT** engine compartment.
- Always consult the **REPAIR INSTRUCTIONS** on the specific model you are working on before attempting a repair.
- Always **switch off the ignition (KL15)** before working on the ignition system.
- Use only BMW approved test leads.
- **Never touch components conducting current** with the engine running!
- Do not connect suppression devices or a “test light” to terminal 1 of the ignition coils.
- Terminal 1 of the ignition coil must not be connected to Ground or B+.
- Never run the engine with a secondary ignition component disconnected.

HIGH VOLTAGE - DANGER!

Caution! Hazardous voltages occur at:

- Ignition Leads
- Spark Plug Connector
- Spark Plug
- Ignition Coil (High Voltage at terminal 4 is approximately 30 KV)
- Terminal 1 from the ignition coil to the ECM (High Voltage approximately 350 V)

Ignition System Diagnosis

A fault survey should first be performed using the DIS/MoDIC to determine if there is a fault in the primary ignition or secondary ignition.

If there is a fault in the primary ignition, testing should include:

- Power Supply at the Coil (KL15)
- Resistance of the harness and ignition coil primary winding (terminal 15 to 1 approx. 0.8 ohms) - using the 134 Pin Adapter Set with the ECM disconnected.

A.	ECM Primary Circuit Final Stage Transistor
B.	Ignition Coil (one of four)
C.	Secondary Coil Ground

- ECM Final Stage transistor activation. This test function is found under the Oscilloscope Preset list - "Ignition Signal Primary" (normal Terminal 1 Signal shown on the right).

Install the 134 Pin Adapter Set, Diagnostic cable, MFK 2 negative lead to ECM ground and MFK 2 positive lead to the ground activation circuit for Terminal 1 of the ignition coil. This test is performed with the engine running.

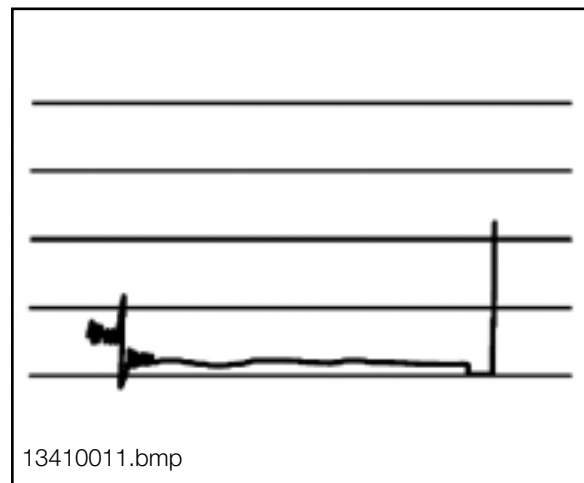
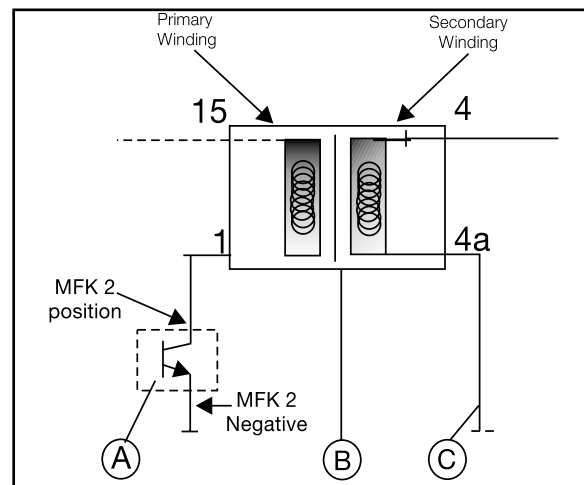

If there is a fault in the secondary ignition, testing should include:

- Primary Ignition
- Evaluation of Secondary Oscilloscope Patterns

The Repair Instructions should be consulted for additional Oscilloscope Patterns under various engine speeds.

In Summary,

If the Secondary Ignition **Voltage is Too High (Excessive Resistance for Ignition) :**

- Spark Plug Gap is too Large (Worn or Burned)
- Incorrect Heat Range Spark Plug
- Compression is too High (Carbon, etc.)
- Lean Mixture (Vacuum Leak, etc.)
- Interruption in the Secondary Ignition Cable, Connector, or Resistive Adapter Boot

If the Secondary Ignition **Voltage is Too Low (Low Resistance for Ignition):**

- Spark Plug Gap is Too Small (Mishandled on Installation)
- Incorrect Heat Range Spark Plug
- Compression is Too Low
- Voltage Leak in the Secondary Ignition Cable, Connector, or Resistive Boot to Ground

Spark Plugs

The Spark Plugs should be inspected for the proper type, gap and replaced at the specified intervals.

Refer to the Service Information Bulletin S.I. #12 01 99 for the proper type and a visual of the spark plug (showing effects of combustion, fouling, etc.)

Knock Sensors

The Knock Sensors should be tested using the DIS/MoDIC for:

1.	Fault Codes
2.	Status Display -Knock Control (active/not active)
3.	Oscilloscope Display (Low DC Voltage-mV Setting)

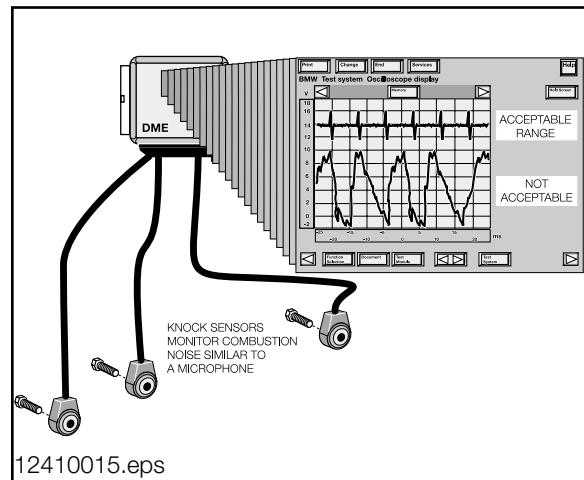

When installing Knock Sensors:

DO NOT MIX THE CONNECTORS: Engine Damage will result! - the connector is critical to sensor location.

Do Not Over Tighten attaching bolt! - Piezo ceramic will be cracked. Torque to 20 nm.

Do Not Under Tighten attaching bolt, a loose sensor can vibrate producing a similar signal to a knock.

Tools and Equipment

The DIS/Modic as well as a reputable hand held multimeter can be used when testing inputs/components. It is best to make the checks at the ECM connection, this method includes testing the wiring harness.

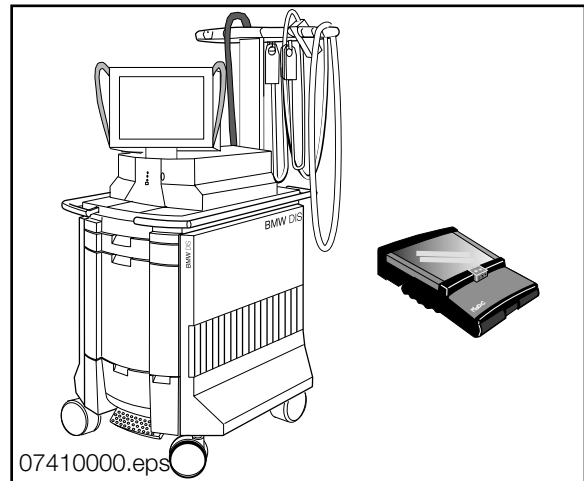

The correct Universal Adapter for the MS S54 application should be used (#90 88 6 121 300). This will ensure the pin connectors and the harness will not be damaged.

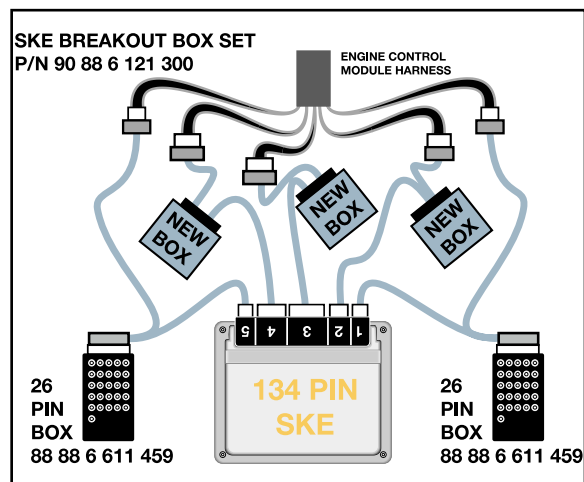

When installing the Universal Adapter to the ECM (located in the Electronics Box in the engine compartment), make sure the ignition is switched off.

When Testing the Secondary Ignition System, use the High Tension clip of the DIS. Refer to the HELP button for additional (on screen) connections.

13410063.eps

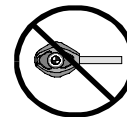

Caution! Observe Safety Precautions, High Voltage is Present with the Engine Running

The Spark Plugs should be properly installed and torqued using the following Special Tools:

- 12 1 200 Torque Adapter (prevents over tightening)
- 12 1 171 Spark Plug Socket

NOTE: NEVER USE AIR TOOLS FOR REMOVAL OR INSTALLATION!

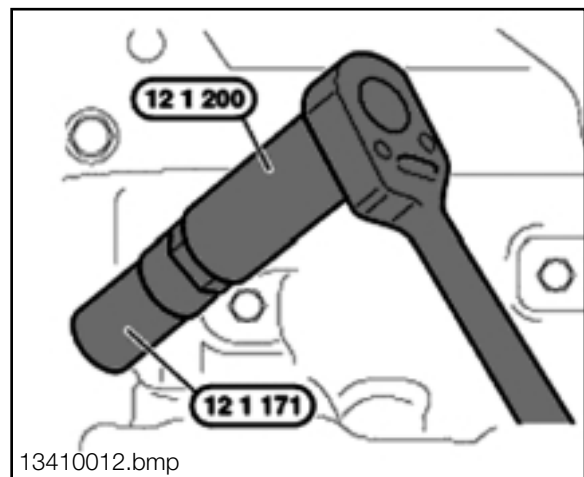

Emissions Management

Evaporative Emissions: The control of the evaporative fuel vapors (Hydrocarbons) from the fuel tank is important for the overall reduction in vehicle emissions.

The evaporative system has been combined with the ventilation of the fuel tank, which allows the tank to breath (equalization). The overall operation provides:

- An inlet vent, to an otherwise "sealed" fuel tank, for the entry of air to replace the fuel consumed during engine operation.
- An outlet vent with a storage canister to "trap and hold" fuel vapors that are produced by the expansion/evaporation of fuel in the tank, when the vehicle is stationary.

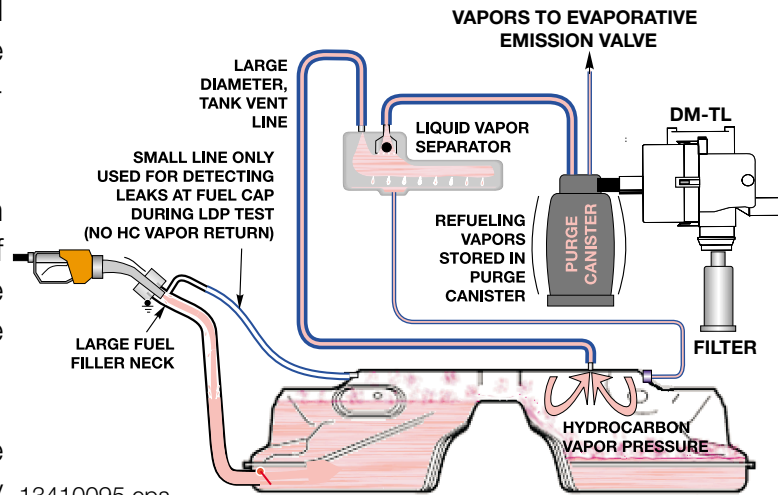

The canister is then "purged" using the engine vacuum to draw the fuel vapors into the combustion chamber. This "cleans" the canister allowing for additional storage. Like any other form of combustible fuel, the introduction of these vapors on a running engine must be controlled. The ECM controls the Evaporative Emission Valve which regulates purging of evaporative vapors.

ON-BOARD REFUELING VAPOR RECOVERY (ORVR)

The ORVR system recovers and stores hydrocarbon fuel vapor that was previously released during refueling. Non ORVR vehicles vent fuel vapors from the tank venting line back to the filler neck and in many states reclaimed by a vacuum receiver on the filling station's fuel pump nozzle.

When refueling, the pressure of the fuel entering the tank forces the hydrocarbon vapors through the tank vent line to the liquid/ vapor separator, through the rollover valve and into the charcoal canister.

The HC is stored in the charcoal canister, and the system can then "breathe" through the DM TL and the air filter.

Liquid/Vapor Separator: Fuel vapors are routed from the fuel tank filler neck through a hose to the Liquid/Vapor Separator (located in the right rear wheel well behind the trim).

The vapors cool when exiting the fuel tank, the condensates separate and drain back to the fuel tank through a return hose (1). The remaining vapors exit the Liquid/ Vapor Separator to the Active Carbon Canister.

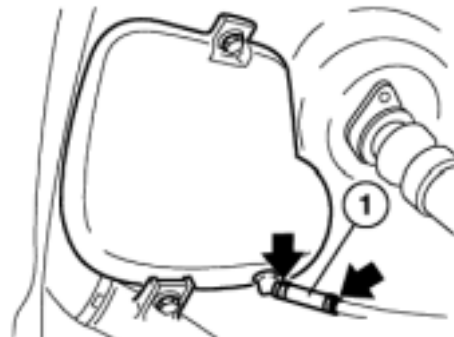

134100143.eps

Active Carbon Cannister: As the fuel vapors enter the canister, they will be absorbed by the active carbon. The remaining air will be vented to the atmosphere through the end of the canister (passing through the DMTL and filter) allowing the fuel tank to “breath”.

When the engine is running, the canister is then "purged" using intake manifold vacuum to draw fresh air through the canister which extracts the hydrocarbon vapors into the combustion chamber. This cleans the canister for additional storage. The Active Carbon Canister is located under the luggage compartment floor with the DM TL Pump.

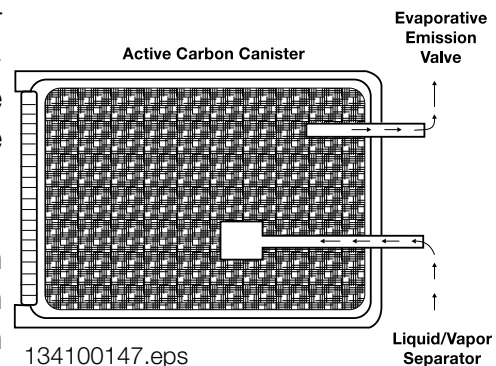

134100147.eps

Evaporative Emission Valve: This ECM controlled solenoid valve (located under the intake manifold) regulates the purge flow from the Active Carbon Canister through the idle air distribution pipe into the intake manifold .

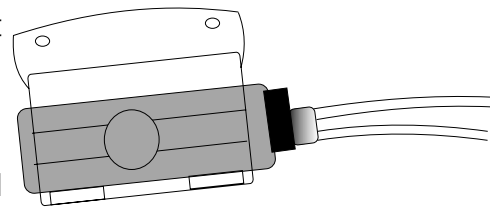

134100101.eps

The ECM Relay provides operating voltage, and the ECM controls the valve by regulating the ground circuit. The valve is powered open and closed by an internal spring.

If the Evaporative Emission Valve circuit is defective, a fault code will be set and the “ENGINE EMISSION” Light will be illuminated. If the valve is “mechanically” defective, a driveability complaint could be encountered and a mixture related fault code will be set.

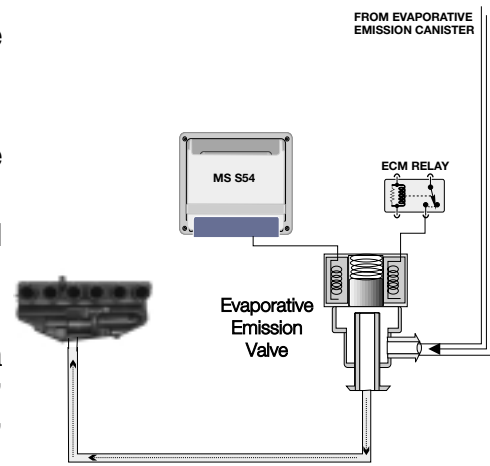

134100100.eps

DMTL (Diagnosis Module - Evaporative Leakage Detection):

This component ensures accurate fuel system leak detection for leaks as small as 1.0 mm (.040”) by slightly pressurizing the fuel tank and evaporative components. The DM TL pump contains an integral DC motor which is activated directly by the ECM. The ECM monitors the pump motor operating current as the measurement for detecting leaks.

The pump also contains an ECM controlled change over valve that is energized closed during a Leak Diagnosis test. The change over valve is open during all other periods of operation allowing the fuel system to “breathe” through the inlet filter. The DM TL is located under the luggage compartment floor with the Active Carbon Cannister.

1. In its inactive state, filtered fresh air enters the evaporative system through the sprung open valve of the DM TL.
2. When the DME activates the DM TL for leak testing, it first activates only the pump motor. This pumps air through a restrictor orifice (1.0 mm) which causes the electric motor to draw a specific amperage value. This value is equivalent to the size of the restrictor.
3. The solenoid valve is then energized which seals the evaporative system and directs the pump output to pressurize the evaporative system.

- A large leak is detected in the evaporative system if the amperage value is not achieved.
- A small leak is detected if the same reference amperage is achieved.
- The system is sealed if the amperage value is higher than the reference amperage.

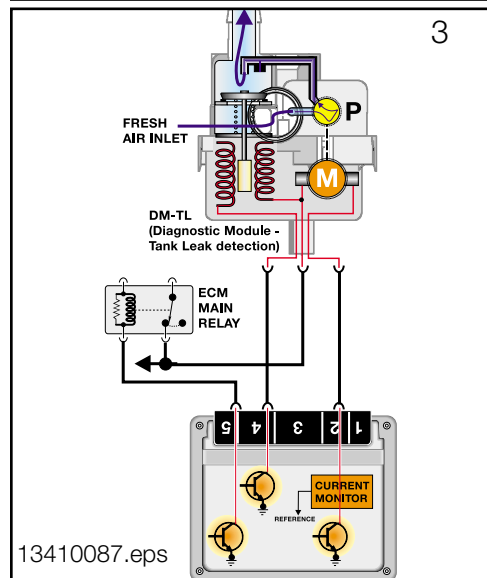
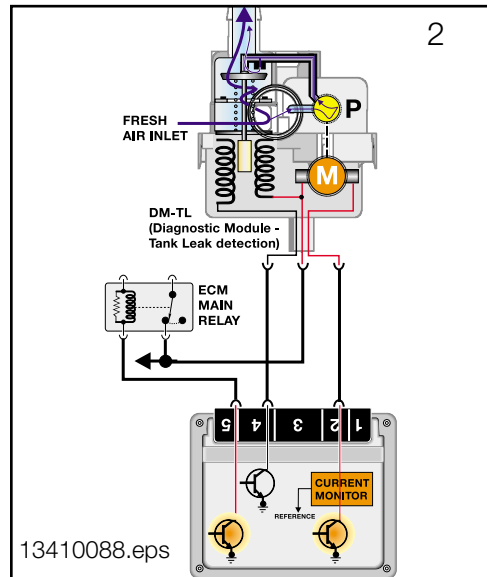
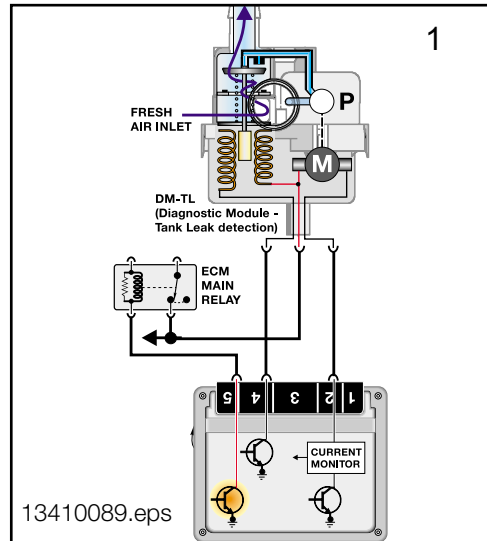

Exhaust Emissions: The combustion process of a gasoline powered engine produces Carbon Monoxide (CO), Hydrocarbons (HC) and Oxides of Nitrogen (NO_x).

- Carbon Monoxide is a product of incomplete combustion under conditions of air deficiency. CO emissions are strongly dependent on the air/fuel ratio.
- Hydrocarbons are also a product of incomplete combustion which results in unburned fuel. HC emissions are dependent on air/fuel ratio and the ignition of the mixture.

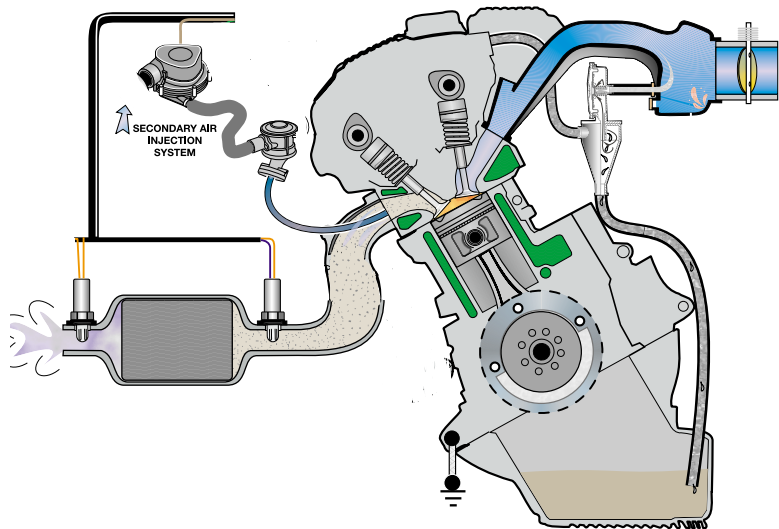

134100103-1.eps

- Oxides of Nitrogen are a product of peak combustion temperature (and temperature duration). NO_x emissions are dependent on internal cylinder temperatures affected by the air/fuel ratio and ignition of the mixture.

Control of exhaust emissions is accomplished by the engine and engine management design as well as after-treatment.

- The ECM manages exhaust emissions by controlling the air/fuel ratio and ignition.
- The ECM controlled Secondary Air Injection further dilutes exhaust emissions leaving the engine and reduces the catalyst warm up time.
- The Catalytic Converter further reduces exhaust emissions leaving the engine.

Bosch LSH 25 Oxygen Sensors: The pre-cat oxygen sensors (1) measure the residual oxygen content of the exhaust gas. The sensors produces a low voltage (0-1000 mV) proportional to the oxygen content that allows the ECM to monitor the air/fuel ratio.

If necessary, the ECM will “correct” the air/fuel ratio by regulating the ms injection time. The sensor is mounted in the hot exhaust stream directly in front of the catalytic converter.

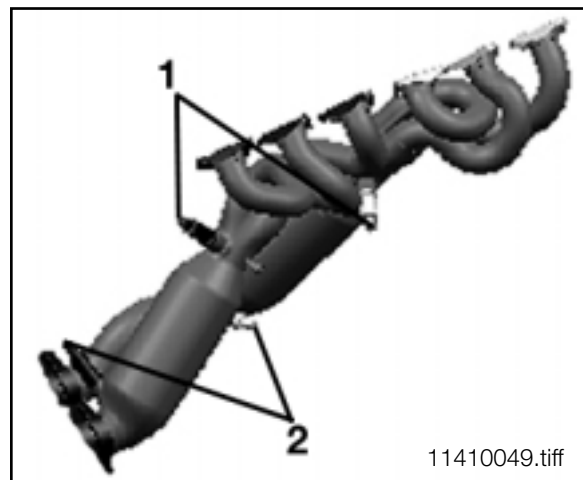

11410049.tiff

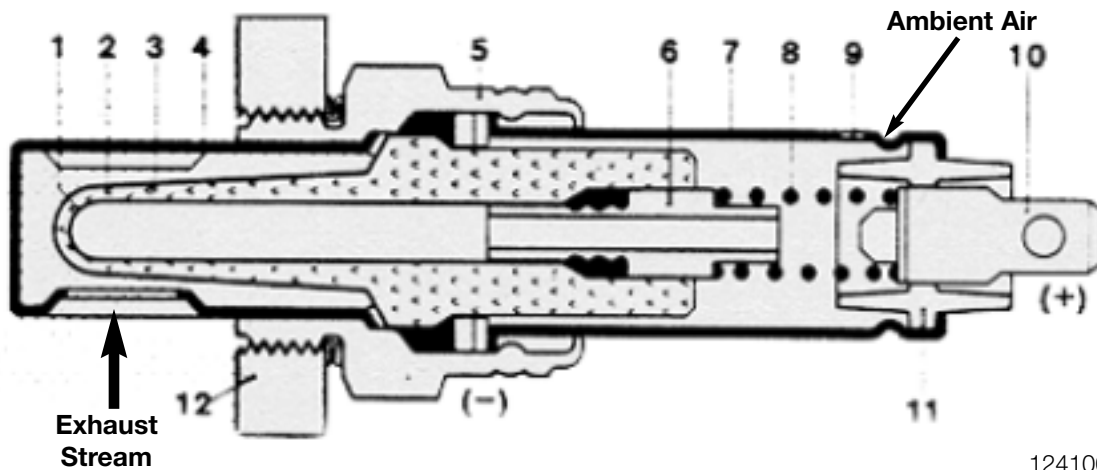

12410005.bmp

1. Electrode (+)	7. External Body (Ventilated)
2. Electrode (-)	8. Contact Spring
3. Porous Ceramic Coating (encasing electrolyte)	9. Vent Opening
4. Protective Metal Cage (Ventilated)	10. Output Lead
5. Casing	11. Insulator
6. Contact Sleeve	12. Exhaust Pipe Wall

The “tip” of the sensor contains a microporous platinum coating (electrodes) which conduct current. The platinum electrodes are separated by solid electrolyte which conducts oxygen ions.

The platinum conductors are covered with a highly porous ceramic coating and the entire tip is encased in a ventilated metal “cage”. This assembly is submersed in the exhaust stream. The sensor body (external) has a small vent opening in the housing that allows ambient air to enter the inside of the tip.

The ambient air contains a constant level of oxygen content (21%) and the exhaust stream has a much lower oxygen content. The oxygen ions (which contain small electrical charges) are “purged” through the solid electrolyte by the hot exhaust gas flow. The electrical charges (low voltage) are conducted by the platinum electrodes to the sensor signal wire that is monitored by the ECM.

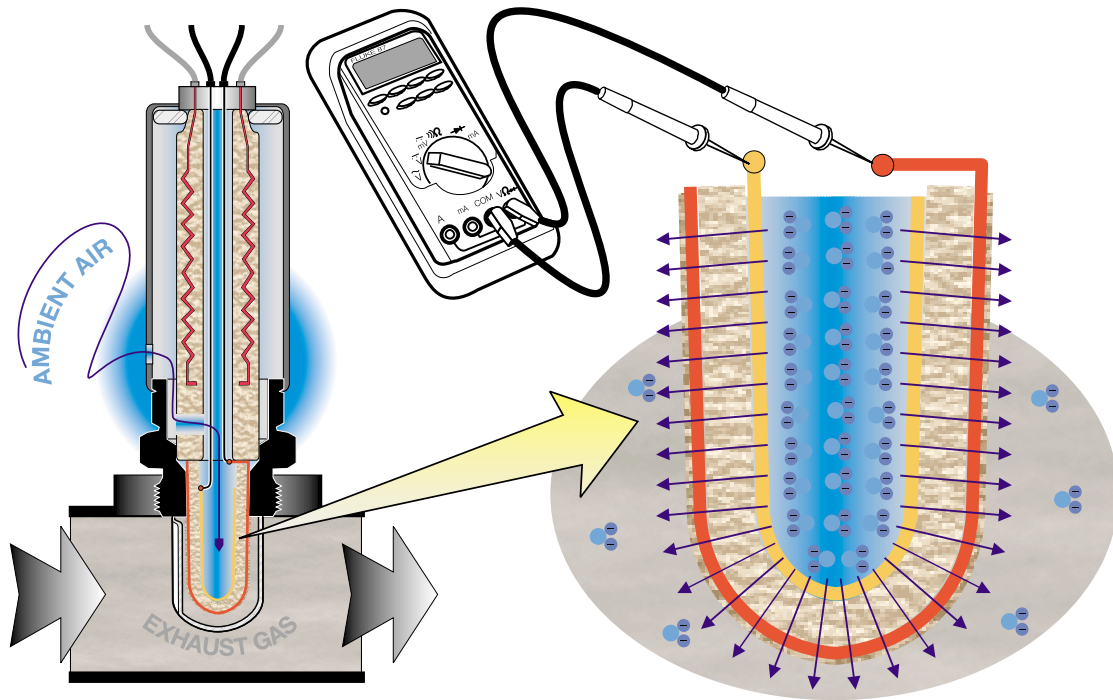

If the exhaust has a lower oxygen content (rich mixture), there will be a large ion “migration” through the sensor generating a higher voltage (950 mV).

If the exhaust has a higher oxygen content (lean mixture), there will be a small ion “migration” through the sensor generating a lower voltage (080 mV).

This voltage signal is constantly changing due to combustion variations and normal exhaust pulsations.

The ECM monitors the length of time the sensors are operating in the lean, rich and rest conditions. The evaluation period of the sensors is over a predefined number of oscillation cycles.

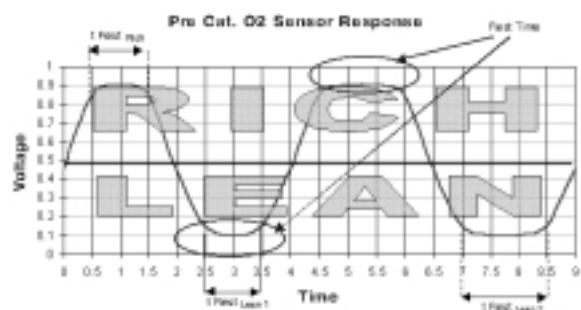

13410092.eps

This conductivity is efficient when the oxygen sensor is hot (250° - 300° C). For this reason, the sensor contains a heating element. This “heated” sensor reduces warm up time, and retains the heat during low engine speed when the exhaust temperature is cooler.

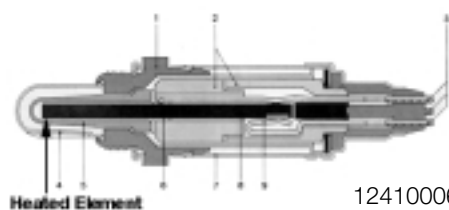

12410006.bmp

Catalytic Converter Monitoring: The efficiency of catalyst operation is determined by evaluating the oxygen storage capability of the catalytic converters using the pre and post oxygen sensor signals.

A properly operating catalyst consumes or stores most of the O₂ (oxygen) that is present in the exhaust gas (input to catalyst). The gases that flow into the catalyst are converted from CO, HC and NO_x to CO₂, H₂O and N₂ respectively.

In order to determine if the catalysts are working correctly, post catalyst oxygen sensors (2) are installed to monitor exhaust gas content exiting the catalysts.

The signal of the post cat. O₂ sensor is evaluated over the course of several pre cat. O₂ sensor oscillations. During the evaluation period, the signal of the post cat. sensor must remain within a relatively constant voltage range (700 - 800 mV).

The post cat. O₂ voltage remains high with a very slight fluctuation. This indicates a further lack of oxygen when compared to the pre cat. sensor. If this signal decreased in voltage and/or increased in fluctuation, a fault code will be set for Catalyst Efficiency and the "ENGINE EMISSION" Light will illuminate.

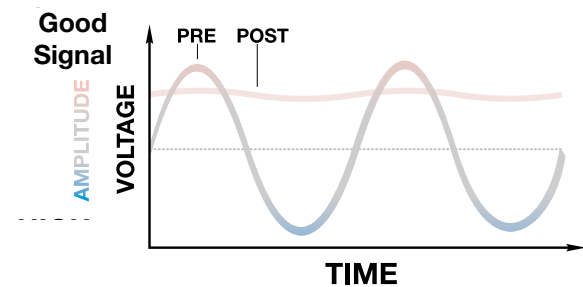
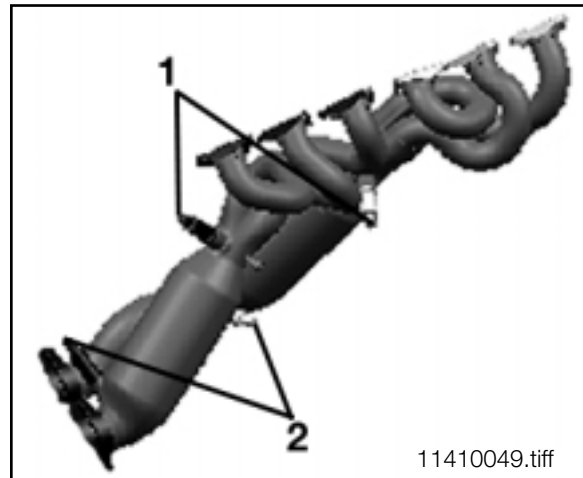

Secondary Air Injection: In order to reduce HC and CO emissions during engine warm up, an electric Air Pump (2) and Air Injection Valve (1) direct fresh air through an internal channel in the cylinder head into the exhaust ports. The Air Injection Valve is opened by air pressure and closed by an internal spring.

Secondary Air injection also provides:

- Reduction in catalyst warm-up time
- Accelerated hydrocarbon Oxidation

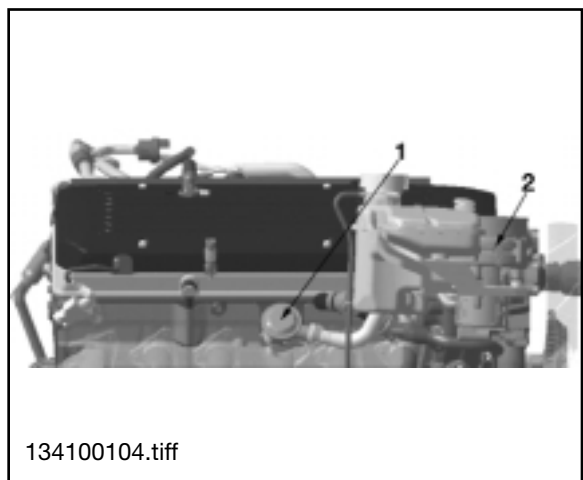

Misfire Detection: As part of the OBD II regulations the ECM must determine misfire and also identify the specific cylinder(s), the severity of the misfire and whether it is emissions relevant or catalyst damaging based on monitoring crankshaft acceleration.

In order to accomplish these tasks the ECM monitors the crankshaft for acceleration by the impulse wheel segments of cylinder specific firing order. The misfire/engine roughness calculation is derived from the differences in the period duration of individual increment gear segments.

Each segment period consist of an angular range of 90° crank angle that starts 54° before Top Dead Center.

If the expected period duration is greater than the permissible value a misfire fault for the particular cylinder is stored in the fault memory of the ECM.

Depending on the level of misfire rate measured the ECM will illuminate the "ENGINE EMISSION" light, deactivate the specific fuel injector to the particular cylinder and switch lambda operation to open-loop.

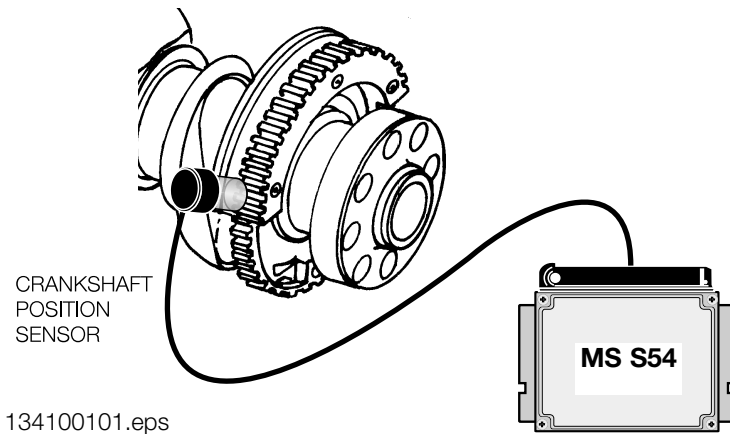

In order to eliminate misfire faults that can occur as a result of varying flywheel tolerances (manufacturing process) an internal adaptation of the flywheel is made. The adaptation is made during periods of decel fuel cut-off in order to avoid any rotational irregularities which the engine can cause during combustion. This adaptation is used to correct segment duration periods prior to evaluation for a misfire event.

If the sensor wheel adaptation has not been completed the misfire thresholds are limited to engine speed dependent values only and misfire detection is less sensitive. The crankshaft sensor adaptation is stored internally and is not displayed via DIS or MoDIC. If the adaptation limit is exceeded a fault will be set.

Principle of Operation

Emissions Management controls evaporative and exhaust emissions. The ECM monitors the fuel storage system for **evaporative leakage** and controls the **purging** of evaporative fuel. The ECM monitors and controls the exhaust emissions by regulating the **combustable mixture** and after treating by injecting **fresh air** into the exhaust system. The catalytic converter further breaks down remaining combustable exhaust gases and is monitored by the ECM for **catalyst efficiency**.

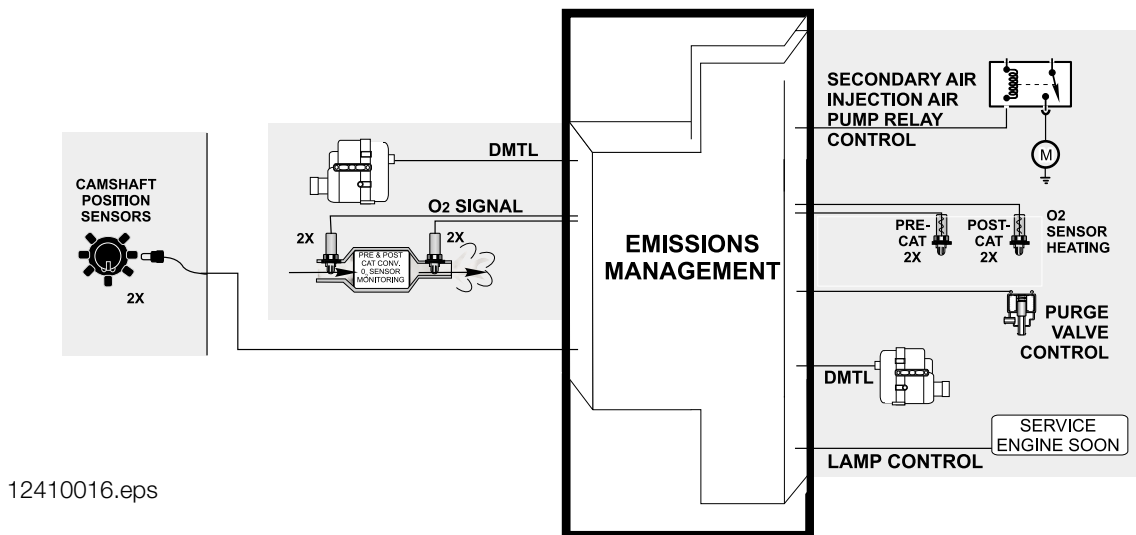

The Evaporative Leakage Detection is performed on the fuel storage system by the DMTL pump which contains an integral DC motor that is activated by the ECM. The ECM monitors the pump motor operating current as the measurement for detecting leaks.

The pump also contains an ECM controlled change over valve that is energized closed during a Leak Diagnosis test. The ECM only initiates a leak diagnosis test every second time the criteria are met. The criteria is as follows:

- Engine **OFF** with ignition switched **OFF**.
- ECM still in active state or what is known as "follow up mode" (ECM Relay energized, ECM and components online for extended period after key off).
- Prior to Engine/Ignition switch OFF condition, vehicle must have been driven for a minimum of 20 minutes.
- Prior to minimum 20 minute drive, the vehicle must have been OFF for a minimum of 5 hours.

-
- Fuel Tank Capacity must be between **15 and 85%** (safe approximation between 1/4 - 3/4 of a tank).
 - Ambient Air Temperature between **-7°C & 35°C** (20°F & 95°F)
 - Altitude **< 2500m** (8,202 feet).
 - Battery Voltage between **11.5 and 14.5 Volts**

When these criteria are satisfied every second time, the ECM will start the Fuel System Leak Diagnosis Test. The test will typically be carried out once a day ie:, once after driving to work in the morning, when driving home in the evening, the criteria are once again met but the test is not initiated. The following morning, the test will run again.

PHASE 1 - REFERENCE MEASUREMENT

The ECM activates the pump motor. The pump pulls air from the filtered air inlet and passes it through a precise 1.0 mm reference orifice in the pump assembly.

The ECM simultaneously monitors the pump motor current flow. The motor current rises quickly and levels off (stabilizes) due to the orifice restriction. The ECM stores the stabilized amperage value in memory. The stored amperage value is the electrical equivalent of a 1.0 mm (0.040") leak.

PHASE 2 - LEAK DETECTION

The ECM energizes the Change Over Valve allowing the pressurized air to enter the fuel system through the Charcoal Canister. The ECM monitors the current flow and compares it with the stored reference measurement over a duration of time.

Once the test is concluded, the ECM stops the pump motor and immediately de-energizes the change over valve. This allows the stored pressure to vent through the charcoal canister trapping hydrocarbon vapor and venting air to atmosphere through the filter.

TEST RESULTS

The time duration varies between 45 & 270 seconds depending on the resulting leak diagnosis test results (developed tank pressure “amperage” / within a specific time period). However the chart below depicts the logic used to determine fuel system leaks.

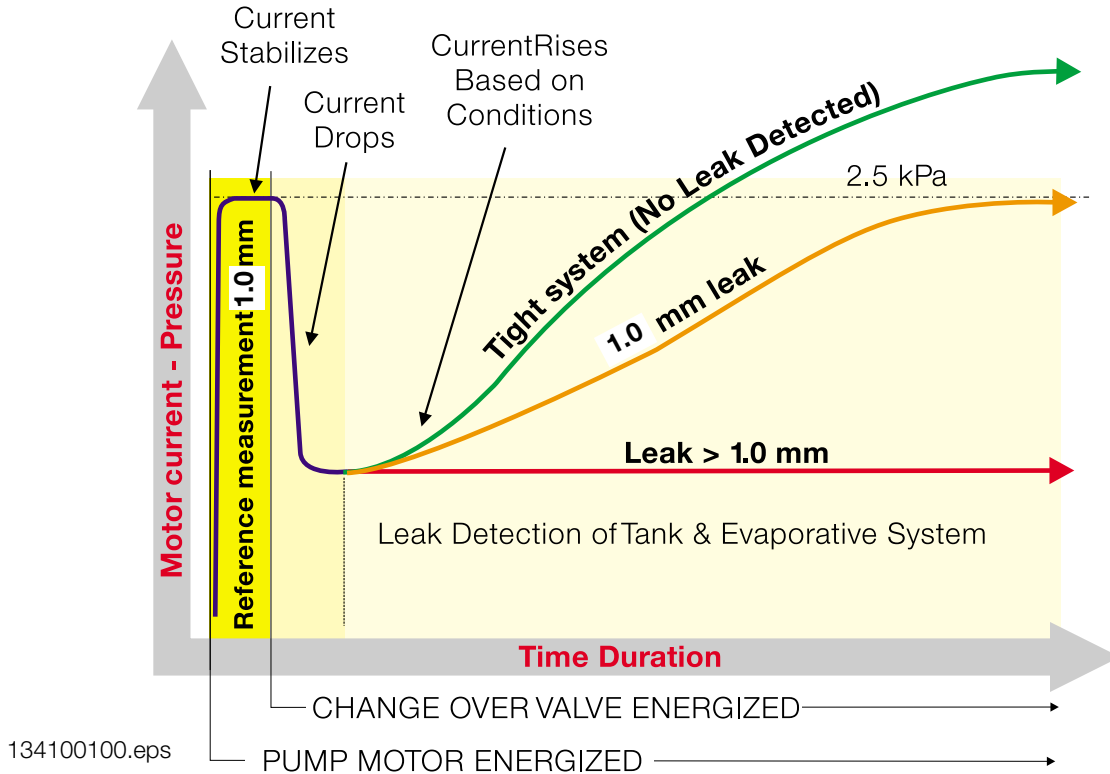

If the ECM detects a leak, a fault will be stored and the “Service Engine Soon” Light will be illuminated. Depending on the amperage measurement detected by the ECM, the fault code displayed will be “small leak” or “large leak”.

If the vehicle was refueled and the filler cap was not properly installed, the “**Check Filler Cap**” message will be displayed.

The ECM detects refueling from a change in the fuel tank sending unit level via the Instrument Cluster. Upon a restart and driving the vehicle, the leakage test will be performed. If the ECM detects leakage, the “**Check Filler Cap**” light will illuminate in the lower left corner of the instrument cluster.

If the filler cap is installed and there is no leakage present the next time the leakage test is performed, the “ENGINE EMISSION” Light will not be illuminated.



62410002.

Evaporative Emission Purging is regulated by the ECM controlling the Evaporative Emission Valve. The Evaporative Emission Valve is a solenoid that regulates purge flow from the Active Carbon Cannister into the intake manifold. The ECM Relay provides operating voltage, and the ECM controls the valve by regulating the ground circuit. The valve is powered open and closed by an internal spring.

The “purging” process takes place when:

- Oxygen Sensor Control is active
- Engine Coolant Temperature is $>60^{\circ}\text{C}$
- Engine Load is present

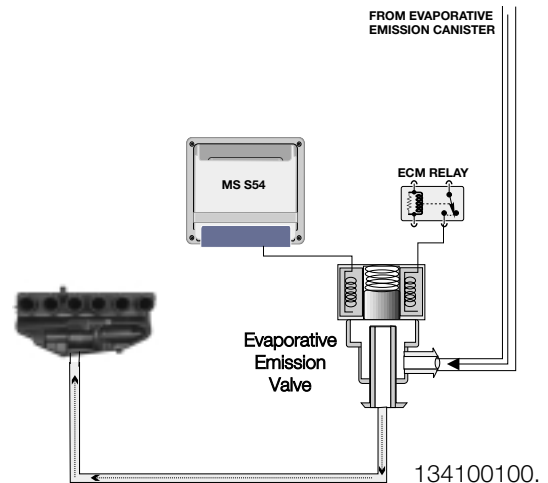

The Evaporative Emission Valve is opened in stages to moderate the purging.

- Stage 1 opens the valve for 10 ms (milli-seconds) and then closes for 150 ms.
- The stages continue with increasing opening times (up to 16 stages) until the valve is completely open.
- The valve now starts to close in 16 stages in reverse order
- This staged process takes 6 minutes to complete. The function is inactive for 1 minute then starts the process all over again.
- During the purging process the valve is completely opened during full throttle operation and is completely closed during deceleration fuel cutoff.

Evaporative Purge System Flow Check is performed by the ECM when the oxygen sensor control and purging is active. When the Evaporative Emission Valve is open the ECM detects a rich/lean shift as monitored by the oxygen sensors indicating the valve is functioning properly.

If the ECM does not detect a rich/lean shift, a second step is performed when the vehicle is stationary and the engine is at idle speed. The ECM opens and close the valve (abruptly) several times and monitors the engine rpm for changes. If there are no changes, a fault code will be set.

Fuel System Monitoring is an OBD II requirement which monitors the calculated injection time (ti) in relation to engine speed, load, and the pre catalytic converter oxygen sensor(s) signals as a result of the residual oxygen in the exhaust stream.

The ECM uses the pre catalyst oxygen sensor signals as a correction factor for adjusting and optimizing the mixture pilot control under all engine operating conditions.

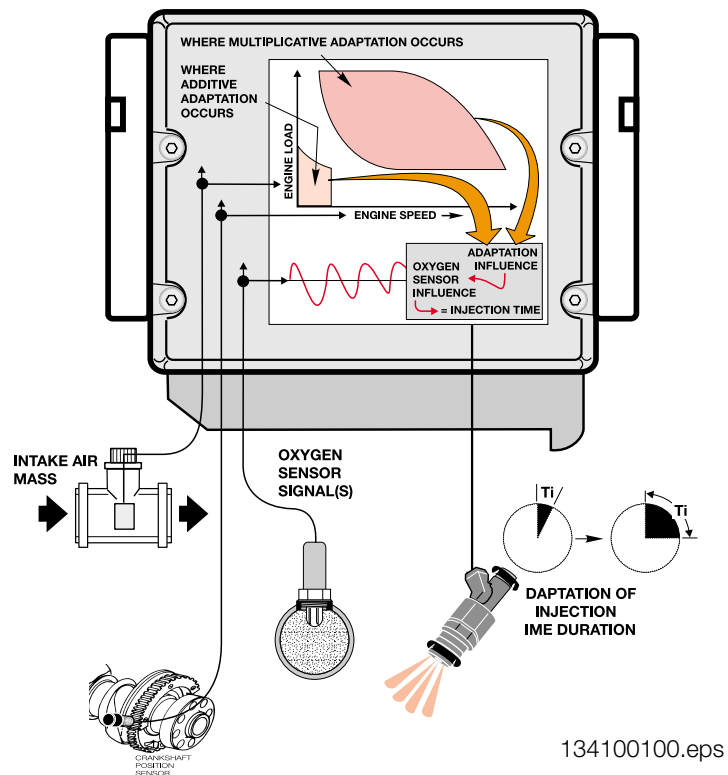

134100100.eps

Adaptation Values are stored by the ECM In order to maintain an "ideal" air/fuel ratio. The ECM is capable of adapting to various environmental conditions encountered while the vehicle is in operation (changes in altitude, humidity, ambient temperature, fuel quality, etc.).

The adaptation can only make slight corrections and can not compensate for large changes which may be encountered as a result of incorrect airflow or incorrect fuel supply to the engine.

Within the areas of adjustable adaption, the ECM modifies the injection rate under two areas of engine operation:

- During idle and low load mid range engine speeds (**Additive Adaptation**),
- During operation under a normal to higher load when at higher engine speeds (**Multiplicative Adaptation**).

These values indicate how the ECM is compensating for a less than ideal initial air/fuel ratio.

NOTE: If the adaptation value is greater than "0.0" Additive (% Multiplicative), the ECM is trying to richen the mixture. If the adaptation value is less then "0.0" Additive (% Multiplicative), the ECM is trying to lean-out the mixture.

Catalyst Monitoring is performed by the ECM under oxygen sensor closed loop operation. The changing air/fuel ratio in the exhaust gas results in lambda oscillations at the pre-catalyst sensors. These oscillations are dampened by the oxygen storage activity of the catalysts and are reflected at the post catalyst sensors as a fairly stable signal (indicating oxygen has been consumed). Conditions for Catalyst Monitoring:

Requirements

Status/Condition

- | | |
|--------------------------------------|----------------------------|
| • Closed loop operation | YES |
| • Engine coolant temperature | Operating Temp. |
| • Vehicle road speed | 3 - 50 MPH (5 to 80 km/h) |
| • Catalyst temperature (calculated)* | 350°C to 650°C |
| • Throttle angle deviation | Steady throttle |
| • Engine speed deviation | Steady/stable engine speed |
| • Average lambda value deviation | Steady/stable load |

* Catalyst temperature is an internally calculated value that is a function of load/air mass and time.

Note: The catalyst efficiency is monitored once per trip while the vehicle is in closed loop operation.

As part of the monitoring process, the pre and post O2 sensor signals are evaluated by the ECM to determine the length of time each sensor is operating in the rich and lean range.

If the catalyst is defective the post O2 sensor signal will reflect the pre O2 sensor signal (minus a phase shift/time delay), since the catalyst is no longer able to store oxygen.

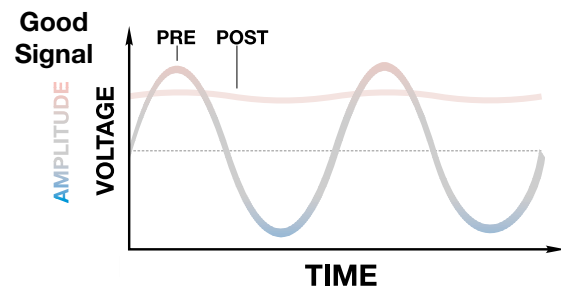

134100104.eps

The catalyst monitoring process is stopped once the predetermined number of cycles are completed, until the engine is shut-off and started again. After completing the next "customer driving cycle" whereby the specific conditions are met and a fault is again set, the "ENGINE EMISSION" light will be illuminated.

Oxygen Sensor Heating is controlled by the ECM to reduce warm up time and retain heat during low engine speed when the exhaust temperature is cooler.

Voltage is supplied from the ECM Relay and the ground circuit is provided by the ECM in pulse width modulation. By pulsing the ground circuit, the oxygen sensor heaters are gradually brought up to temperature. Each oxygen sensor has an individual circuit provided by the ECM.

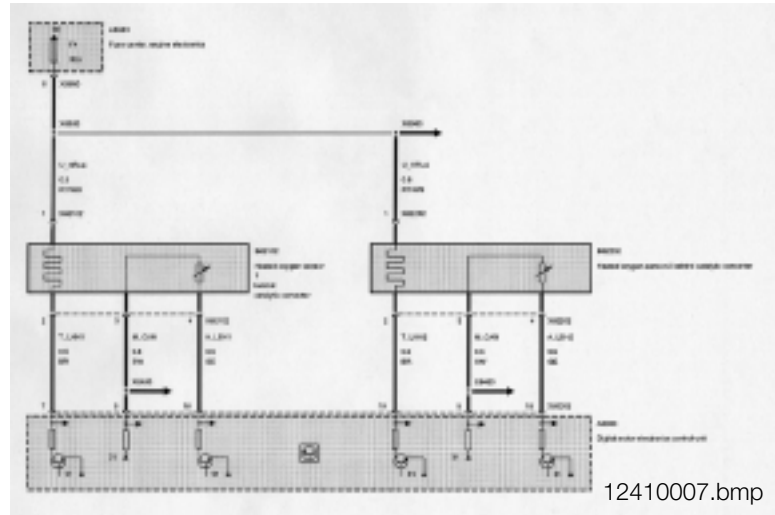

During full throttle operation electrical heating is not required and is deactivated by the ECM.

Oxygen Sensor Heater Monitoring is part of the OBD II requirements requiring all oxygen sensors to be monitored separately for electrical integrity and heater operation. The heater function is monitored continuously while the vehicle is in closed loop operation, during activation by the ECM. An improperly/non operating heater will not allow the sensor signal to reach its predefined maximum and minimum thresholds which can:

- Result in delayed closed loop operation causing an impact on emission levels.
- Result in increased emission levels while in closed loop operation.

As part of the monitoring function for heater current and voltage, the circuit is also checked for an open, short to ground and short to B+ depending on the values of the current or voltage being monitored.

The ECM measures both sensor heater current and the heater voltage in order to calculate the sensor heater resistance and power. If the power of the heater is not within a specified range, a fault will be set. The next time the heater circuit is monitored and a fault is again present the "ENGINE EMISSION" light will be illuminated.

Secondary Air Injection is required to reduce HC and CO emissions while the engine is warming up. Immediately following a cold engine start (-10 to 40°C) fresh air/oxygen is injected directly into the exhaust stream.

The temperature signal is provided to the ECM by the Air Temperature Sensor in the HFM*.

The ECM provides a ground circuit to activate the Secondary Air Injection Pump Relay. The relay supplies voltage to the Secondary Air Injection Pump.

The single speed pump runs for approximately 90 seconds after engine start up.

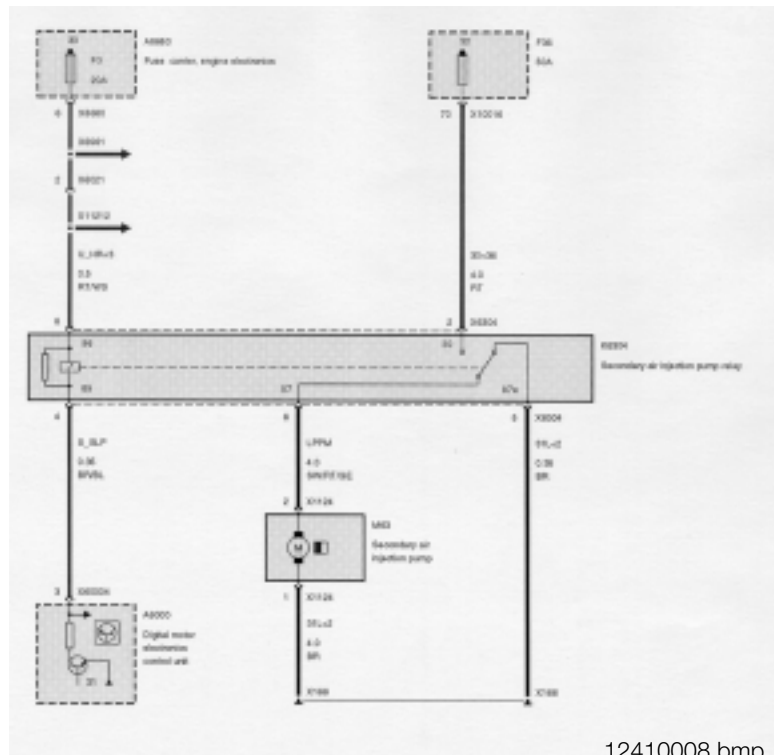

* Below -10° C the pump is activated briefly to “blow out” any accumulated moisture.

Secondary Air Injection Monitoring is performed by the ECM via the use of the pre-catalyst oxygen sensors. Once the air pump is active and is air injected into the exhaust system the oxygen sensor signals will indicate a lean condition.

If the oxygen sensor signals do not change within a predefined time a fault will be set and identify the faulty bank(s). After completing the next cold start and a fault is again present the "ENGINE EMISSION" light will be illuminated.

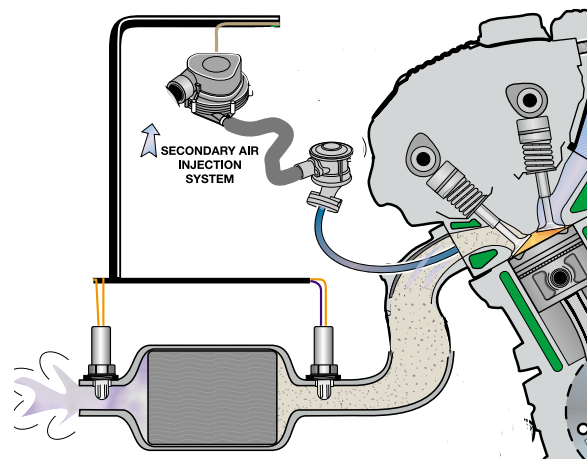

Misfire Detection is part of the OBD II regulations the ECM must determine misfire and also identify the specific cylinder(s), the severity of the misfire and whether it is emissions relevant or catalyst damaging based on monitoring crankshaft acceleration.

Emission Increase:

- Within an interval of 1000 crankshaft revolutions, the ECM adds the the detected misfire events for each cylinder. If the sum of all cylinder misfire incidents exceeds the predetermined value, a fault code will be stored.
- If more than one cylinder is misfiring, all misfiring cylinders will be specified and the individual fault codes for all misfiring cylinders and for multiple cylinder will be stored.

Catalyst Damage:

- Within an interval of 200 crankshaft revolutions the detected number of misfiring events is calculated for each cylinder. The ECM monitors this based on load/rpm. If the sum of cylinder misfire incidents exceeds a predetermined value, a “Catalyst Damaging” fault code is stored and the “ENGINE EMISSION” Light will be illuminated.

If the cylinder misfire count exceeds the predetermined threshold the ECM will take the following measures:

- The oxygen sensor control will be switched to open loop.
- The cylinder selective fault code is stored.
- If more than one cylinder is misfiring the fault code for all individual cylinders and for multiple cylinders will be stored.
- The fuel injector to the respective cylinder(s) is deactivated.

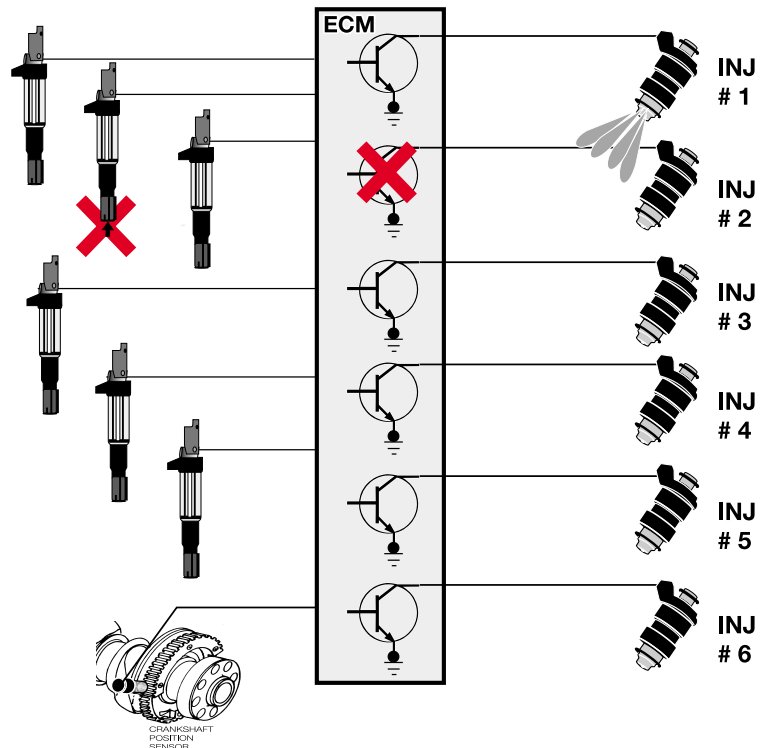

The Integrated Ambient Barometric Pressure Sensor of the MS S54 is part of the ECM and is not serviceable. The internal sensor is supplied with 5 volts. In return it provides a linear voltage of approx. 2.4 to 4.5 volts representative of barometric pressure (altitude).

The MS S54 monitors barometric pressure for the following reasons:

- The barometric pressure signal along with calculated air mass provides an additional correction factor to further refine injection “on” time.
- Provides a base value to calculate the air mass being injected into the exhaust system by the Secondary Air Injection System. This correction factor alters the secondary air injection “on” time, optimizing the necessary air flow into the exhaust system.
- To recognize downhill driving to postpone start of Evaporative Emission Leakage Diagnosis.

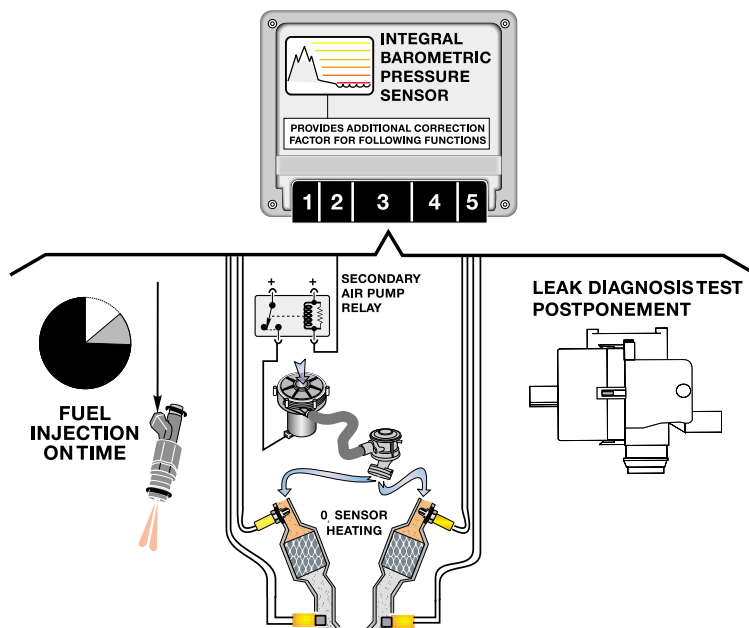

134100105.eps

E46 M3 Diagnostic Socket: For model year 2001 the E46 will eliminate the 20 pin diagnostic connector from the engine compartment. The 16 pin OBD II connector located inside the vehicle will be the only diagnosis port. The 16 pin OBD II connector has been in all BMWs since 1996 to comply with OBD regulations requiring a standardized diagnostic port.

Previously before 2001, only emissions relevant data could be extracted from the OBD connector because it did not provide access to TXD (D-bus). The TXD line is connected to pin 8 of the OBD II connector on vehicles without the 20 pin diagnostic connector.

The cap to the OBD II connector contains a bridge that bridges KL 30 to TXD and TXD II. This is to protect the diagnostic circuit integrity and prevent erroneous faults from being logged.

The OBD II connector is located in the driver's footwell to the left of the steering column.

Special tool 61 4 300 is used to connect to the 20 pin diagnostic lead of the DIS until the introduction of the DISplus.

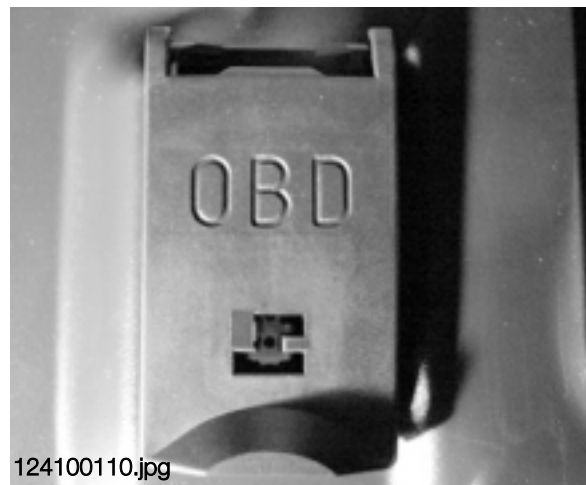

Diagnostics via the OBD II Connector

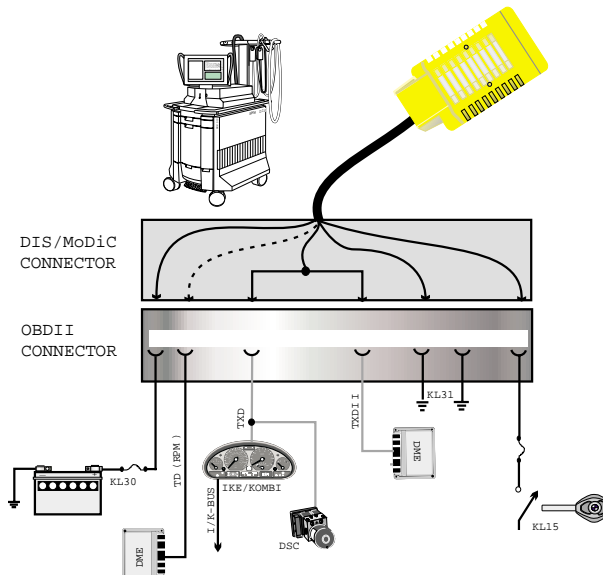

124100108.eps

Workshop Hints

Before any service work is performed on any fuel system related component, always adhere to the following:

- Observe relevant safety legislation pertaining to your area.
- Ensure adequate ventilation
- Use exhaust extraction system where applicable (alleviate fumes).
- **DO NOT SMOKE** while performing fuel system repairs.
- Always wear adequate protective clothing including eye protection.
- Use caution when working around a **HOT** engine compartment.
- BMW does not recommend any **UNAUTHORIZED MODIFICATIONS** to the fuel system. The fuel systems are designed to comply with strict federal safety and emissions regulations. In the concern of product liability, it is unauthorized to sell or perform modifications to customer vehicles, particularly in safety related areas.
- Always consult the **REPAIR INSTRUCTIONS** on the specific model you are working on before attempting a repair.



04410002

Checking Fuel Tank and Ventilation System for Leak-Tightness

Refer to the Repair Information Section 16 00 100 for procedures on testing the fuel tank/ventilation system.

Refer to Service Information Bulletins SI # 04 06 97 and # 04 01 98 for the special tools and adapters to perform the Evaporative Leakage Diagnosis Test.

Tools and Equipment

The DIS/Modic as well as a reputable hand held multimeter can be used when testing inputs/ components.

It is best to make the checks at the ECM connection, this method includes testing the wiring harness.

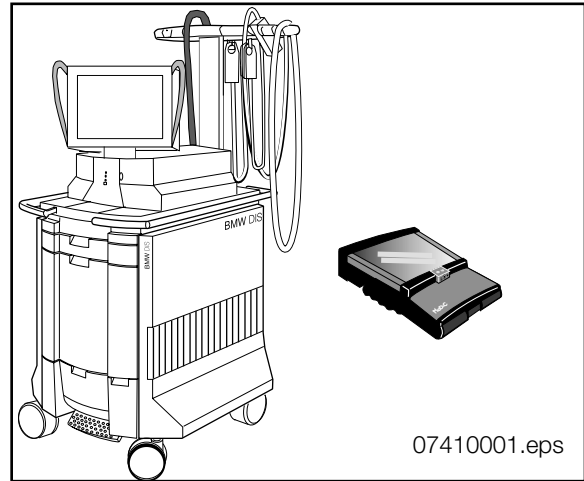

The correct Universal Adapter for the MS S54 application should be used (#90 88 6 121 300). This will ensure the pin connectors and the harness will not be damaged.

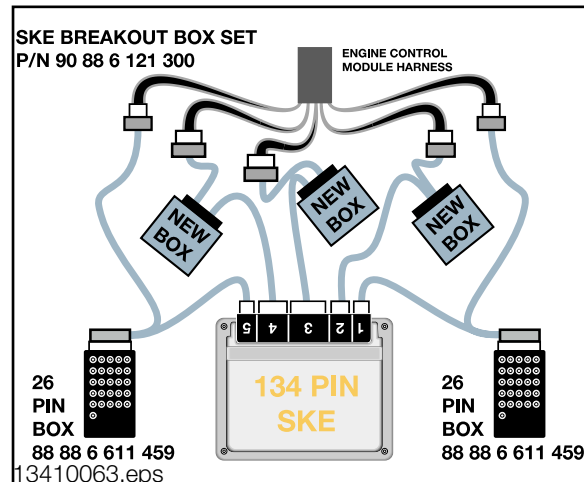

When installing the Universal Adapter to the ECM (located in the Electronics Box in the engine compartment), make sure the ignition is switched off.

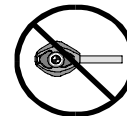

When checking the fuel tank and ventilation system for leak-tightness use Special Tool Set #90 88 6 161 170 which includes all of the pieces shown to the right.

1. Pressure Control Valve
- 2.&3. Quick Coupling Adapters

This set is used in conjunction with shop supplied compressed air and the DIS Multimeter function for reading the pressure bleed off.

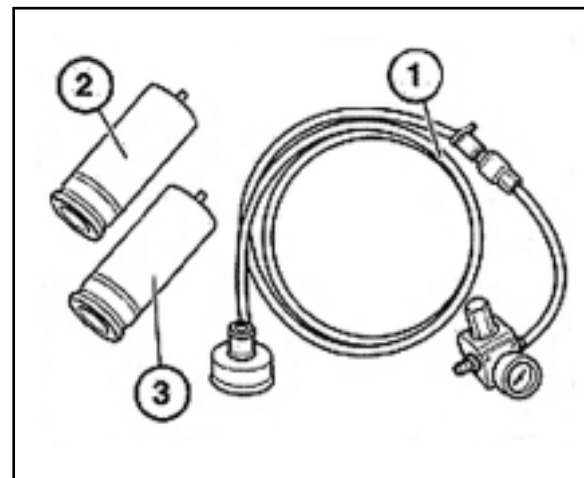

This Special Tool Set #90 88 6 161 160 will also be required to “cap off” the DM TL air filter and Evaporative Emission Valve hose when performing the Leakage Diagnosis Test.

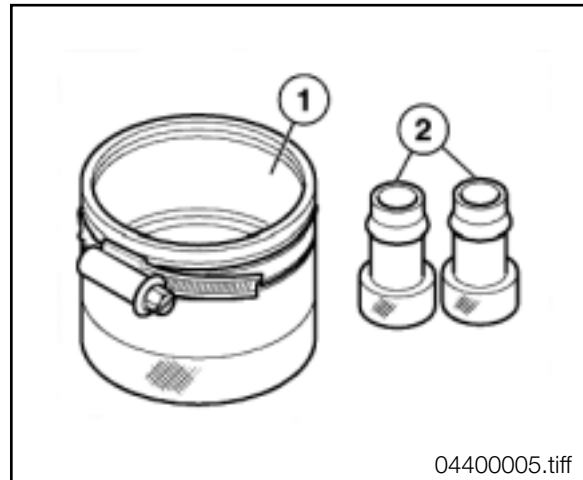

If the test indicates excessive bleed off a leak detector should be used (refer to Repair Instructions) to check for leaks at:

- Fuel Filler Cap and Filler Neck
- Fuel Tank Ventilation Lines
- Evaporative Emission Valve
- Fuel Tank and Fuel Sending Unit
- Liquid/Vapor Separator

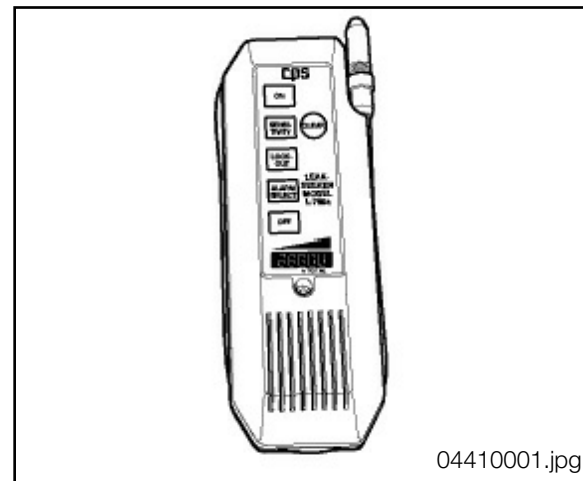

Performance Controls

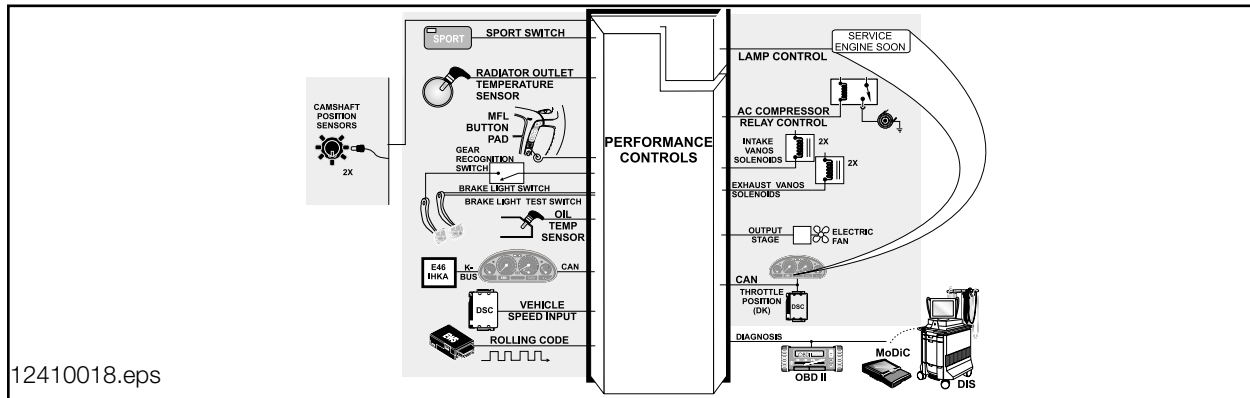

Sport Switch: The MS S54 ECM contains two different throttle progression program curves (Sport and Normal). The sport program is selected by pressing the Sport switch located in the center console switch panel.



The switch provides a ground signal as an input when pressed. The MS S54 activates the sport characteristics for the EDR throttle control. This provides an increase in throttle opening and response time over the non-sport position.

Power Transmission Switch: The power transmission switch (circuit) consists of two switches in series. The circuit includes a clutch switch and a gear selector switch on the transmission. The functions of the power transmission switch are as follows:

- Cutout for cruise control operation
- Enable condition for idle control

The switches provide a high signal for the MS S54 when the clutch is disengaged and the transmission is in gear. If either the clutch is engaged or the transmission is in neutral, the cruise control will be disengaged.

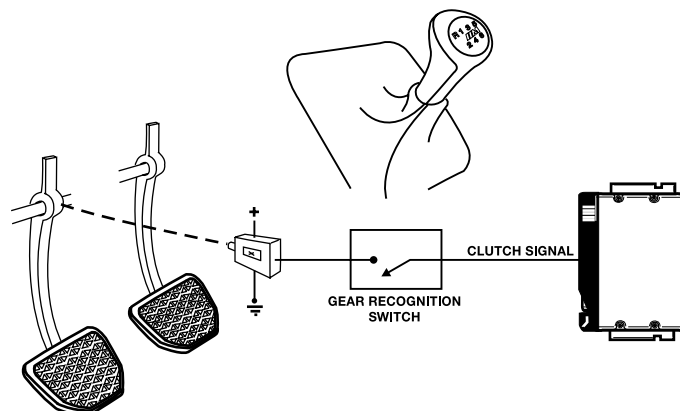

12410051.eps

Cruise Control: As with other EML systems, the MS S54 ECM takes over the function of cruise control. Throttle activation is provided by the MS S54 electronic control of the EDR Actuator and monitoring of the feedback potentiometers.

All driver requested cruise control function requests are provided to the MS S54 from the MFL II control module in the steering wheel over a single FGR data lead.



Oil Temperature/Level Sensor: The electronic level sensor is located in the engine sump mounted to the engine oil pan. The probe of the level sensor contains two temperature sensing elements.

- One senses the engine oil temperature.
- The other is heated to 10° C above the temperature of the engine and then is allowed to cool.

The length of time it takes to cool the heated element is how the sensor determines the engine oil level. When the oil level is high it covers a larger portion of the probe submersed in the oil sump. The engine oil around the probe absorbs the heat of the heated element quicker than if the level is low.

The microprocessor in the base of the sensor produces a pulse width modulated signal proportional to the oil level. The pulse width increases with a decreased level of oil.

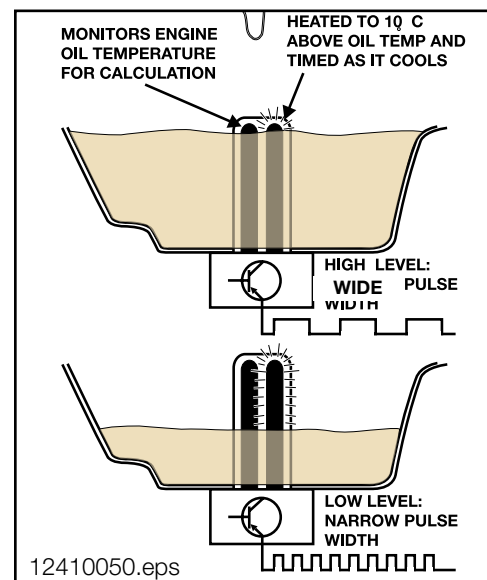

Based on the oil temperature, the visual warning LEDs in the tachometer will illuminate at cold engine start up and slowly be extinguished as the oil temperature increases. One amber and the red LEDs always stay illuminated reminding the driver of maximum rpm zone.

The oil temp sensor also serves as a vital input for VANOS operation, varying the solenoid control based on oil temperature (reaction time of camshaft movement). In the event of a fault the engine coolant temperature is used as a substitute value.

Electric Cooling Fan: The electric cooling fan is controlled by the ECM. The ECM uses a remote power output final stage (mounted on the fan housing). The power output stage receives power from a 50 amp fuse. The electric fan is controlled by a pulse width modulated signal from the ECM.

The fan is activated based on the ECM calculation of:

- Coolant outlet temperature (monitored by the Radiator Outlet Temperature Sensor)
- Calculated (by the ECM) catalyst temperature
- Vehicle speed
- Battery voltage
- Air Conditioning pressure (calculated by IHKA and sent via the K-Bus to the ECM)

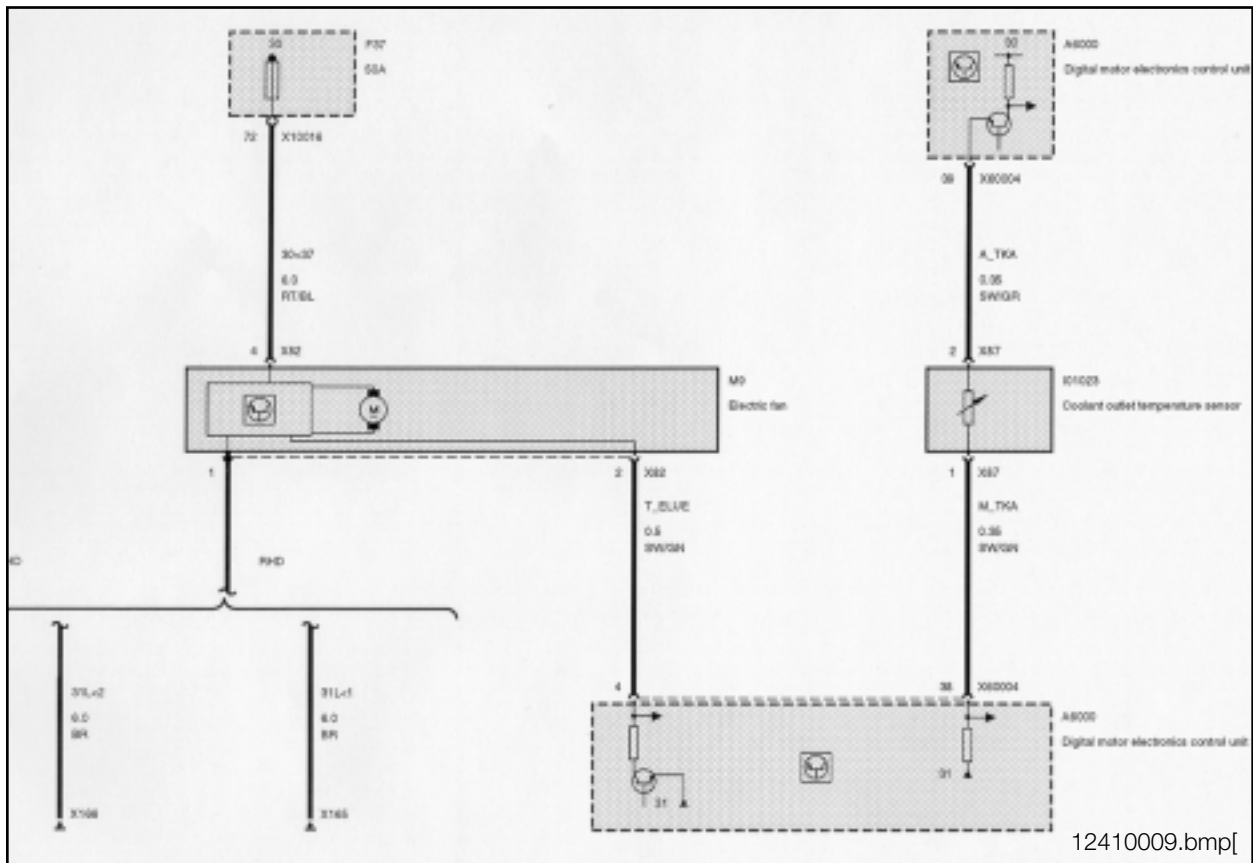

Tools and Equipment

The DIS/Modic as well as a reputable hand held multimeter can be used when testing inputs/components.

It is best to make the checks at the ECM connection, this method includes testing the wiring harness.

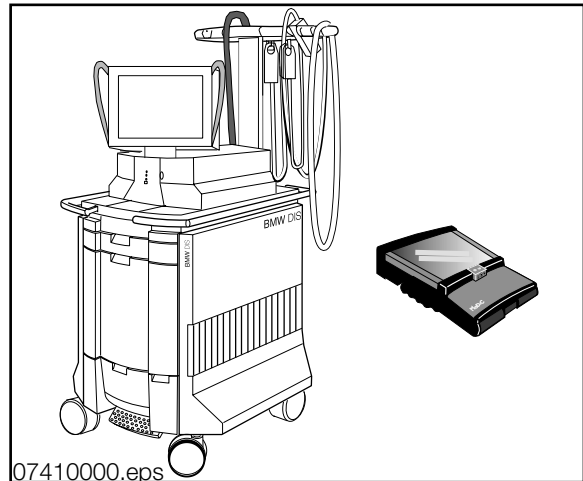

The correct Universal Adapter for the MS S54 application should be used (#90 88 6 121 300). This will ensure the pin connectors and the harness will not be damaged.

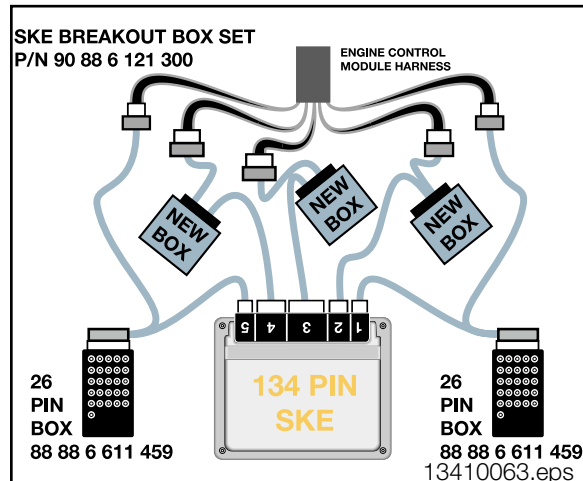

When installing the Universal Adapter to the ECM (located in the Electronics Box in the engine compartment), make sure the ignition is switched off.

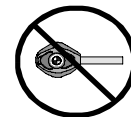

Review Questions

1. Describe the Power Supply for the Fuel Injectors and Ignition Coils: _____

2. Name the Components of the Fuel Supply System:

3. List the inputs required for Fuel Injector operation:

4. Describe the Emission Optimized Function: _____

5. Name two types of Emissions the ECM controls: _____
6. What two sensors are used to monitor throttle movement?

7. Why are there two inputs from the Accelerator Module? _____

8. Where is the Diagnostic Socket located? _____
9. How many speeds will the Secondary Air Injection Pump run at? _____
10. What is the Repair Instruction (number) for the procedure to perform a Leakage Diagnosis Test? _____
11. How is the secondary ignition monitored for misfire? _____

