

**Technical training.**  
**Product information.**

## **F25 Powertrain**



**BMW Service**

Edited for the U.S. market by:  
**BMW Group University**  
**Technical Training**  
ST1106 2/1/2011

# General information

## Symbols used

The following symbol is used in this document to facilitate better comprehension or to draw attention to very important information:



---

Contains important safety notes and information that needs to be observed strictly in order to guarantee the smooth operation of the system.

---

## Information status and national-market versions

BMW Group vehicles meet the requirements of the highest safety and quality standards. Changes in requirements for environmental protection, customer benefits and design render necessary continuous development of systems and components. Consequently, there may be discrepancies between the contents of this document and the vehicles available in the training course.

This document basically relates to left-hand drive vehicles with European specifications. Some controls or components are arranged differently in right-hand drive vehicles than shown in the graphics in this document. Further differences may arise as the result of the equipment variations used in specific markets or countries.

## Additional sources of information

Further information on the individual topics can be found in the following:

- Owner's Handbook
- Integrated Service Technical Application.

©2010 BMW AG, Munich

## Reprints of this publication or its parts require the written approval of BMW AG, München

The information contained in this document form an integral part of the technical training of the BMW Group and are intended for the trainer and participants of the seminar. Refer to the latest relevant information systems of the BMW Group for any changes/additions to the Technical Data.

Status of the information: **July 2010**  
**VH-23/International Technical Training**

# F25 Powertrain

## Contents

<b>1.</b>	<b>Powertrain variants</b> .....	<b>1</b>
1.1.	Models.....	1
1.1.1.	gasoline engines.....	1
1.2.	Further information.....	2
<b>2.</b>	<b>Engines</b> .....	<b>3</b>
2.1.	N52 engine.....	3
2.1.1.	Highlights.....	3
2.1.2.	Technical data.....	3
2.2.	N55 engine.....	3
2.2.1.	Highlights.....	4
2.2.2.	Technical data.....	4
2.2.3.	Full load diagram.....	4
2.3.	Engine designation and engine identification.....	5
2.3.1.	Engine designation.....	5
2.3.2.	Engine identification.....	6
<b>3.</b>	<b>Automatic transmission</b> .....	<b>8</b>
3.1.	Designation.....	8
3.2.	Variants.....	8
3.3.	GA8HP transmission.....	8
3.3.1.	Technical data.....	10
3.4.	Transmission emergency release.....	10
3.4.1.	Mechanical transmission emergency release.....	10
3.4.2.	Electronic transmission emergency release.....	12
3.5.	Gear selector switch.....	13
<b>4.</b>	<b>Drivetrain</b> .....	<b>14</b>
4.1.	System overview.....	14
4.2.	Front axle differential.....	14
4.3.	Transfer case.....	15
4.3.1.	Overview.....	15
4.3.2.	Power flow.....	16
4.3.3.	Power mechanism/multidisc clutch.....	17
4.3.4.	Specific mechanism.....	18
4.3.5.	Service information.....	18
4.4.	Rear axle final drive.....	19
4.4.1.	Highlights.....	20
4.4.2.	Designation.....	20
4.4.3.	Variants.....	21
4.5.	Driveshafts.....	21

# F25 Powertrain

## Contents

4.5.1.	Overview.....	21
4.5.2.	Collapsing element.....	23
4.6.	Output shafts, front axle.....	23
4.6.1.	Overview.....	24
4.7.	Output shafts, rear axle.....	27

# F25 Powertrain

## 1. Powertrain variants

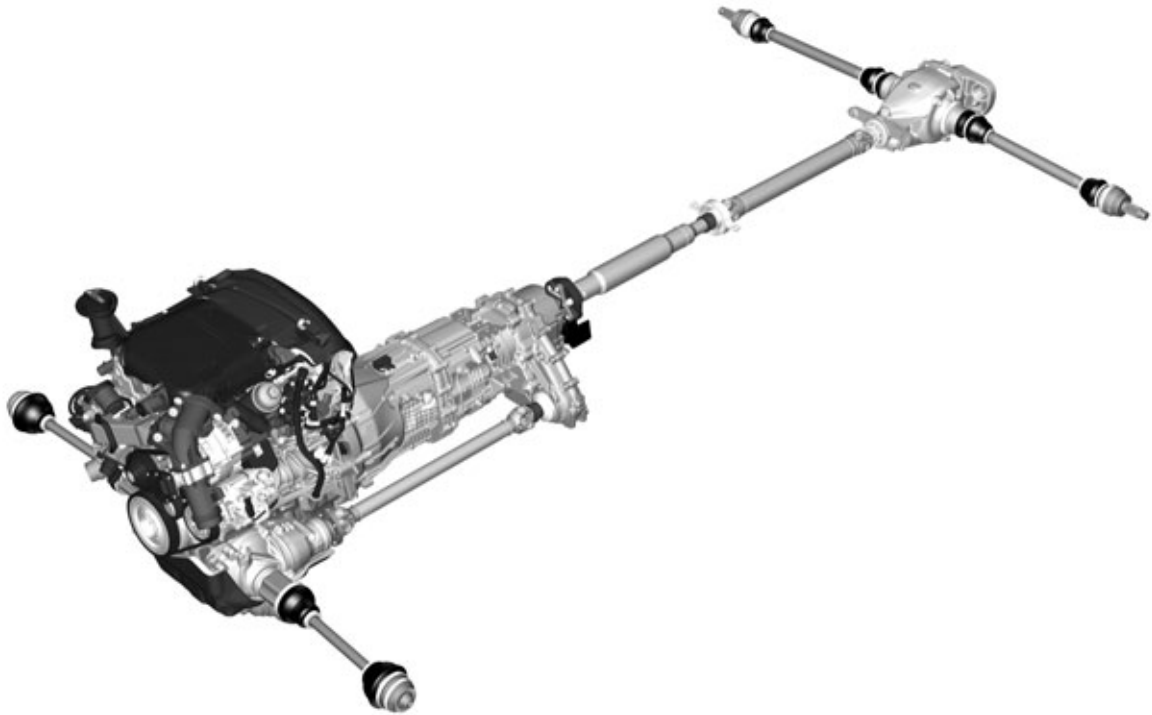

F25 Drive

TF10-1076

### 1.1. Models

The following X3 models are available:

- X3 xDrive28i
- X3 xDrive35i

#### 1.1.1. gasoline engines

		<b>X3 xDrive28i</b>	<b>X3 xDrive35i</b>
Engine		N52B30O2	N55B30M0
Power output	[hp]	258	300
Torque	[Nm/hp]	310/228	400/295
Exhaust emission standards		ULEVII	ULEVII
Automatic transmission		GA8HP45Z	GA8HP45Z

# F25 Powertrain

## 1. Powertrain variants

### 1.2. Further information

The descriptions of the engines and the eight-speed automatic transmission can be found in the following training information:

- Information regarding N52 Engine can be found in the New Engine Technology ST501 training material.
- Information regarding N55 Engine can be found in the N55 engine ST916 training material.
- Information regarding the GA8HP Automatic Transmission can be found in the F10 and F07 training material.

# F25 Powertrain

## 2. Engines

### 2.1. N52 engine

#### 2.1.1. Highlights

- Magnesium-aluminium composite crankcase
- Valvetronic II
- Electric coolant pump
- Three-stage differentiated air intake system
- Magnesium cylinder head cover
- Characteristic-map-regulated oil pump
- Single-belt drive
- Lightweight construction exhaust manifold.

#### 2.1.2. Technical data

		F25, X3 xDrive28i N52B3002	E83, X3 xDrive30i N52B3001
Design		Inline 6	Inline 6
Valves per cylinder		4	4
Engine control		MSV90	MSV80
Displacement	[cm <sup>3</sup> ]	2996	2996
Stroke/bore	[mm]	88.0/85.0	88.0/85.0
Power output at engine speed	[kW/hp] [rpm]	190/240 6600	200/260 6650
Torque at engine speed	[Nm/ft lbs] [rpm]	300/230 2600 – 3000	300/230 2750
Compression ratio	[ε]	10.7 : 1	10.7 : 1
Fuel grade		RON 91 – 98	RON 91 – 98
Exhaust emission standards		ULEV II	ULEV II
Acceleration 0 – 60mph	[s]	6.7	7.0

### 2.2. N55 engine

The N55 engine is the successor to the N54 engine. Technical updates and modifications make it possible to use only one exhaust turbocharger. The technical data have remained virtually the same - with reduced costs and improved quality.

# F25 Powertrain

## 2. Engines

### 2.2.1. Highlights

- Mono exhaust turbocharger (TwinScroll)
- Valvetronic III
- Air-gap-insulated exhaust manifold, six into two; upstream catalytic converter
- Direct fuel injection with central injector location, solenoid valve injectors
- Upstream Digital Engine Electronics (MEVD17.2 Bosch), integrated in differentiated air intake system, FlexRay-compatible
- Lightweight-construction crankshaft
- Characteristic-map-regulated oil pump
- Single-belt drive.

### 2.2.2. Technical data

		F25, X3 xDrive35i N55B30M0	E83, X3 xDrive30i N52B30O1
Design		Inline 6	Inline 6
Valves per cylinder		4	4
Engine control		MEVD17.2	MSV80
Displacement	[cm <sup>3</sup> ]	2979	2996
Stroke/bore	[mm]	89.6/84.0	88.0/85.0
Power output at engine speed	[kW/hp] [rpm]	225/300 5800	200/260 6650
Torque at engine speed	[Nm/ft lbs] [rpm]	400/300 1200 – 5000	300/230 2750
Compression ratio	[ε]	10.2 : 1	10.7 : 1
Fuel grade		RON 91 – 98	RON 91 – 98
Exhaust emission standards		ULEV II	ULEV II
Acceleration 0 – 60mph	[s]	5.5	7.0

### 2.2.3. Full load diagram

When compared with its predecessor, the N55 engine is characterized by lower fuel consumption with identical power and torque data.



# F25 Powertrain

## 2. Engines

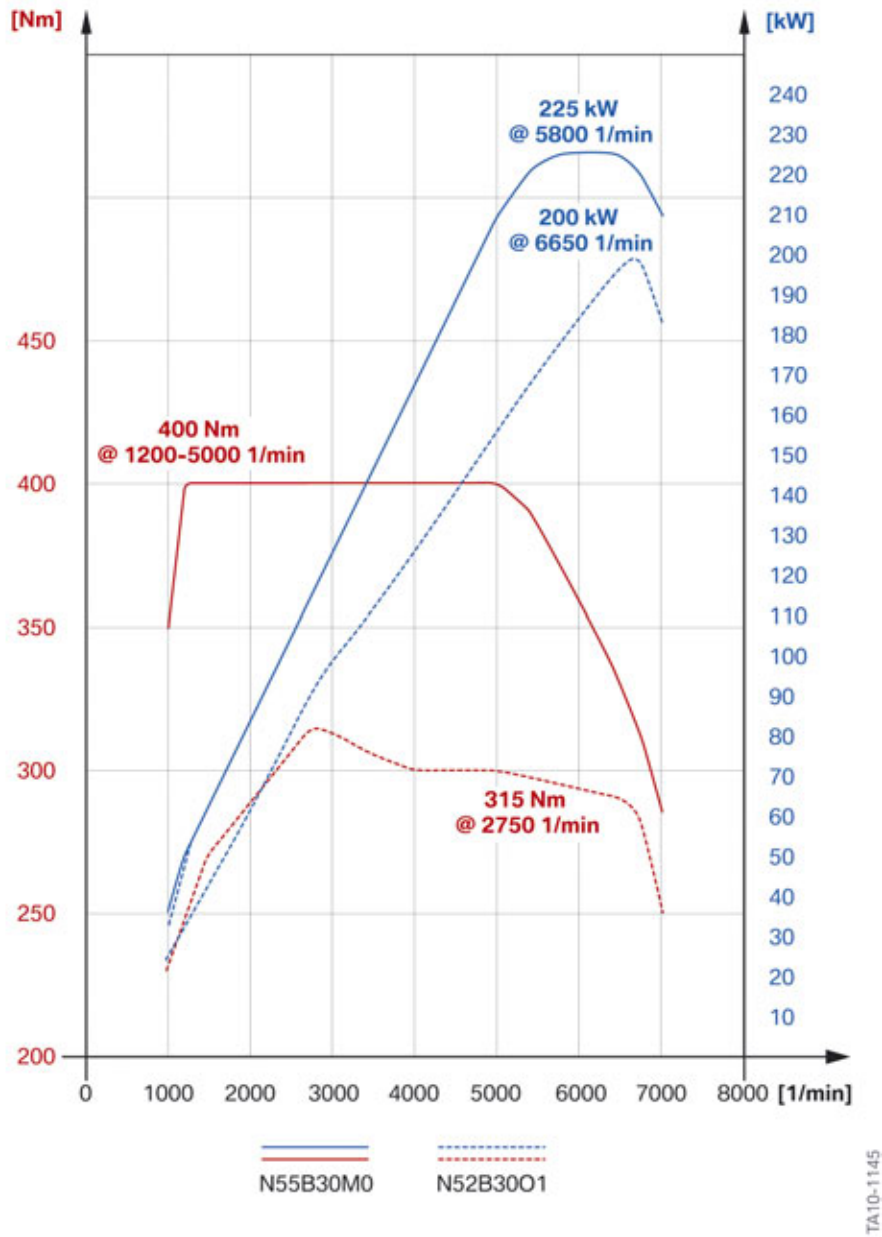

Full load diagram – F25, X3 xDrive35i with N55B30M0 Engine compared with E83, X3 xDrive30i with N52B3001 engine.

### 2.3. Engine designation and engine identification

#### 2.3.1. Engine designation

In the technical documentation, the engine designation is used to ensure unambiguous identification of the engine. In frequent cases, however, only a short designation is used. This short form is used to assign an engine to an engine family.

# F25 Powertrain

## 2. Engines

Position	Meaning	Index	Explanation
1	Engine developer	M, N P S W	BMW Group BMW M Sport BMW M GmbH Bought-in engines
2	Engine type	1 4 5 6 7 8	4-cylinder in-line engine (e.g. N12) 4-cylinder in-line engine (e.g. N43) 6-cylinder in-line engine (e.g. N55) V8 engine (e.g. N63) V12 engine (e.g. N74) V10 engine (e.g. S85)
3	Change to the basic engine concept	0 1 – 9	Basic engine Changes, e.g. combustion process
4	Working method or fuel type and possibly installation position	B D H	gasoline, longitudinally mounted Diesel, longitudinally mounted Hydrogen
5 + 6	Displacement in 1/10 liter	30	3.0 liter
7	Performance class	K U M O T S	Lowest Lower Middle Upper Top Super
8	Revision relevant to approval	0 1 – 9	New development Redesign

### 2.3.2. Engine identification

The engines have an identification mark on the crankcase to ensure proper identification and classification.

This engine identification is also necessary for approval by government authorities. With the N55 engine, this identification has been subject to a further development, with the previous eight positions being reduced to seven. The engine number can be found on the engine below the engine identification. This consecutive number, in conjunction with the engine identification, permits unambiguous identification of each individual engine.

# F25 Powertrain

## 2. Engines

Position	Meaning	Index	Explanation
1	Engine developer	M, N P S W	BMW Group BMW M Sport BMW M GmbH Bought-in engines
2	Engine type	1 4 5 6 7 8	4-cylinder in-line engine (e.g. N12) 4-cylinder in-line engine (e.g. N43) 6-cylinder in-line engine (e.g. N55) V8 engine (e.g. N63) V12 engine (e.g. N74) V10 engine (e.g. S85)
3	Change to the basic engine concept	0 1 – 9	Basic engine Changes, e.g. combustion process
4	Working method or fuel type and possibly installation position	B D H	gasoline, longitudinally mounted Diesel, longitudinally mounted Hydrogen
5 + 6	Displacement in 1/10 liter	30	3.0 liter
7	Type approval matters (changes which require a new type approval)	A B – Z	Standard As required, e.g. RON87

# F25 Powertrain

## 3. Automatic transmission

In the F25, only GA8HP transmission is used. No manual gearbox is currently available.

### 3.1. Designation

A unique designation is used for the transmission in the technical documentation in order to uniquely identify it. In frequent cases, however, only a short designation is used. This abbreviated form is used in order to be able to assign the relevant transmission to a specific transmission family. The transmission family GA8HP which refers to the GA8HP45Z.

Position	Meaning	Index	Explanation
1	Designation	G	Transmission
2	Type of transmission	A	Automatic transmission
3	Number of gears	6 8	Six forward gears Eight forward gears
4	Type of transmission	HP L R	Hydraulic planetary gear train Designation of General Motors Powertrain Designation of General Motors Powertrain
5 + 6	Transferable torque	19 26 32 45 (Zahnradfabrik Friedrichshafen) 45 (General Motors Powertrain) 70 90 390	300 Nm gasoline engine 600 Nm gasoline engine 720 Nm gasoline engine 450 Nm gasoline engine, 500 Nm diesel engine 350 Nm gasoline engine 700 Nm gasoline engine and diesel engine 900 Nm gasoline engine 390 Nm, 4th gear 410 Nm, gasoline engine
7	Manufacturer	G J R Z H	Getrag Jatco General Motors Powertrain Zahnradfabrik Friedrichshafen In-house part

### 3.2. Variants

Model	Engine	Transmission	Torque converter
X3 xDrive28i	N52B30O2	GA8HP45Z	NW235TTD
X3 xDrive35i	N55B30M0	GA8HP45Z	NW235TTD

### 3.3. GA8HP transmission

The F25 features the new automatic transmission GA8HP45Z with eight forward gears and one reverse gear.

# F25 Powertrain

## 3. Automatic transmission

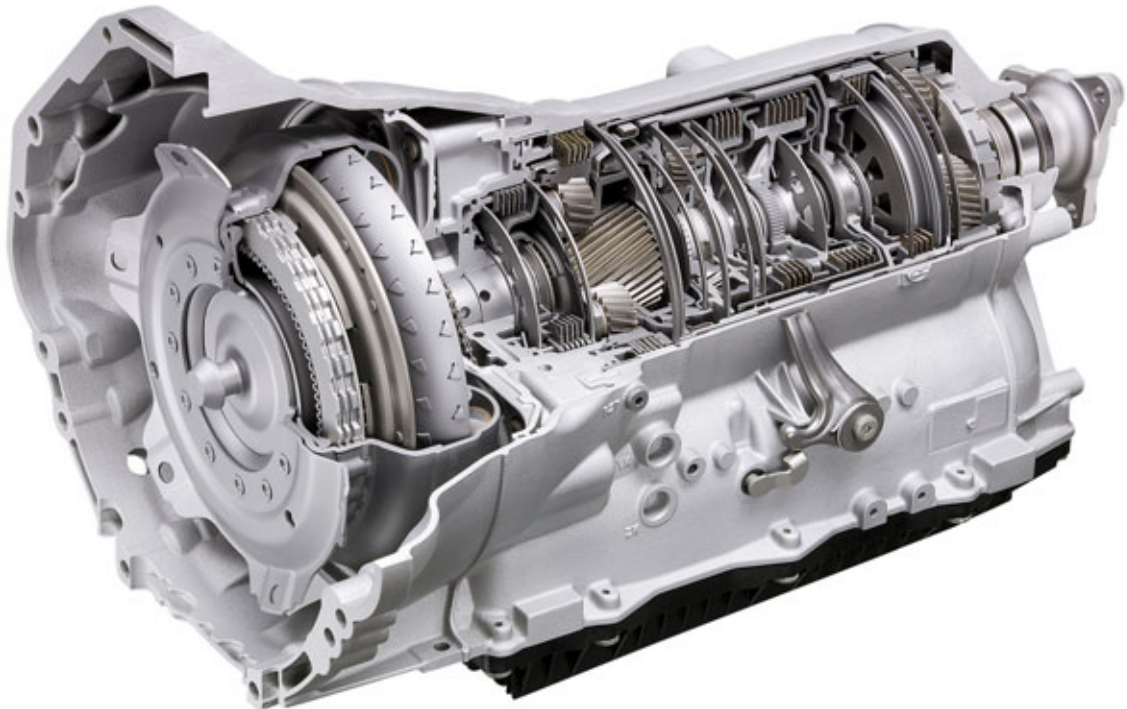

TA09-1361

### Highlights

- Significantly enhanced spontaneity of the gear shifts
- Greater driving and shifting comfort as a result of smaller gear jumps
- Higher control precision of the converter lockup clutch at low engine loads
- High power transmission of the converter lockup clutch
- Reduced fuel consumption (-5 to -6%).

The GA8HP45Z is a new development which will gradually supersede the established GA6HP19Z TU or GA6HP26Z TU 6-speed automatic transmission. The overall gear ratio has been enlarged from 6.04 to 7.07; the gear jumps have become smaller, thus also reducing the differences in speed when shifting gear. The weight of the transmission has been reduced significantly using, among other things, a plastic oil pan.

The Electronic Transmission Control (EGS) control unit is integrated in the control unit framework of the electronic immobilizer EWS. This provides better protection against theft.

It is operated via the gear selector switch.

The torque converter contains second generation mechanical torsional vibration dampers:

- Turbine torsional vibration damper, TTD
- Two-damper torque converter, ZDW.

# F25 Powertrain

## 3. Automatic transmission

The function and design of the converter is described in the Automatic transmission section of ST605 E70 X5 training material.

The vibration isolation reduces the proportion of slip on the converter lockup clutch and enables a larger operating range with the converter lockup clutch closed. This reduces the fuel consumption by 5% to 6% in the consumption cycle (KV01) compared to the TU six-speed automatic transmissions used until now.

### 3.3.1. Technical data

		GA8HP45Z
Maximum power	[kW]	250
Maximum torque	[Nm]	450
Maximum permissible engine speed, 1st - 7th gear	[rpm]	7200
Maximum permissible engine speed, 8th gear	[rpm]	5700
Maximum permissible engine speed, reverse gear	[rpm]	3500
Ratio, 1st gear		4.714
Ratio, 2nd gear		3.143
Ratio, 3rd gear		2.106
Ratio, 4th gear		1.667
Ratio, 5th gear		1.258
Ratio, 6th gear		1.000
Ratio, 7th gear		0.839
Ratio, 8th gear		0.667
Ratio, reverse gear		3.295

### 3.4. Transmission emergency release

The F25 features the new control concept for operation of the mechanical transmission emergency release. The transmission emergency release is no longer operated from the passenger compartment.

#### 3.4.1. Mechanical transmission emergency release



The mechanical transmission emergency release may only be operated by specially trained Service personnel.

In order to operate the mechanical transmission emergency release, the vehicle must be raised and the underbody panelling removed.

# F25 Powertrain

## 3. Automatic transmission

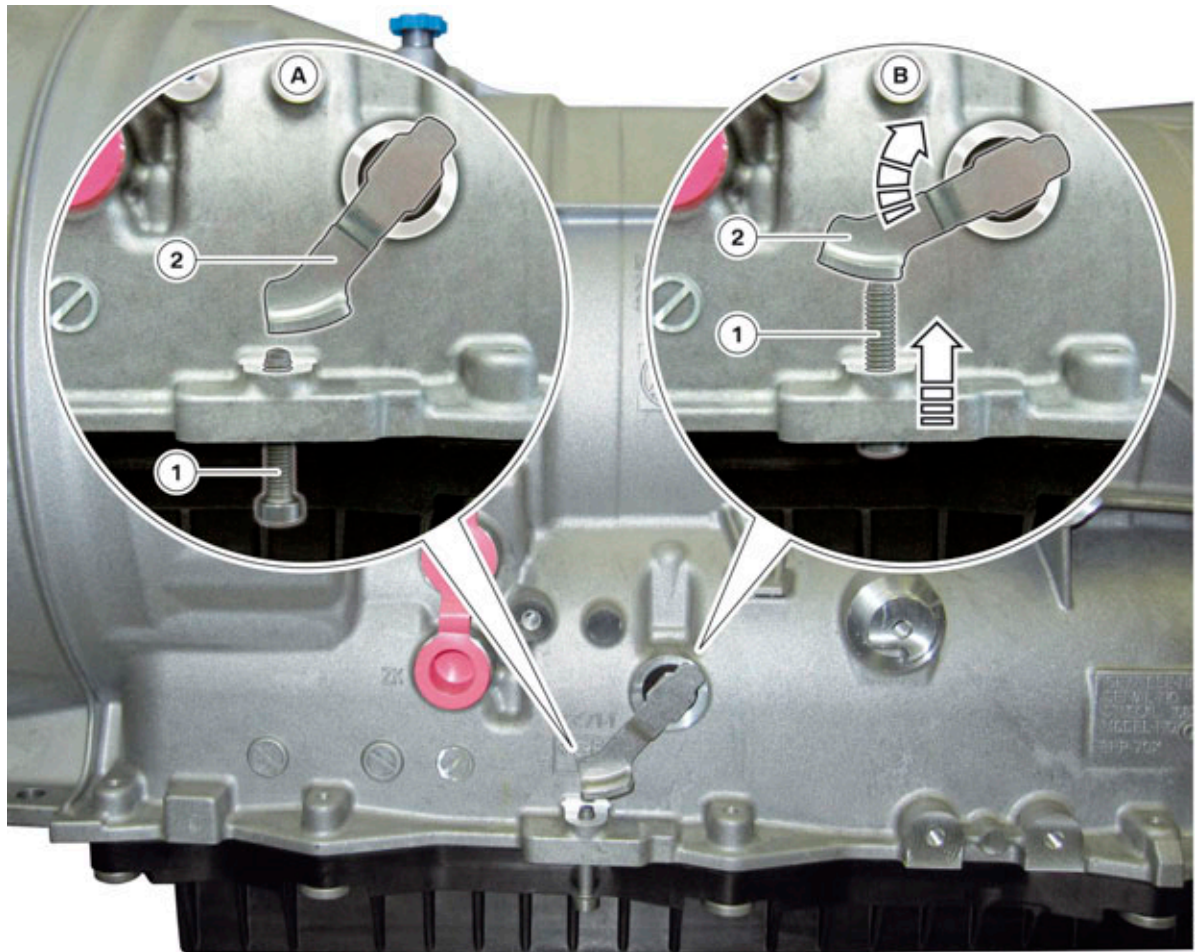

F25 Mechanical transmission emergency release, GA8HP

Index	Explanation
1	Adjusting screw
2	Parking lock lever
A	Transmission parking lock engaged
B	Transmission parking lock released

In the event of a fault, the engaged automatic transmission parking lock can be disabled via a mechanical transmission emergency release function from the vehicle underbody via an adjusting screw.

For detailed information on the mechanical transmission emergency release, refer to the corresponding repair instructions.

# F25 Powertrain

## 3. Automatic transmission

### 3.4.2. Electronic transmission emergency release



The electronic transmission emergency release may only be operated by specially trained Service personnel.

If the electronic transmission emergency release is operated, the vehicle must only be maneuvered and not towed. In the event of misuse, an entry is made in the fault memory.



The electronic transmission emergency release can only be used if the engine does not start but the starter still cranks.

The electronic transmission emergency release is only active for fifteen minutes. As soon as a wheel speed signal is detected, the time extended an additional fifteen minutes. After this period elapses, the parking lock is engaged without a Check Control message being displayed. The specified time depends on the condition of the battery.

- Before operating the electronic transmission emergency release, secure the vehicle to prevent it from rolling
- Depress and hold the brake pedal throughout the entire process
- Press the start/stop button - the starter motor will crank for a specific amount of time



F25 Electronic transmission emergency release, GA8HP

Index	Explanation
1	Release button
2	Gear selector switch



# F25 Powertrain

## 3. Automatic transmission

- Press the shifter release button (1) and hold it pressed
- Move gear selector switch (2) forwards one step (not all the way) and hold it there for **two seconds** (no more, no less)
- Release the gear selector switch (2) and move it forwards again briefly one step (not all the way)  
When the transmission position "N" is displayed in the instrument panel (KOMBI) - the transmission is unlocked electronically



If the start/stop button is pressed again, the parking lock is reactivated without a Check Control message being displayed.

For detailed information on the electronic transmission emergency release, refer to the corresponding repair instructions.

### 3.5. Gear selector switch

The F25 gear selector switch is similar to the F10.



F25 Gear selector switch

Index	Explanation
1	Gear selector switch, Steptronic automatic transmission
2	Gear selector switch, Steptronic sports automatic transmission (SA 2TB)

# F25 Powertrain

## 4. Drivetrain

### 4.1. System overview

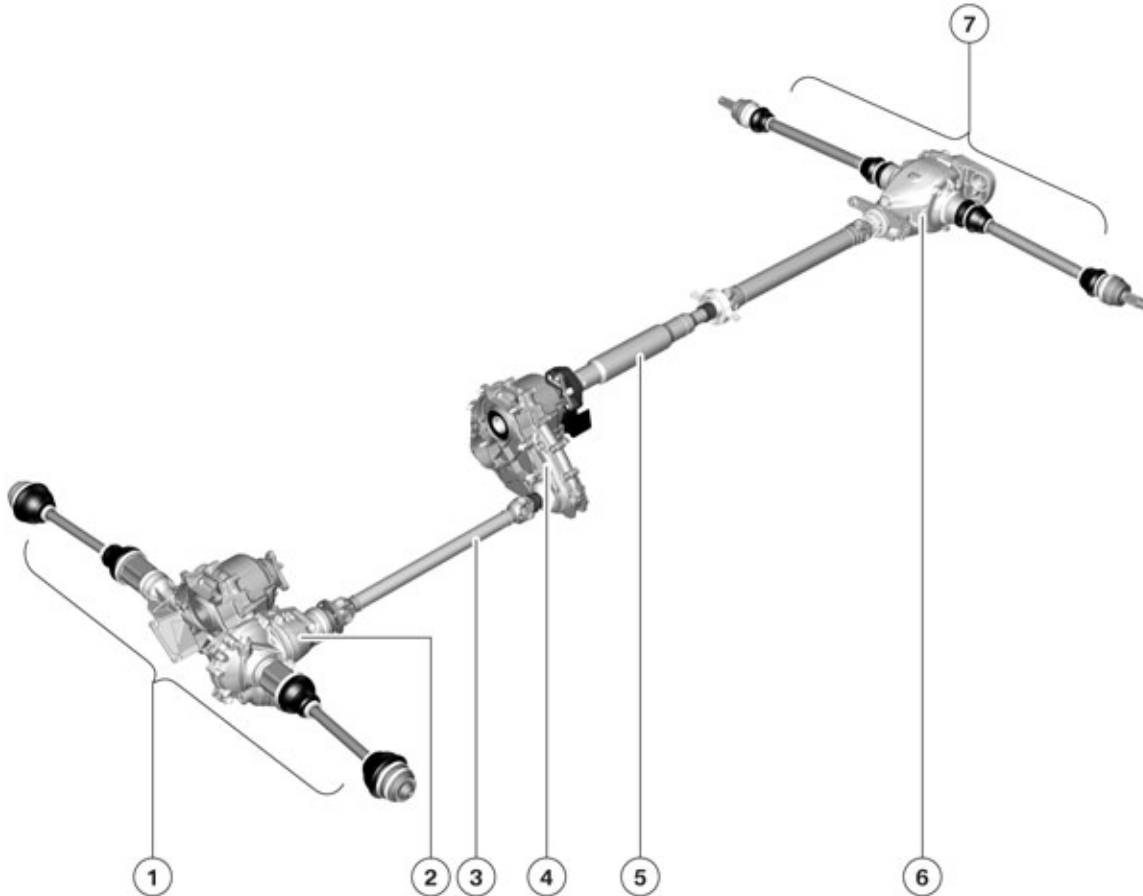

TA10-1080

F25 Drivetrain

Index	Explanation
1	Front output shafts
2	Front axle differential
3	Front driveshaft
4	Transfer case
5	Rear driveshaft
6	Rear axle final drive
7	Rear output shafts

### 4.2. Front axle differential

The established front axle differential VAG 170AL is used for all engine/transmission versions.

The gear ratio of the front axle differential is always the same as the gear ratio of the corresponding rear axle final drive.

# F25 Powertrain

## 4. Drivetrain

Model	Transmission	Front axle differential	Gear ratio $i$
X3 xDrive28i	GA8HP45Z	170AL	3.730
X3 xDrive35i	GA8HP45Z	170AL	3.380

### 4.3. Transfer case

#### 4.3.1. Overview

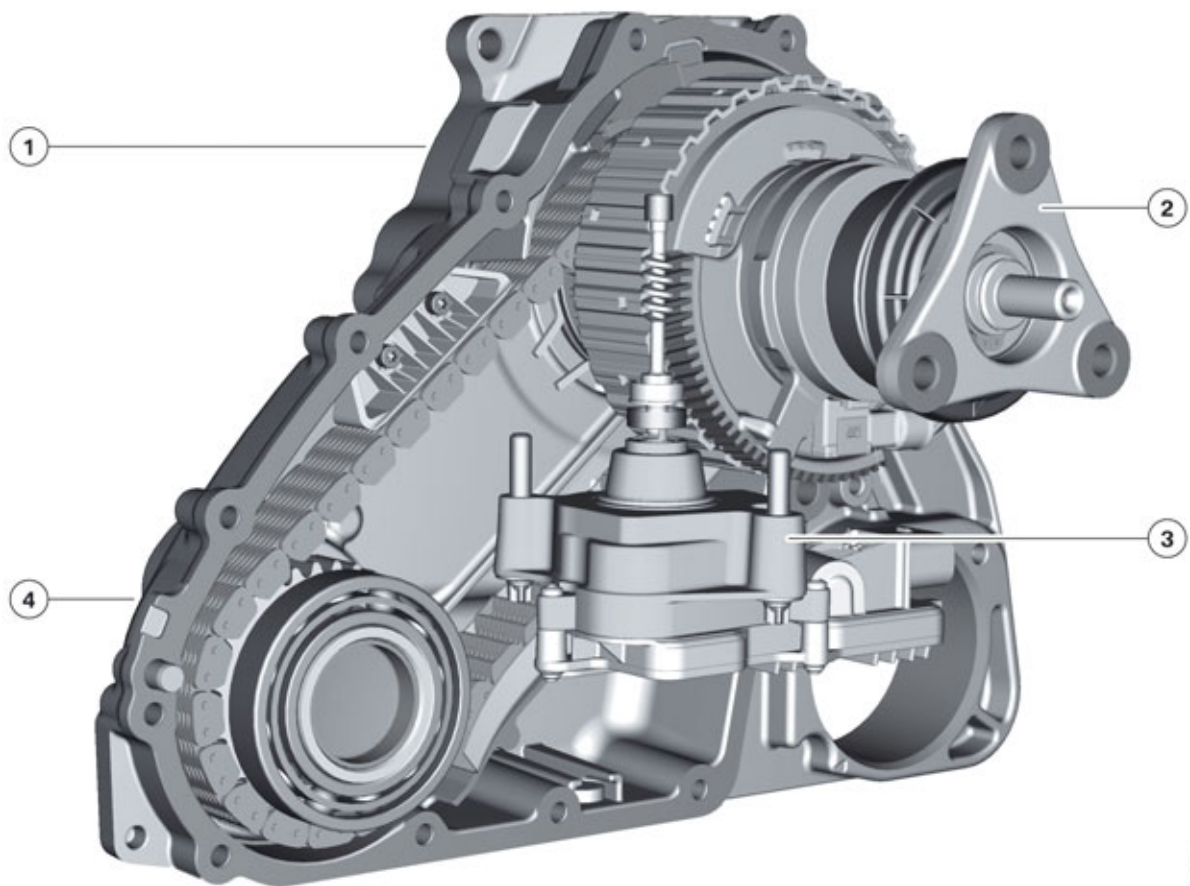

TF10-0423

Mechanical design of ATC 450 transfer case

Index	Explanation
1	Connection to the transmission
2	Connection to rear axle
3	Transfer case (VTG) control unit (for actuation of multidisc clutch)
4	Connection to front axle

# F25 Powertrain

## 4. Drivetrain

The ATC450 transfer case is a further development of the ATC 400 used in the predecessor E83.

### Highlights

- Approx. 2 kg weight reduction
- Optimized efficiency
- Cost efficient.

The overall efficiency has been improved through the following:

- Integration of printed circuit board and servomotor in the transfer case (VTG) control unit
- Omission of mechanical oil pump
- Lubrication and cooling of components via the oil supply function of the chain drive
- Reduction in number of components of actuator mechanism
- minimization of mechanical tolerances.

### 4.3.2. Power flow

The Dynamic Stability Control (DSC) activates the fully-variable torque distribution between the front axle differential and rear axle final drive. The required nominal torque at the multidisc clutch of the transfer case is adjusted via the integrated control unit of the transfer case (VTG). This process is subject to correction functions in relation to the wear and run-in behavior in order to ensure optimum positioning accuracy throughout the entire service life. Continuous ongoing calculation of thermal loading models in the control unit of the transfer case (VTG) protect the transfer case from destruction as a result of overheating.

The variable distribution of torque to the front axle is superimposed on the rigid through drive to the rear axle.

When the multidisc clutch is open, the entire drive torque is transmitted to the rear axle final drive (0/100%). If the multidisc clutch in the transfer case is activated, the drive torque will normally be distributed between the front and rear axle according to the BMW-typical characteristic (40/60%).

Due to the xDrive functionality in the DSC, the torque distribution between axles can also be varied arbitrarily depending on the driving conditions (in response to different road surface coefficients of friction). For more information on the xDrive functionality, refer to the "F25 chassis and suspension training material.

# F25 Powertrain

## 4. Drivetrain

### 4.3.3. Power mechanism/multidisc clutch

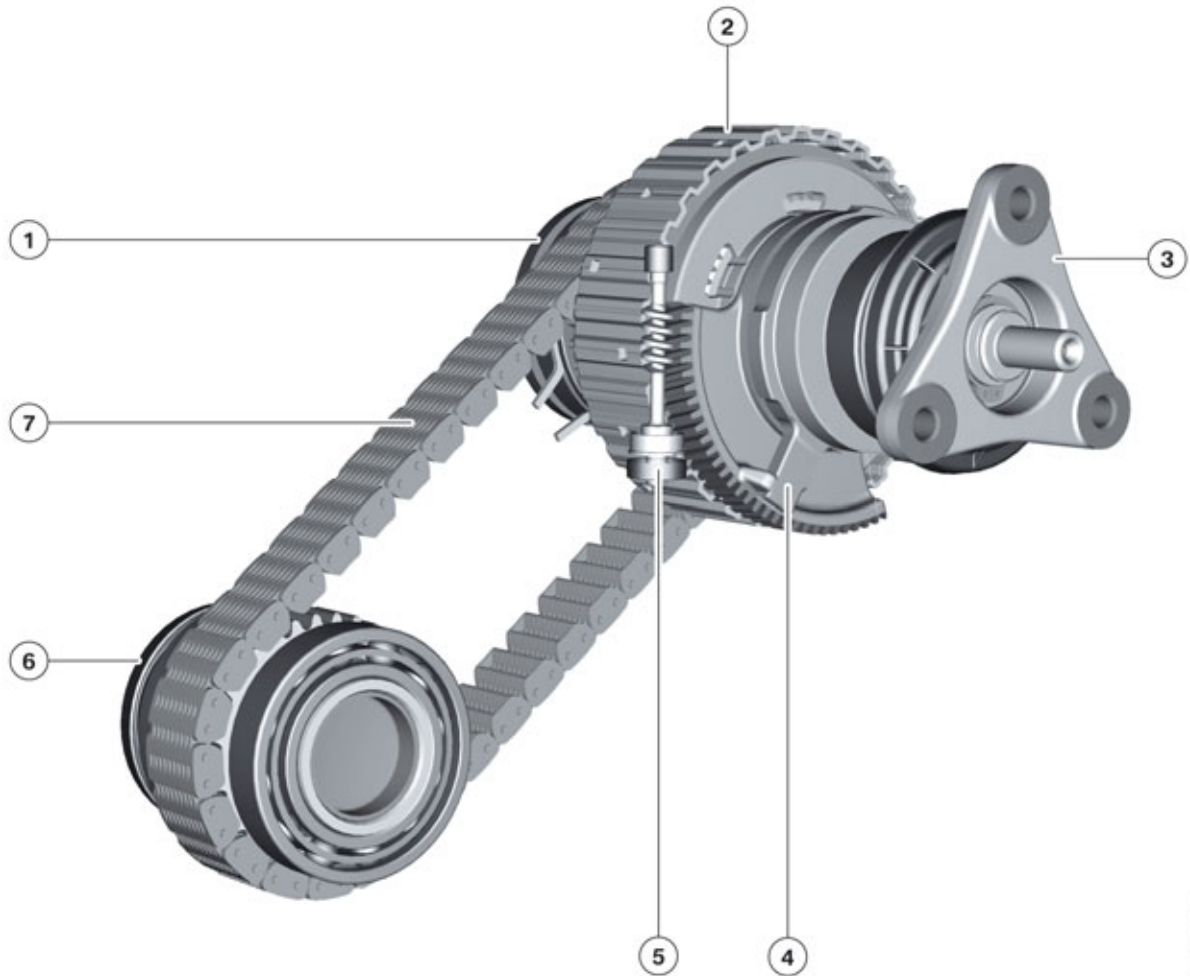

TF10-0424

Power mechanism/multidisc clutch of ATC 450 transfer case

Index	Explanation
1	Connection to the transmission
2	Multidisc clutch
3	Connection to rear axle
4	Actuator ring with ball ramp and external splines
5	Actuator worm gear and wheel
6	Connection to front axle
7	Chain drive between rear and front axle, if multidisc clutch is closed

The transfer case (VTG) control unit module, consisting of electric motor and control unit PCB, transfers the torque to the toothed actuator ring (4) via the worm gear wheel shaft (5). This in turn converts the torque into an axial force via the ball ramp system which compresses the multidisc clutch set (2) via a piston. The higher the applied axial force is, the more torque is diverted from the main gear (1) via the chain drive (7) to the front axle flange (6) and the front axle.

# F25 Powertrain

## 4. Drivetrain

If the multidisc clutch is fully open, the entire input torque is transmitted to the rear axle flange (3) via the direct connection driveshaft.

### 4.3.4. Specific mechanism

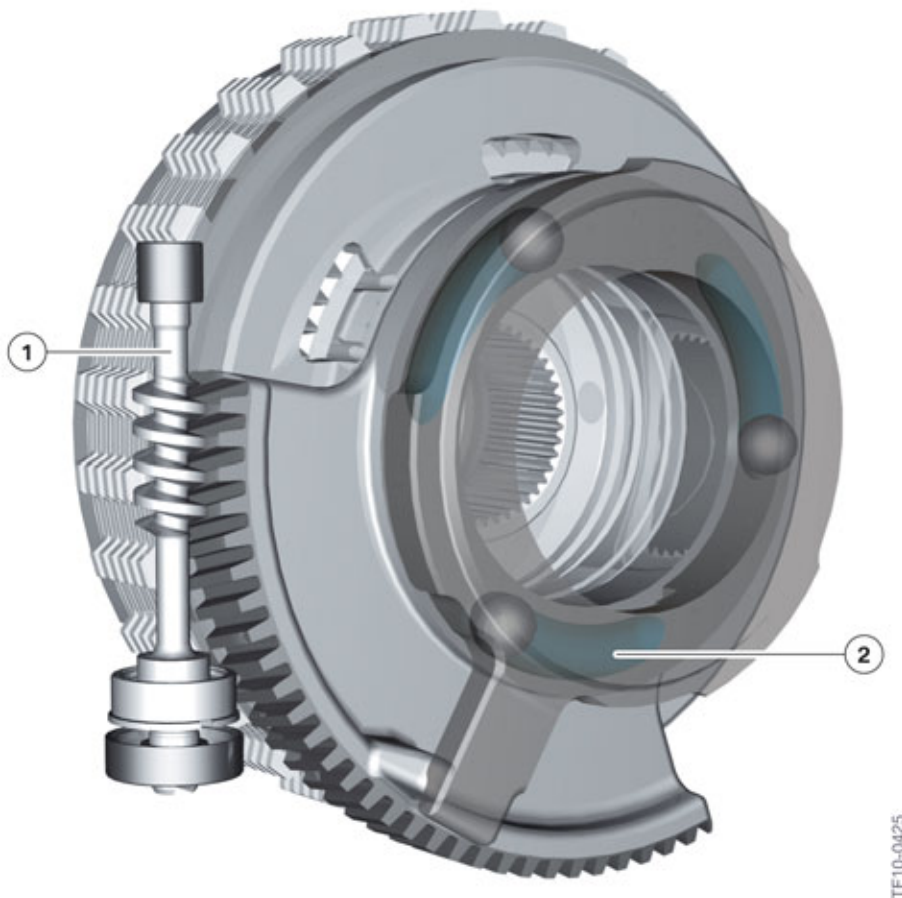

Spiral-toothed gear wheel drive with ball ramp

Index	Explanation
1	“Spiral-toothed” worm gear/wheel drive - the servomotor turns the worm gear/wheel which causes radial movement of the ball ramp
2	Ball ramp - converts the control lever's radial movement into axial piston movement in order to apply the multidisc clutch and transfer the torque to the front axle

### 4.3.5. Service information

A two-stage replacement concept exists for the ATC 450 transfer case:

- Replacement of transfer case control unit
- Replacement of transfer case including transfer case control unit.

# F25 Powertrain

## 4. Drivetrain

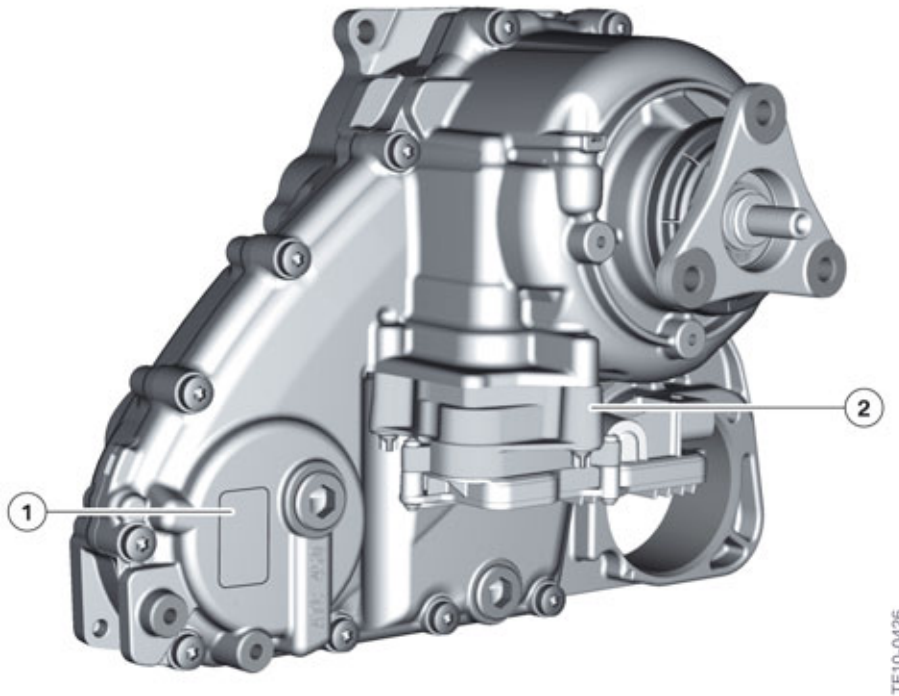

VTG ATC 450 with transfer case control unit

TF10-0425

Index	Explanation
1	Transmission serial number with classification
2	Transfer case (VTG) control unit

### 4.4. Rear axle final drive

The rear axle final drive has a spheroidal graphite cast iron housing (GGG40). Already used in the E70 and E90 but has been developed further for the F25. The HAG 188LW rear axle final drive is available in two gear ratios depending on the engine variant installed.

# F25 Powertrain

## 4. Drivetrain

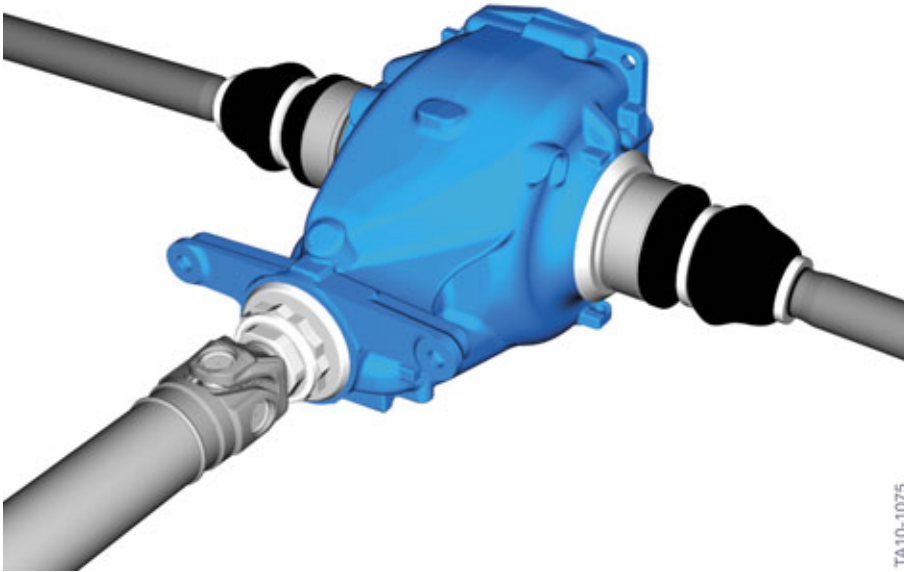

F25 Low-friction rear axle final drive

### 4.4.1. Highlights

- Weight: 28.5 kg (incl. 0.8l oil)
- Reduced transfer losses
- Optimized efficiency (approx. 1%).

Efficiency has been improved through the following:

- Use of oil with a lower viscosity
- The material of the radial shaft seals has been modified
- Optimized lubrication of pinion bearing
- The ring gear is welded to differential housing instead of bolted.

### 4.4.2. Designation

A unique designation is used for the rear axle final drive in the technical documentation in order to uniquely identify it.

Position	Meaning	Index	Explanation
1 – 3	Type of transmission	HAG	Rear axle final drive
4 – 6	Overall size	188	Diameter of ring gear pitch circle in mm
7	Bearing (internal)	L	Low-friction bearing (angular-contact ball bearing)
8	Optimization stage	W	Designed for optimum efficiency



# F25 Powertrain

## 4. Drivetrain

### 4.4.3. Variants

Model	Transmission	Rear axle final drive	Gear ratio i
X3 xDrive28i	GA8HP45Z	HAG 188LW	3.727
X3 xDrive35i	GA8HP45Z	HAG 188LW	3.385

## 4.5. Driveshafts

### 4.5.1. Overview

Both models of The F25 use a steel driveshaft.

Focal points in the design of the driveshafts were the torque transfer and comfort requirements with regard to acoustics and vibrations.

The universal joints, shaft divisions and shaft diameters have been specified in such a way that they do not transmit any disruptive noises or vibrations to the connection points at the body.

The driveshafts of the F25 are connected to the transfer case with a flexible disc and to the rear axle final drive with universal joint.

# F25 Powertrain

## 4. Drivetrain

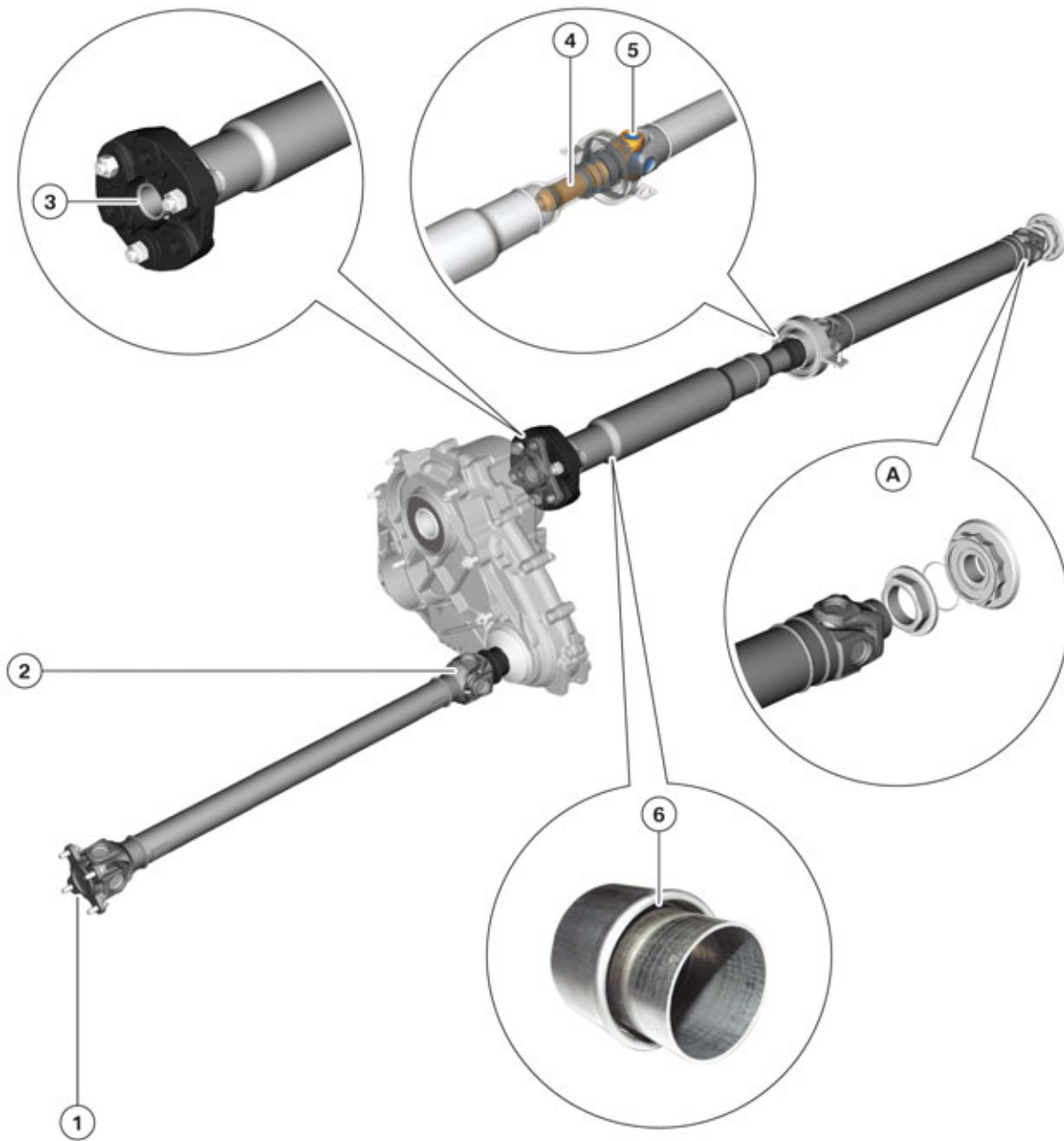

F25 driveshaft

TA10-1074

# F25 Powertrain

## 4. Drivetrain

Index	Explanation
1	Flexible disc (Flex joint)
2	Universal joint
3	Plug connection
4	Sliding joint
5	Universal joint
6	Collapsing element
A	Connection to rear axle final drive

### 4.5.2. Collapsing element

The driveshaft is equipped with a collapsing element (integrated in the front driveshaft tube) which is designed to absorb some of the deformation energy in the event of a head-on collision. This device reduces the load on the occupants and increases passive safety.

The properties of this collapsing element have been enhanced for the F25. Although the capability to transfer torque has remained unchanged, the spring force which deforms the front driveshaft tube in the event of a head-on collision has been reduced.

### 4.6. Output shafts, front axle

The front output shafts transfer the torque to the front wheels. The movement of the assemblies (engine/transmission, bearings, rear axle) along with the spring travel of the wheels and angle changes in the drivetrain must be balanced out during this process.

The front output shafts in an xDrive vehicle must take up large deflection angles caused by the steering angle at the wheel hubs. The output shafts must also be capable of transferring the maximum torque applied to them.

Up till now, output shaft journals with longitudinal splines have been used for the axle to wheel hub connection. In the F25, this connection is made by machining spur gears on both the axle and the wheel hub mating surfaces. When these components are then torqued to specifications the result is comparable to the conventional spline method. This system (first introduced in the EU with the E84 X1) simplifies the installation of the drivetrain at the assembly plant and reduces manufacturing costs.

# F25 Powertrain

## 4. Drivetrain

### 4.6.1. Overview

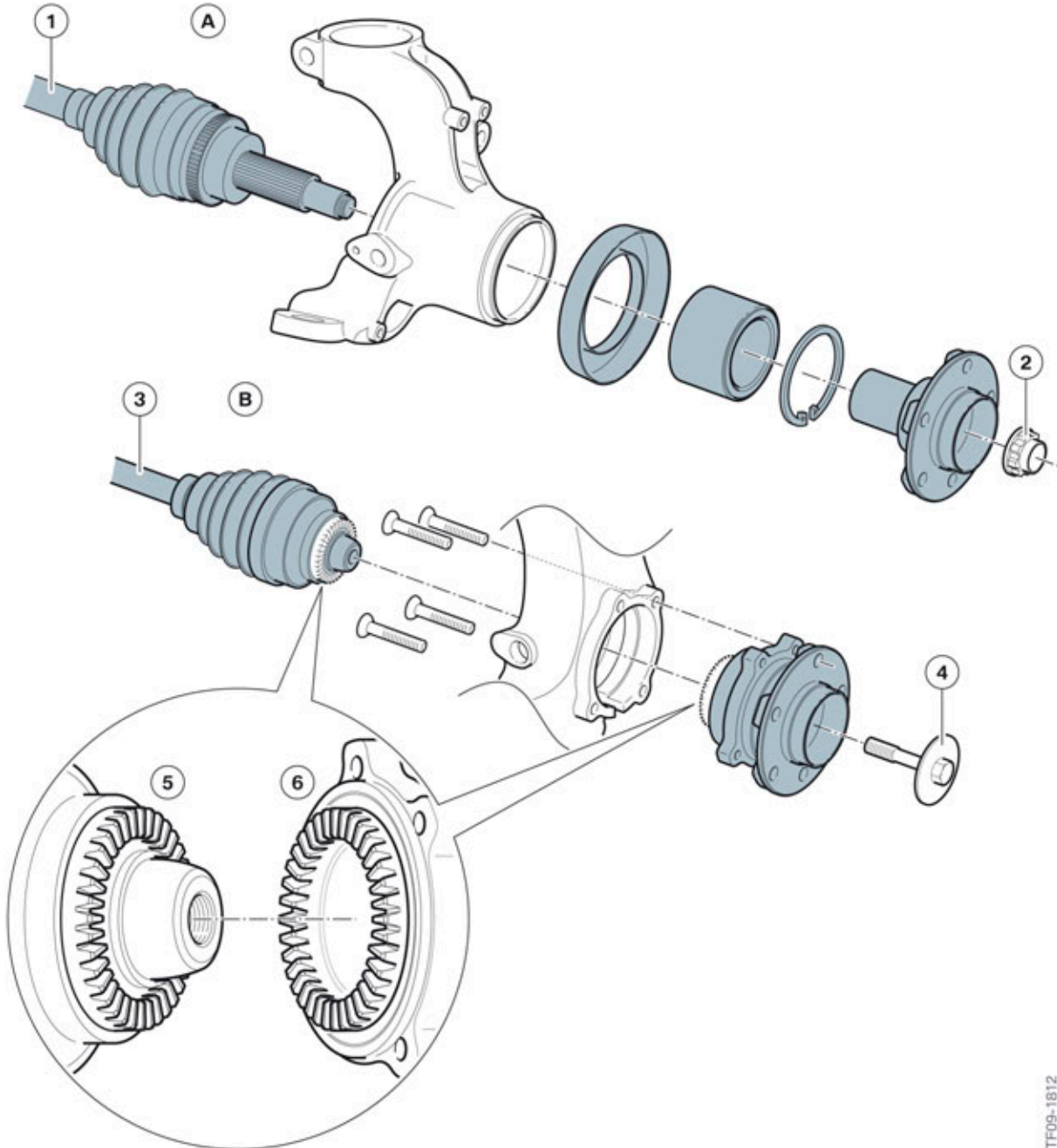

F25 Front output shaft to wheel hub connection

TF09-1812

# F25 Powertrain

## 4. Drivetrain

<b>Index</b>	<b>Explanation</b>
A	Conventional output shaft
B	Output shaft with spur gear connection
1	Front output shaft, with longitudinal splines (wheel side)
2	Castle nut
3	Front output shaft, with spur gear (wheel side)
4	Retaining screw
5	Output shaft with spur gear connection
6	Mating spur gear connection at wheel hub

# F25 Powertrain

## 4. Drivetrain



Cutaway view of the new front axle spur gear connection to the wheel hubs

# F25 Powertrain

## 4. Drivetrain

### 4.7. Output shafts, rear axle

Conventional output shafts with longitudinal splines are used at the rear axle of the F25.

The positioning of the rear axle final drive means the left and right output shafts have different overall lengths.



F25 Rear output shaft



Bayerische Motorenwerke Aktiengesellschaft  
Händlerqualifizierung und Training  
Röntgenstraße 7  
85716 Unterschleißheim, Germany