

Technical training.
Product information.
F25 Chassis Dynamics



BMW Service

Edited for the U.S. market by:
BMW Group University
Technical Training
ST1106 2/1/2011

General information

Symbols used

The following symbol is used in this document to facilitate better comprehension or to draw attention to very important information:



Contains important safety notes and information that needs to be observed strictly in order to guarantee the smooth operation of the system.

Information status and national-market versions

BMW Group vehicles meet the requirements of the highest safety and quality standards. Changes in requirements for environmental protection, customer benefits and design render necessary continuous development of systems and components. Consequently, there may be discrepancies between the contents of this document and the vehicles available in the training course.

This document basically relates to left-hand drive vehicles with European specifications. Some controls or components are arranged differently in right-hand drive vehicles than shown in the graphics in this document. Further differences may arise as the result of the equipment variations used in specific markets or countries.

Additional sources of information

Further information on the individual topics can be found in the following:

- Owner's Handbook
- Integrated Service Technical Application.

©2010 BMW AG, Munich

Reprints of this publication or its parts require the written approval of BMW AG, München

The information contained in this document form an integral part of the technical training of the BMW Group and is intended for the trainer and participants in the seminar. Refer to the latest relevant information systems of the BMW Group for any changes/additions to the Technical Data.

Status of the information: **July 2010**
VH-23/International Technical Training

F25 Chassis Dynamics

Contents

1.	Introduction	1
1.1.	Driving dynamics and comfort.....	1
1.2.	Bus overview.....	2
2.	Models	5
2.1.	Comparison.....	5
3.	Chassis and suspension	6
3.1.	Front axle.....	6
3.1.1.	Technical Data F25.....	7
3.1.2.	Service Information.....	8
3.2.	Rear axle.....	9
3.2.1.	Technical data.....	11
3.2.2.	Notes for Service.....	11
3.3.	Wheels and tires.....	12
3.4.	Tire Pressure Monitoring.....	13
3.4.1.	Operating principle.....	13
3.4.2.	System overview of TPM.....	15
3.4.3.	System wiring diagram.....	16
3.4.4.	Notes for Service.....	17
3.5.	Suspension/dampers.....	19
4.	Brakes	20
4.1.	Service brakes.....	20
4.2.	EMF Electromechanical Parking Brake.....	21
4.2.1.	System overview.....	22
4.2.2.	System wiring diagram.....	24
4.2.3.	System structure.....	25
4.2.4.	System function.....	26
4.2.5.	Check Control messages.....	34
5.	Steering	40
5.1.	Electronic Power Steering EPS.....	40
5.1.1.	System overview.....	42
5.1.2.	System wiring diagram.....	43
5.1.3.	Steering angle sensor.....	44
5.2.	Variable sport steering.....	44
5.2.1.	System overview.....	45
5.3.	Steering column.....	46
5.3.1.	Steering column adjustment.....	46

F25 Chassis Dynamics

Contents

6.	Driving stability control systems	47
6.1.	Directions of action.....	47
6.2.	Integrated Chassis Management (ICM).....	47
6.2.1.	System overview.....	47
6.2.2.	System function.....	48
6.3.	Dynamic Stability Control DSC.....	49
6.3.1.	System overview.....	50
6.3.2.	System wiring diagram.....	51
6.4.	xDrive.....	55
6.4.1.	System overview.....	55
6.4.2.	VTG control unit system wiring diagram.....	57
6.4.3.	Drive function.....	58
6.5.	Performance Control.....	60
6.6.	Dynamic Cruise Control DCC.....	60
6.7.	Electronic Damper Control (EDC).....	62
6.7.1.	System overview.....	62
6.7.2.	System wiring diagram.....	63
6.7.3.	System function.....	64
6.7.4.	Service information.....	65
6.8.	Driving dynamics control switch.....	65

F25 Chassis Dynamics

1. Introduction

1.1. Driving dynamics and comfort

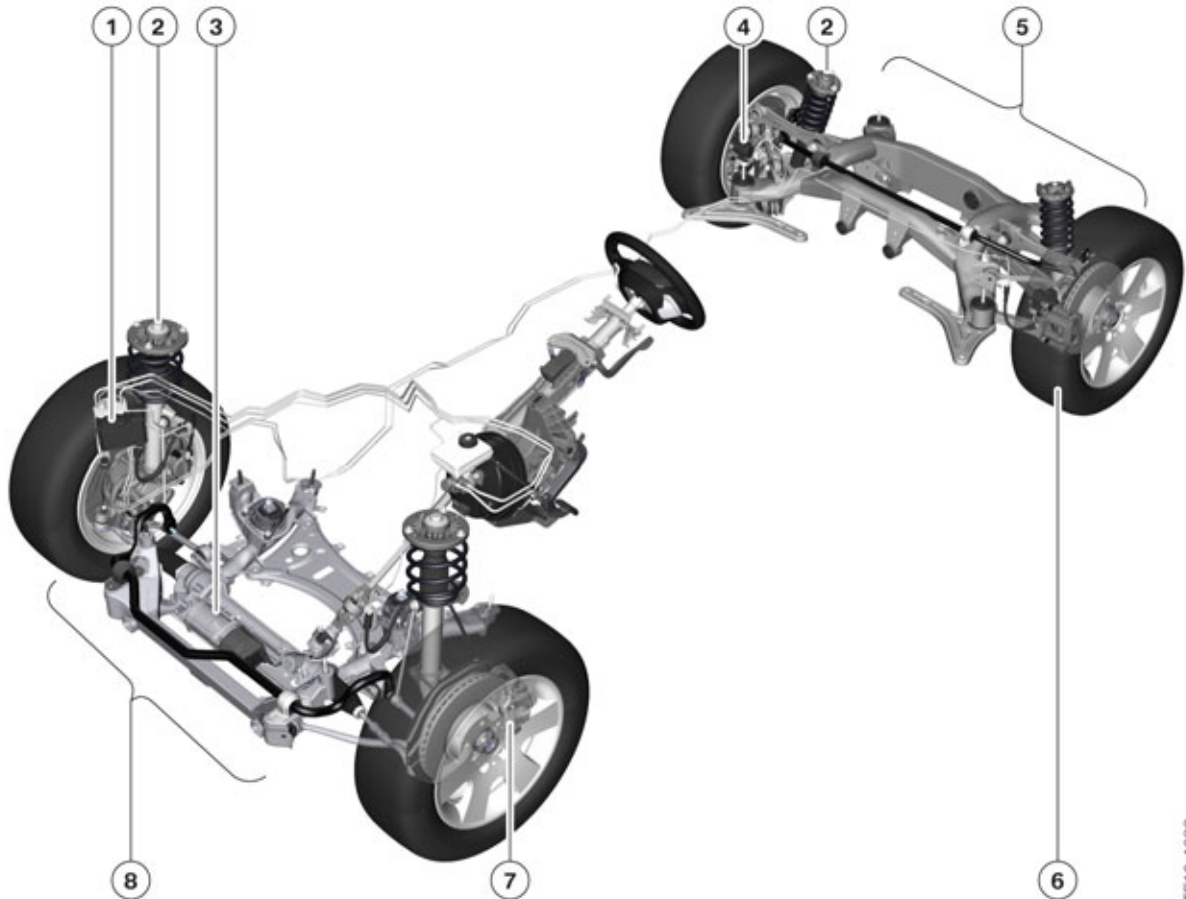

F25 Chassis and suspension

TF10-1083

Index	Explanation
1	Dynamic Stability Control (DSC)
2	Suspension/dampers
3	Electronic Power Steering (EPS)
4	EMF Electromechanical Parking Brake
5	Five-link rear axle
6	Wheels
7	Brakes
8	Two-joint spring strut front axle with trailing links

The chassis and suspension of the F25 is a further development of the E83 at the front axle. A version of the established HA5 five-link rear axle used in the E84 has been improved and adapted to the F25 and is used at the rear axle. The chassis and suspension sets new standards when it comes to driving dynamics and comfort.

F25 Chassis Dynamics

1. Introduction

1.2. Bus overview

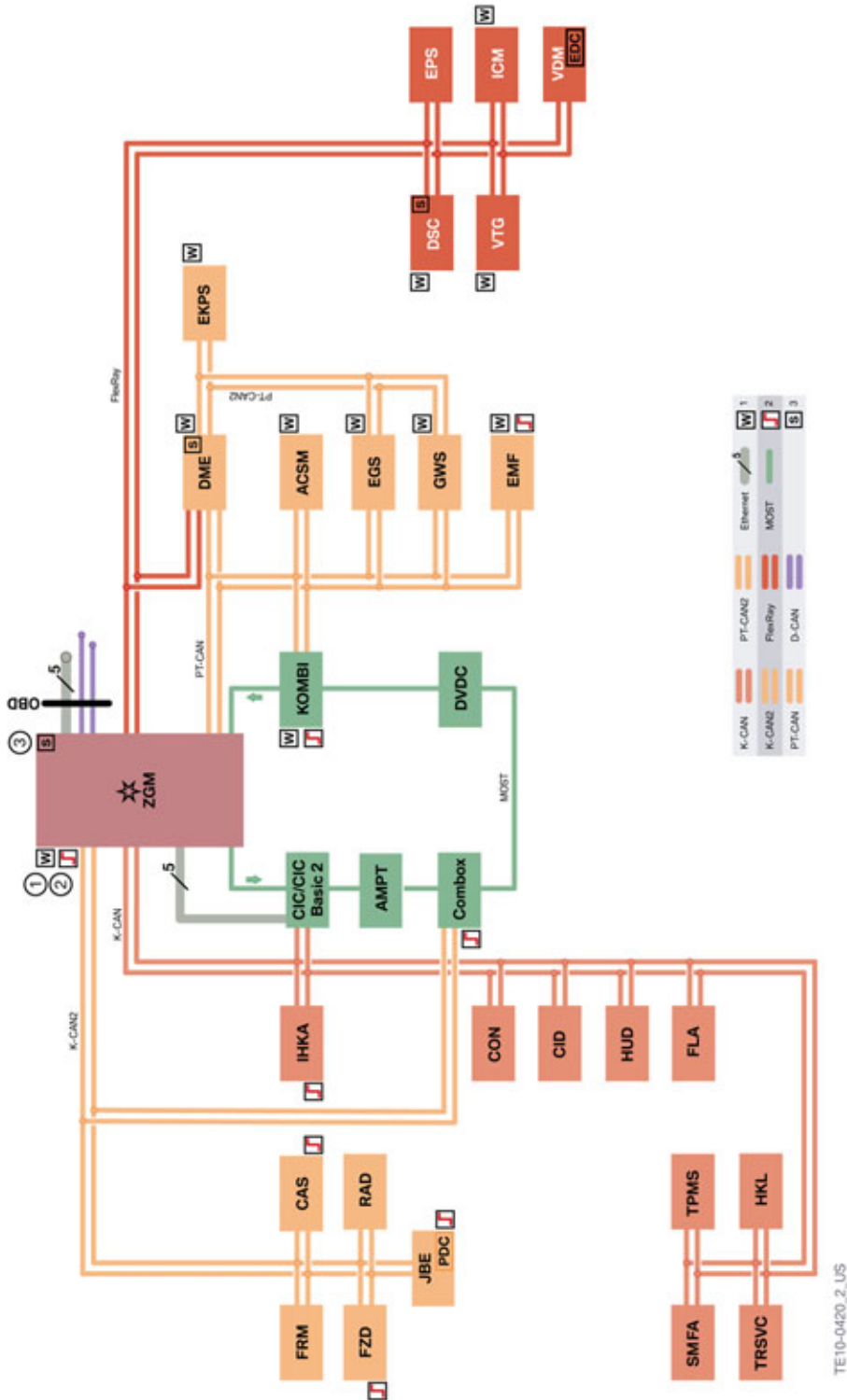

F25 Bus overview

F25 Chassis Dynamics

1. Introduction

Index	Explanation
1	Wakeable control units
2	Control units with wake-up authorization
3	Start-up-device control units for starting up and synchronizing the FlexRay bus system
ACSM	Advanced Crash Safety Module
AMPT	Top HiFi amplifier
CAS	Car Access System
CID	Central Information Display
COMBOX	Combox (Combox multimedia, Combox multimedia with telematics)
CON	Controller
D-CAN	Diagnosis-on CAN
DME	Digital Engine Electronics
DSC	Dynamic Stability Control
DVDC	DVD changer
EDC	Electronic Damper Control (EDC)
EGS	Electronic transmission control unit
EKPS	Electric fuel pump
EMF	Electromechanical parking brake
EPS	Electronic power steering (electromechanical power steering)
Ethernet	Wired data network system for local data networks
FLA	High-beam assistant
FlexRay	Fast, pre-configured and error-tolerant bus system for automotive use
FRM	Footwell module
FZD	Roof function center
GWS	Gear selector switch
HEADUNIT	Headunit (Car Information Computer or Car Information Computer Basic II)
HKL	Automatic luggage compartment lid actuation
HUD	Head-Up display
ICM	Integrated Chassis Management
IHKA	Automatic integrated heating and A/C control unit
JBE	Junction Box Electronics
K-CAN	Body controller area network
K-CAN2	Body controller area network 2
KOMBI	Instrument panel
MOST	Media Oriented System Transport

F25 Chassis Dynamics

1. Introduction

Index	Explanation
OBD	On-board diagnosis (diagnostic socket)
PDC	Park Distance Control
PT CAN	Drive train Controller Area Network
PT CAN2	Drive train Controller Area Network 2
RAD	Radio
SMFA	Driver's seat module
TPMS	Tire Pressure Monitoring System
TRSVC	Control unit for camera systems
VDM	Vertical Dynamics Management
VTG	Transfer box
ZGM	Central gateway module

F25 Chassis Dynamics

2. Models

2.1. Comparison

A comparison is made in the following table between the Technical Data of the chassis and suspension of the F25 and its predecessor, the E83.

Designation	F25 xDrive28i	E83 xDrive30si
Wheelbase	2810 mm/110.6 in	2795 mm/110 in
Track width, front	1616 mm/63.6 in	1613 mm/63.5 in
Rear track width	1632 mm/64.3 in	1602 mm/63 in
Tires, basic wheels	245/55 R17	235/55 R17
Wheel rims, basic wheel	17 x 8.0	17 x 7.0
Front axle	Two-joint spring strut front axle with trailing links	Two-joint spring strut front axle with trailing links
Suspension/damping, front	Steel spring/conventional or EDC	Steel springs, conventional
Anti-roll bar, front	mechanical	mechanical
Front brake	Brake disc dia. 328 mm/12.9 in	Brake disc dia. 325 mm/12.7 in
Steering	EPS rack	Rack
Rear axle	Five-link rear axle (HA5 five-link)	Central link rear suspension
Rear suspension/dampers	Steel spring/conventional or EDC	Steel springs, conventional
Rear anti-roll bar	mechanical	mechanical
Rear brakes	Brake disc dia. 330 mm/13 in	Brake disc dia. 320 mm/12.5 in
Parking brake	Disc brake with electromechanical parking brake	Duo-servo parking brake with parking brake lever

F25 Chassis Dynamics

3. Chassis and suspension

3.1. Front axle

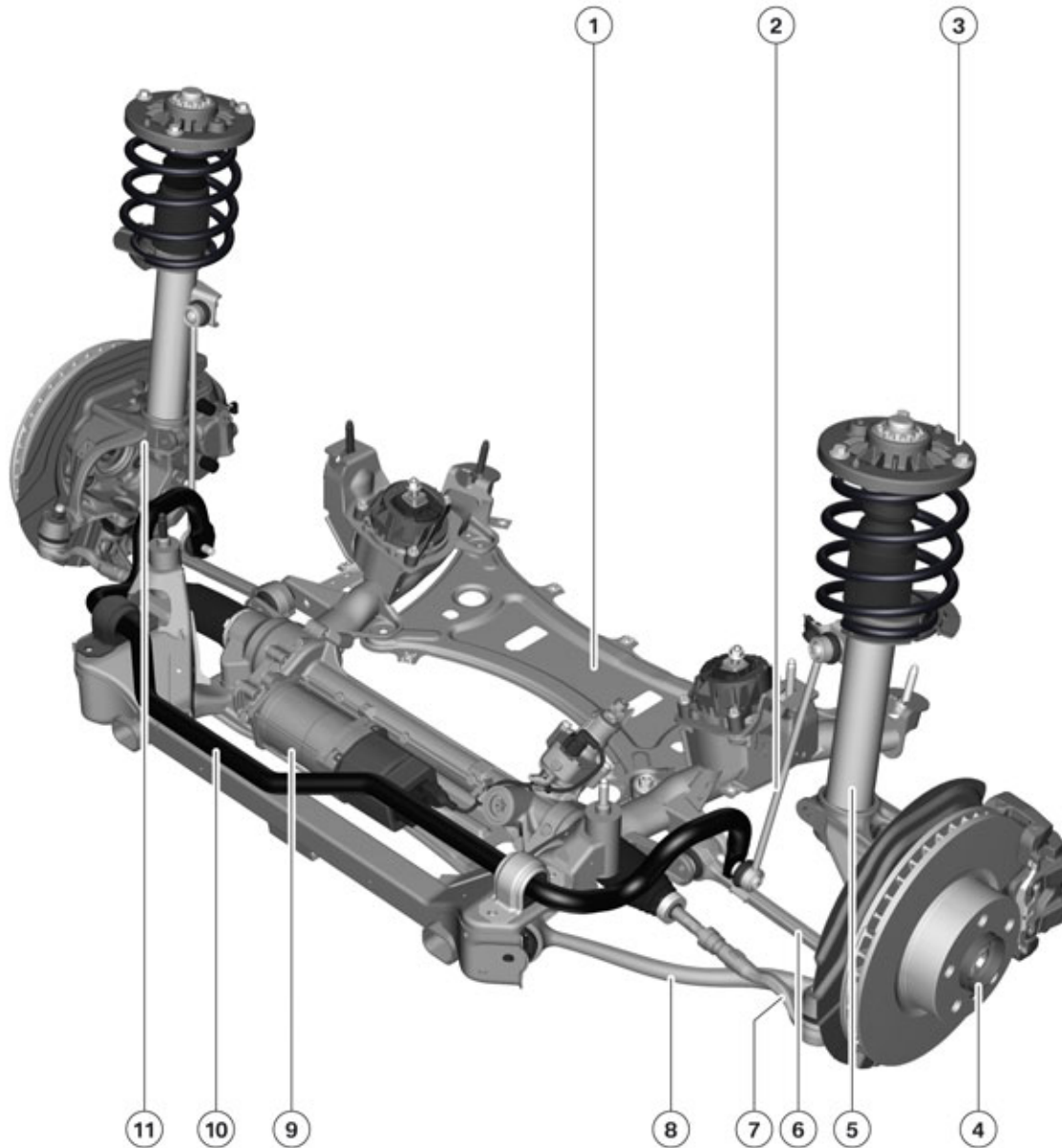

TF10-1057

F25 Two-joint spring strut front axle with trailing links

Index	Explanation
1	Front axle support
2	Anti-roll bar link
3	Support bearing
4	Wheel hub
5	Spring strut
6	Wishbone

F25 Chassis Dynamics

3. Chassis and suspension

Index	Explanation
7	Track rod
8	Trailing link
9	Steering box, EPS
10	Anti-roll bar
11	Swivel bearing

The two-joint spring strut front axle with trailing links in the F25 offers the ideal combination of driving dynamics and ride comfort. The supporting function of the steering box housing achieves extremely high rigidity with minimum weight.

Low-friction ball joints are used in the front axle. This has greatly improved the response characteristics.

The standard Electronic Power Steering EPS (electromechanical power steering) is a new feature of the F25 and makes a significant contribution to "EfficientDynamics". (2VL Variable sport steering is available as an option)

The Electronic Damper Control EDC is available as optional equipment (SA 223 Dynamic Damper Control) to be used in conjunction with conventional dampers.

The front axles installed in the off-road vehicles are listed in the table below.

Vehicle type	Version for front axle
F25	Two-joint spring strut front axle with trailing links
E53	Two-joint spring strut front axle with trailing links
E70	Double wishbone suspension
E83	Two-joint spring strut front axle with trailing links
E84	Two-joint spring strut front axle with: <ul style="list-style-type: none">• Trailing links for sDrive• Leading links with xDrive

3.1.1. Technical Data F25

Designation	
Caster angle	5° 48'
Camber	-0° 30'
Total toe-in	6'
Toe difference angle	1.5°
Steering axis inclination	11° 48'
Kingpin offset	8.2 mm with 17" wheel

F25 Chassis Dynamics

3. Chassis and suspension

Designation	
Track width	1616 mm with 17" wheel
Maximum wheel lock angle, outer	32° 6'
Maximum wheel lock angle, inner	38°

Note: The camber can be corrected by using approved swivel bearings which are available from the parts department.

Two versions of the swivel bearings are available:

- Version 1: camber correction -0° 30'
- Version 2: camber correction 0° 30'.

3.1.2. Service Information

The following tables show when front axle wheel alignment is necessary.

Component replaced	Wheel alignment required
Front axle support	YES
Steering box (without track rods)	YES
Wishbone	YES
Rubber mount for wishbone	YES
Trailing link	NO
Rubber mount for trailing link	NO
Wheel control joint	NO
Track rod	YES
Swivel bearing	YES
Spring strut	NO
Support bearing	NO

Screw connection unfastened	Wheel alignment required
Front axle support to body (lowering)	NO
Steering box to front axle support	YES
Wishbone on front axle support	YES
Wishbone on swivel bearing	NO
Trailing link to front axle support	NO
Trailing link on wheel control joint	NO
Wheel control joint on swivel bearing	NO
Track rod to steering box	NO
Track rod end to track rod	YES

F25 Chassis Dynamics

3. Chassis and suspension

Screw connection unfastened	Wheel alignment required
Track rod end to swivel bearing	NO
Spring strut on swivel bearing	NO
Support bearing to body	NO
Steering shaft on steering box	NO
Steering column on steering shaft	NO

3.2. Rear axle

The HA5 five-link rear axle installed in the F25 is derived from a double wishbone rear axle with rear-mounted track rod. Although the engineering design principle of the rear axle is based on the one used in the E8x and E9x vehicles, this version is characterized by its low installation space requirement and light weight of its components.

In addition to a particularly precise wheel control, this design delivers outstanding driving dynamics in relation to the following:

- Directional stability, accuracy
- Load change response
- Self-steering response
- Lane change stability
- Steering movement (transitional response from cornering to straight-ahead driving).

The two conflicting objectives, driving dynamics and comfort have been successfully adapted with the use of:

- double-elastic rubber mounting bearing
- rear axle suspension with reduced preload (via high suspension ratio)
- wide supporting base of rear axle support
- high structural rigidity of rear axle support

The optimized elasto-kinematics ensures ride comfort as the use of small but effective control arms means that the rear axle hardly reacts to interference.

In contrast to the E84 and E9x series, spring struts are installed at the rear axle instead of the split arrangement of springs/dampers. A high suspension ratio has been achieved through the installation of spring struts.

The flat space-saving design of the axle with wide spring struts mounted on the outside results in a flat luggage compartment floor with generous loading width.

Low unsprung masses have been implemented using innovative sheet-metal control arm technology.

The rear axles installed in the off-road vehicles are listed in the table below.

F25 Chassis Dynamics

3. Chassis and suspension

Vehicle type	Version, rear axle
F25	Five-link rear axle
E53	Integral IV rear axle
E70	Integral IV rear axle
E83	Central link rear suspension
E84	Five-link rear axle

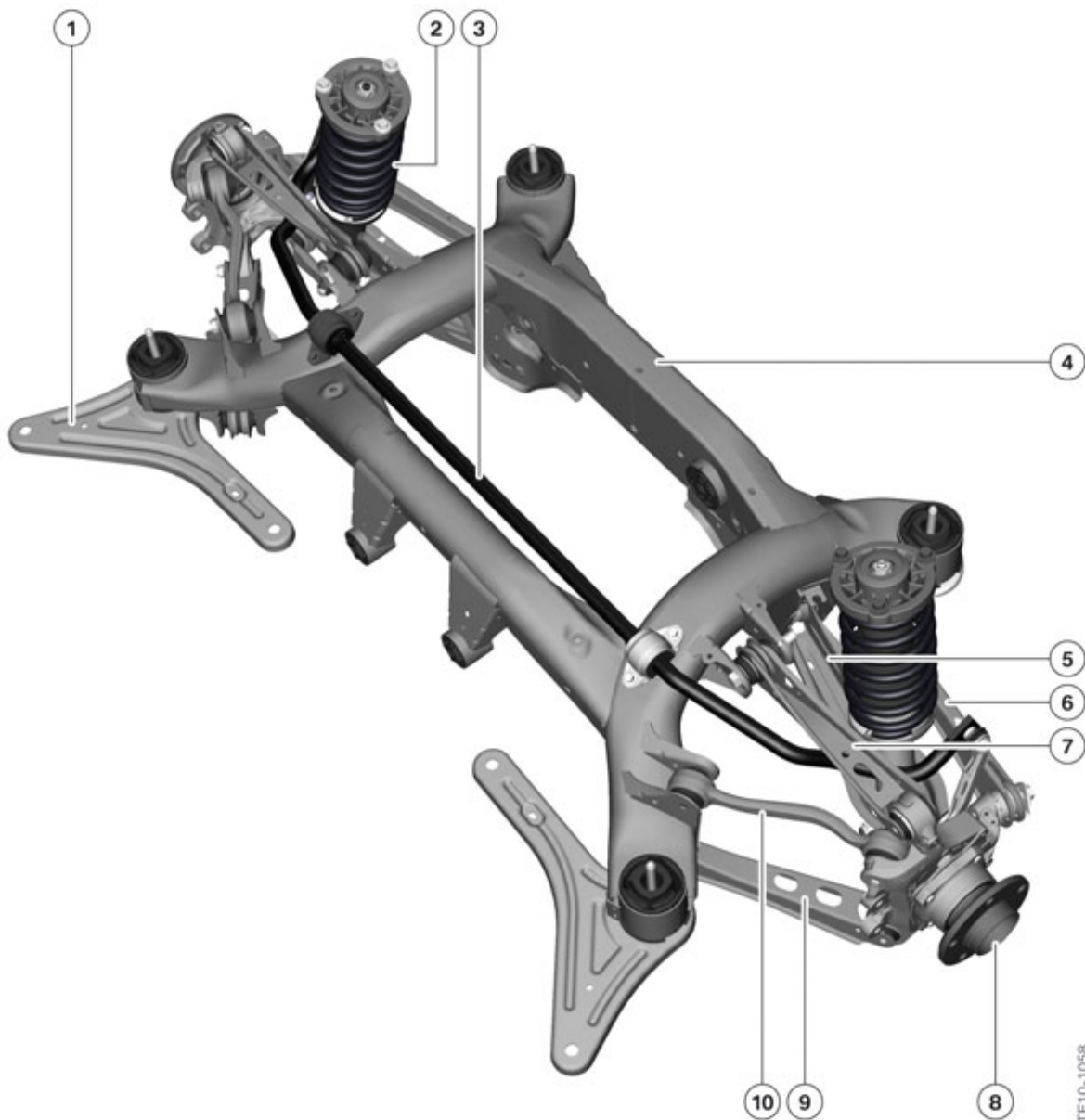

TF10-1058

F25 Five-link rear axle

F25 Chassis Dynamics

3. Chassis and suspension

Index	Explanation
1	Compression strut
2	Spring strut
3	Anti-roll bar
4	Rear axle support
5	Wishbone, bottom
6	Toe arm
7	Wishbone, top
8	Wheel bearing
9	Camber link
10	Control arm

3.2.1. Technical data

Designation	
Total toe-in	12'
Camber	-1° 30'
Track width	1632 mm

3.2.2. Notes for Service

The following tables show when rear axle wheel alignment is necessary.

Component replaced	Wheel alignment required
Rear axle support	YES
Rubber mount for rear axle support	NO
Control arm	NO
Rubber mount for control arm	NO
Toe arm	YES
Rubber mount for control arm	YES
Camber link	YES
Rubber mount for camber link	YES
Trailing arm	NO
Rubber mount for trailing arm	NO
Wishbone	YES
Rubber mount/joint for wishbone	YES
Wheel carrier	YES

F25 Chassis Dynamics

3. Chassis and suspension

Component replaced	Wheel alignment required
Rubber mount/joint for wheel carrier	YES
Spring strut	NO
Rubber mount in spring strut	NO
Support bearing	NO

Screw connection unfastened	Wheel alignment required
Rear axle support to body	NO
Compression strut to body	NO
Control arm to rear axle support	NO
Control arm to wheel carrier	NO
Camber link to rear axle support	YES
Camber link to wheel carrier	NO
Camber link to rear axle support	YES
Camber link to wheel carrier	NO
Trailing arm to rear axle support	NO
Trailing arm to wheel carrier	NO
Wishbone to rear axle support	NO
Wishbone to wheel carrier	NO
Spring strut to camber link	NO
Support bearing to body	NO

3.3. Wheels and tires

The tables below list the sizes of the standard tires and wheels.

	xDrive28i	xDrive35i
tires, front	245/55 R17	245/50 R18
Rear tires	245/55 R17	245/50 R18
Wheel rim, front	17 x 8 light alloy	18 x 8 light alloy
Rear wheel rim	17 x 8 light alloy	18 x 8 light alloy
Rim offset IS front	32 mm	43 mm
Rim offset IS rear	32 mm	43 mm

F25 Chassis Dynamics

3. Chassis and suspension

3.4. Tire Pressure Monitoring

3.4.1. Operating principle

The F25 is being equipped with the latest generation of tire pressure monitoring systems.

The direct measuring system consists of the TPM control unit with integrated reception antenna and four wheel electronics. It was possible to reduce the number of components and cost of the system by integrating the reception antenna in the TPM control unit.

The four wheel electronics transmit the tire pressure and temperature to the TPM control unit via radio communication (433 MHz). Once the wheel electronics have been woken up, (vehicle speed > 20 km/h/12mph), a total of 25 telegrams are transmitted once at two second intervals. Providing the pressure has not dropped, individual telegrams are then sent every 18 seconds from the wheel electronics to the TPM control unit. As a prerequisite for the wheel electronics to go to sleep, the wheel must be at a standstill for more than five minutes.

Resetting the tire pressure values

The tire pressure values are reset via the instrument panel or Central Information Display CID. The TPM text message appears, or the permanent TPM indicator light lights up, in the instrument panel when the teach-in process starts.

Teach-in process

During the teach-in process, the wheel electronics identification numbers (ID) are transmitted to the TPM control unit. The TPM control unit can identify the wheel position of the corresponding wheel electronics via the identification numbers once the teach-in process is complete.

Two acceleration sensors are installed in each of the wheel electronics in order to be able to determine their positions. The acceleration sensors determine the wheel's direction of rotation. This means that right/left differentiation of the wheel electronics positions at the vehicle is possible.

The high frequency signals received are evaluated in order to determine whether the wheel electronics are at the front or rear axle. The TPM control unit with integrated receiver is mounted in the outer area of the luggage compartment well above the rear axle. The level of the signals received by the TPM control unit from the wheels on the rear axle is higher than the level of signals sent by the wheel electronics on the front axle. This means it is possible to determine whether the wheel electronics are at the front or rear of the vehicle.

The entire teach-in process takes between roughly one and twelve minutes at the most. The following factors influence the duration:

- The condition of the road (e.g. cobbles)
- The current mode of the wheel electronics (awake/gone to sleep)
- The TPM control unit already knows what the IDs of the wheel electronics are.

F25 Chassis Dynamics

3. Chassis and suspension

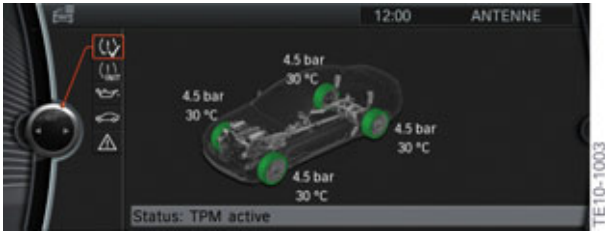

F25 TPM, teach-in process complete

Once the teach-in process is complete, the TPM text message or solid TPM indicator light are cancelled. The green tire symbols subsequently appear in the CID.

Pressure drop

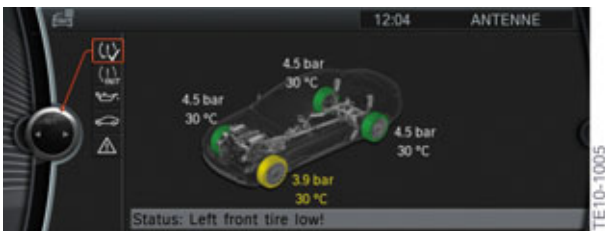

F25 TPM pressure drop

Once the teach-in process is complete, the wheel electronics send the pressure, temperature and also the identification numbers of the tires to the TPM control unit at regular intervals when driving.

If a pressure change of > 20 kPa (0.2 bar, 2.9 psi) is identified within two successive pressure measurements, the wheel electronics for the relevant wheel immediately assumes a fast transmitting mode. It then sends information to the control unit at one-second intervals. If the pressure drop is higher than 25%, the TPM text message "Tire Low" appears.

F25 Chassis Dynamics

3. Chassis and suspension

3.4.2. System overview of TPM



F25 System overview of TPMS

TF10-1059

Index	Explanation
1	Wheel electronics (battery-operated sensor with transmitter unit 433MHz)
2	Instrument panel (KOMBI)
3	Control unit with integrated reception antenna

F25 Chassis Dynamics

3. Chassis and suspension

3.4.3. System wiring diagram

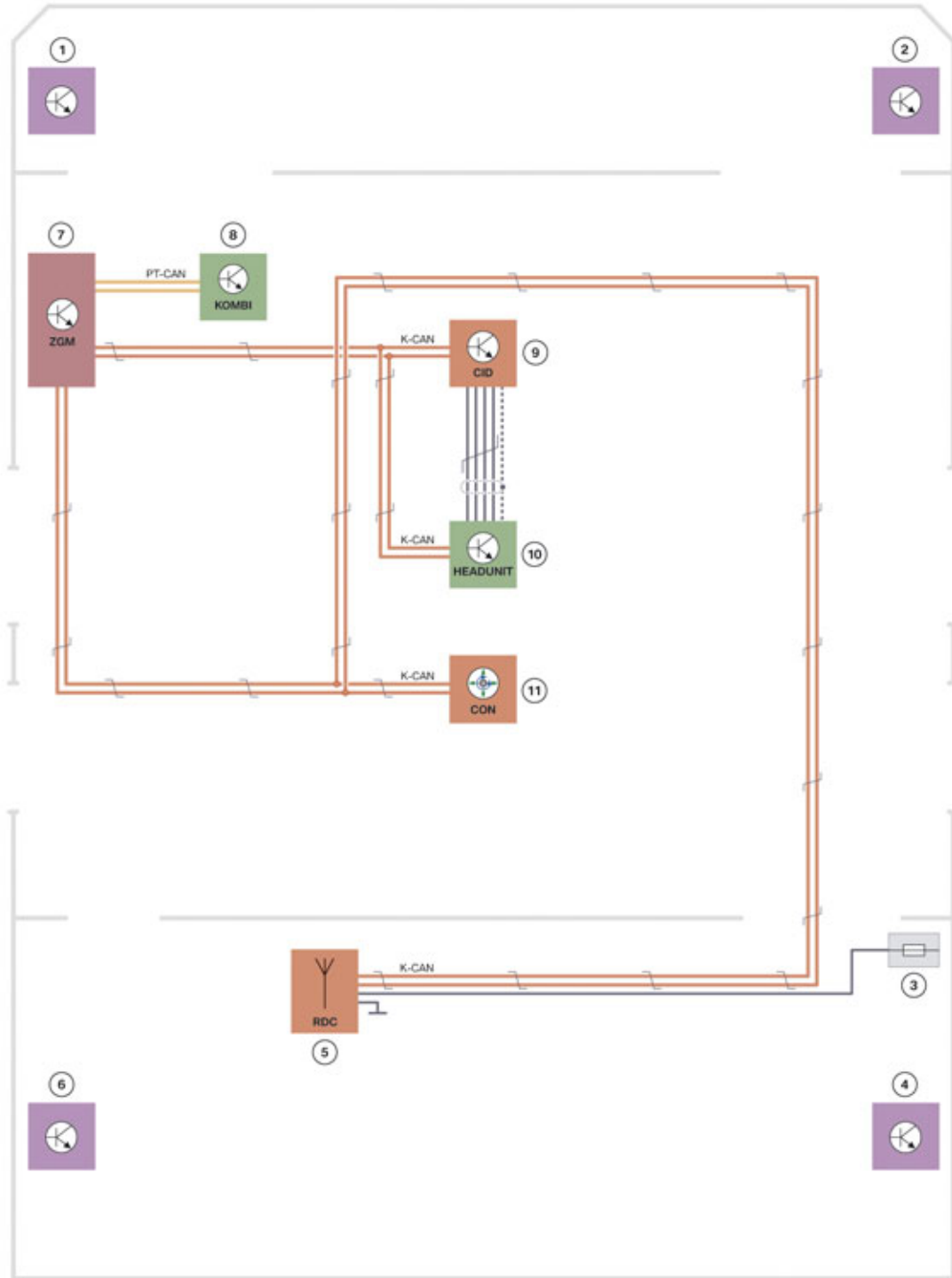

TF10-0808

F25 System wiring diagram, TPMS

F25 Chassis Dynamics

3. Chassis and suspension

Index	Explanation
1	Wheel electronics, front left
2	Wheel electronics, front right
3	Power distribution box, luggage compartment
4	Wheel electronics, rear right
5	Tire pressure monitoring control (TPM)
6	Wheel electronics, rear left
7	Central gateway module ZGM
8	Instrument panel (KOMBI)
9	Central Information Display (CID)
10	Headunit
11	Central operating element
KI.30B	Terminal 30, time-dependent

3.4.4. Notes for Service

Teach-in process

The wheel electronics must be taught in under the following circumstances:

- The tire pressure has been changed
- A tire has been changed
- Wheels are replaced axle-wise.

The driver can start the teach-in process via the Central Information Display CID and the controller. For more information, refer to the vehicle Owner's manual.

Service life of batteries for wheel electronics

The service life of the batteries installed in the wheel electronics is roughly 7.5 years. The current value of the service life counter in the batteries of the wheel electronics can be read out via the diagnosis system.

If the battery is fully discharged or defective, an TPM fault message is displayed.

Remove/install wheel electronics

The following points must be observed when removing/installing the wheel electronics of the tire pressure control (TPM):

F25 Chassis Dynamics

3. Chassis and suspension

- Do not use high pressure cleaners to clean wheel rim with the wheel electronics installed when the tire has been removed
- Replace the wheel electronics if tire sealant has been used
- Clean the valve and valve seat thoroughly before installing the wheel electronics
- Do not apply solvents or cleaning agents to the wheel electronics, or clean them with compressed air
- To clean the wheel electronics, simply wipe down with a clean cloth.

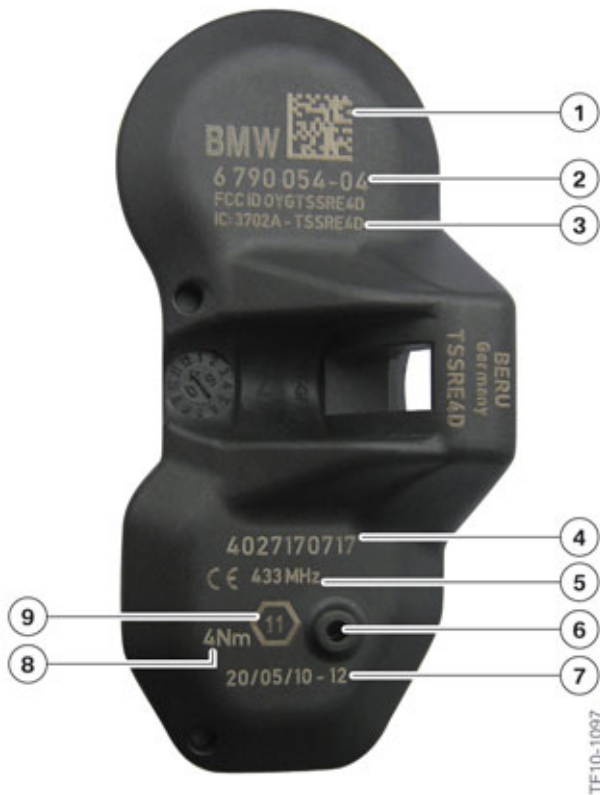

F25 Wheel electronics, TPM

Index	Explanation
1	Data Matrix Code
2	BMW part number
3	FCC ID = approval for wireless operation
4	Wheel electronics ID
5	Transmission frequency (433MHz)
6	Pressure sensor
7	Production date of wheel electronics
8	Tightening torque
9	Width across flats of union nut

F25 Chassis Dynamics

3. Chassis and suspension

3.5. Suspension/dampers

The F25 is fitted with steel springs on the front and rear axle. The damping action is provided by conventional shock absorbers as standard.

The Electronic Damper Control EDC (SA 223) is available as optional equipment. The EDC is a sub-function of the Vertical Dynamics Management VDM. The damper characteristics stored in the VDM control unit can be selected via the driving dynamics control switch in the center console.

For additional information on the EDC, refer to Chapter 6.7 - EDC.

F25 Chassis Dynamics

4. Brakes

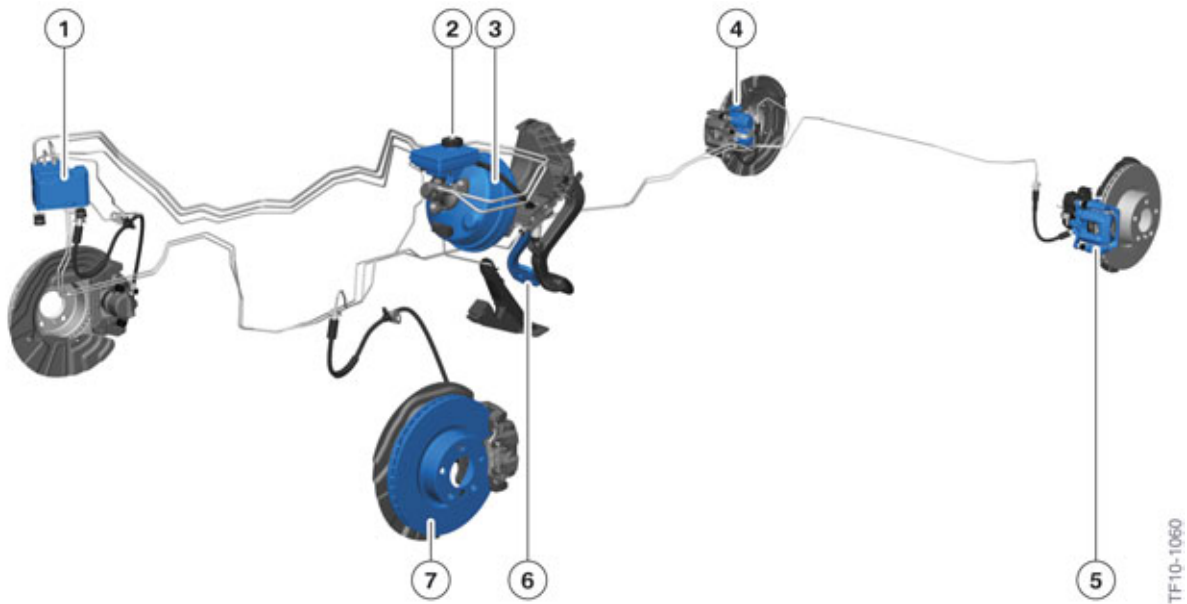

TF10-1060

F25 Service brake

Index	Explanation
1	Dynamic Stability Control, DSC
2	Brake fluid expansion tank
3	Brake servo
4	Electromechanical parking brake actuator
5	Brake caliper
6	Brake pedal
7	Brake disc

4.1. Service brakes

The F25 has a hydraulic dual-circuit brake system with front/rear split. Conventional internally ventilated brake discs are installed at the front and rear axle of all F25 engine versions. Grey cast iron floating caliper brakes are installed at the front and rear axle. In this instance, the EMF actuator on the rear axle is integrated in the brake caliper.

The familiar brake pad wear monitoring function for the Condition Based Service display continues to be used. Brake pad wear sensors are therefore installed at the front left and rear right wheel brakes.

The brake dimensions of the F25 are listed in the following table.

Front axle	xDrive28i/35i
Brake disc diameter mm/in	328 mm/12.9 in
Brake disk thickness mm/in	28 mm/1.10 in
Brake piston diameter mm/in	57 mm/2.24 in

F25 Chassis Dynamics

4. Brakes

Rear axle	xDrive28i/35i
Brake disc diameter mm/in	330 mm/13 in
Brake disk thickness mm/in	20 mm/0.78 in
Brake piston diameter mm/in	42 mm/1.65 in

4.2. EMF Electromechanical Parking Brake

On the F25 there is an EMF integrated in the rear brake calipers.

The use of the electromechanical parking brake offers the following advantages:

- Operation via an ergonomically designed button in the center console
- Safe and reliable application and release of the parking brake under all pre-conditions
- Automatic Hold function (ACC Active Cruise Control)
- Dynamic emergency braking function ensured by way of the control systems (ABS), even with a low coefficient of friction
- Discontinuation of the parking brake lever in the center console makes room for new equipment features.

F25 Chassis Dynamics

4. Brakes

4.2.1. System overview

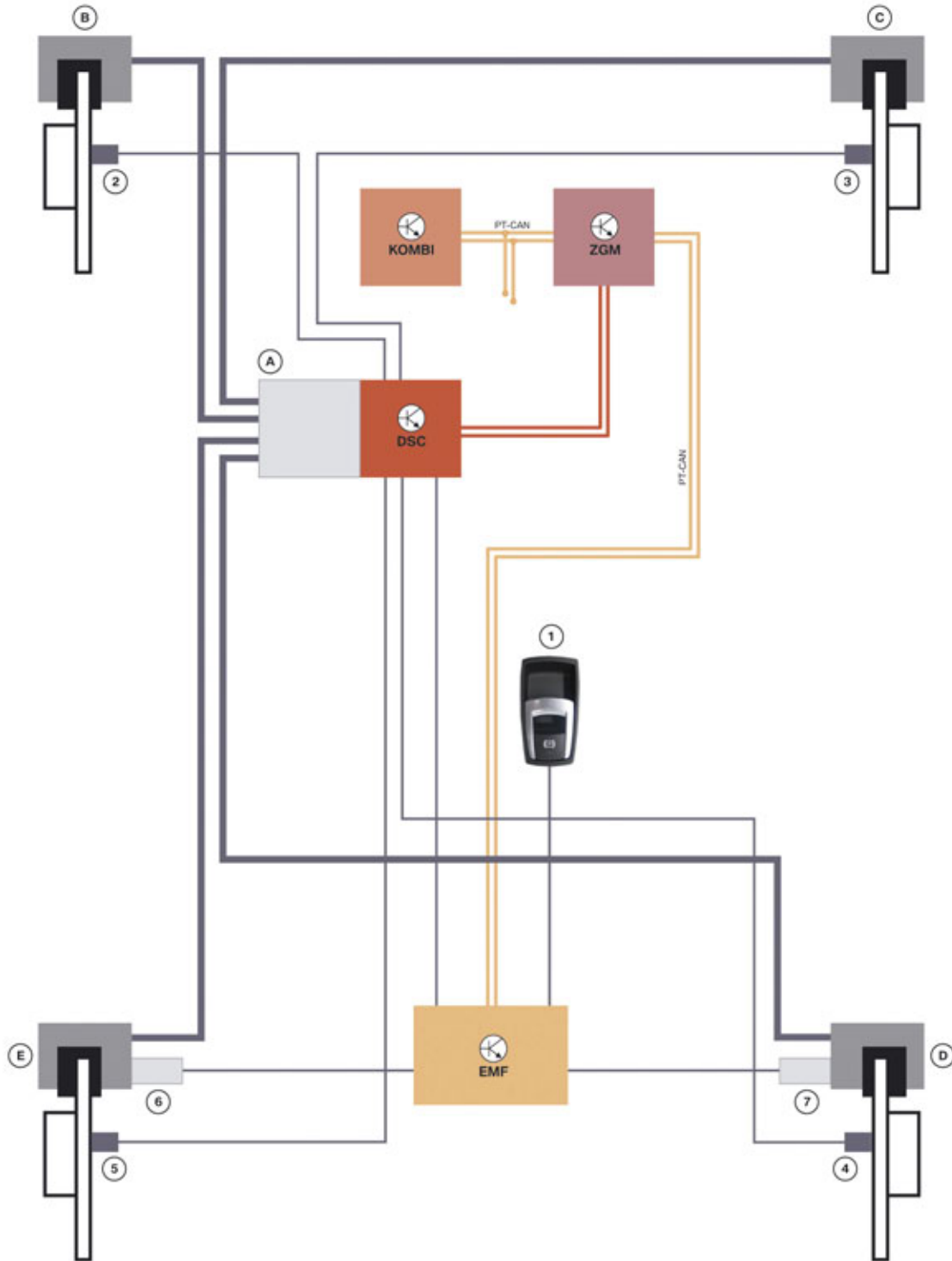

F25 System overview, EMF

TF09-1959

F25 Chassis Dynamics

4. Brakes

Index	Explanation
A	DSC unit
B	Brake caliper, front left
C	Brake caliper, front right
D	Brake caliper, rear right
E	Brake caliper, rear left
1	Parking brake button
2	Wheel speed sensor, front left (not used for the EMF)
3	Wheel speed sensor, front right (not used for the EMF)
4	Wheel speed sensor, rear right
5	Wheel speed sensor, rear left
6	EMF actuator, rear left
7	EMF actuator, rear right
KOMBI	Instrument panel (KOMBI)
ZGM	Central gateway module
DSC	Dynamic Stability Control
PT CAN	Drive train Controller Area Network
EMF	Electromechanical parking brake

F25 Chassis Dynamics

4. Brakes

4.2.2. System wiring diagram

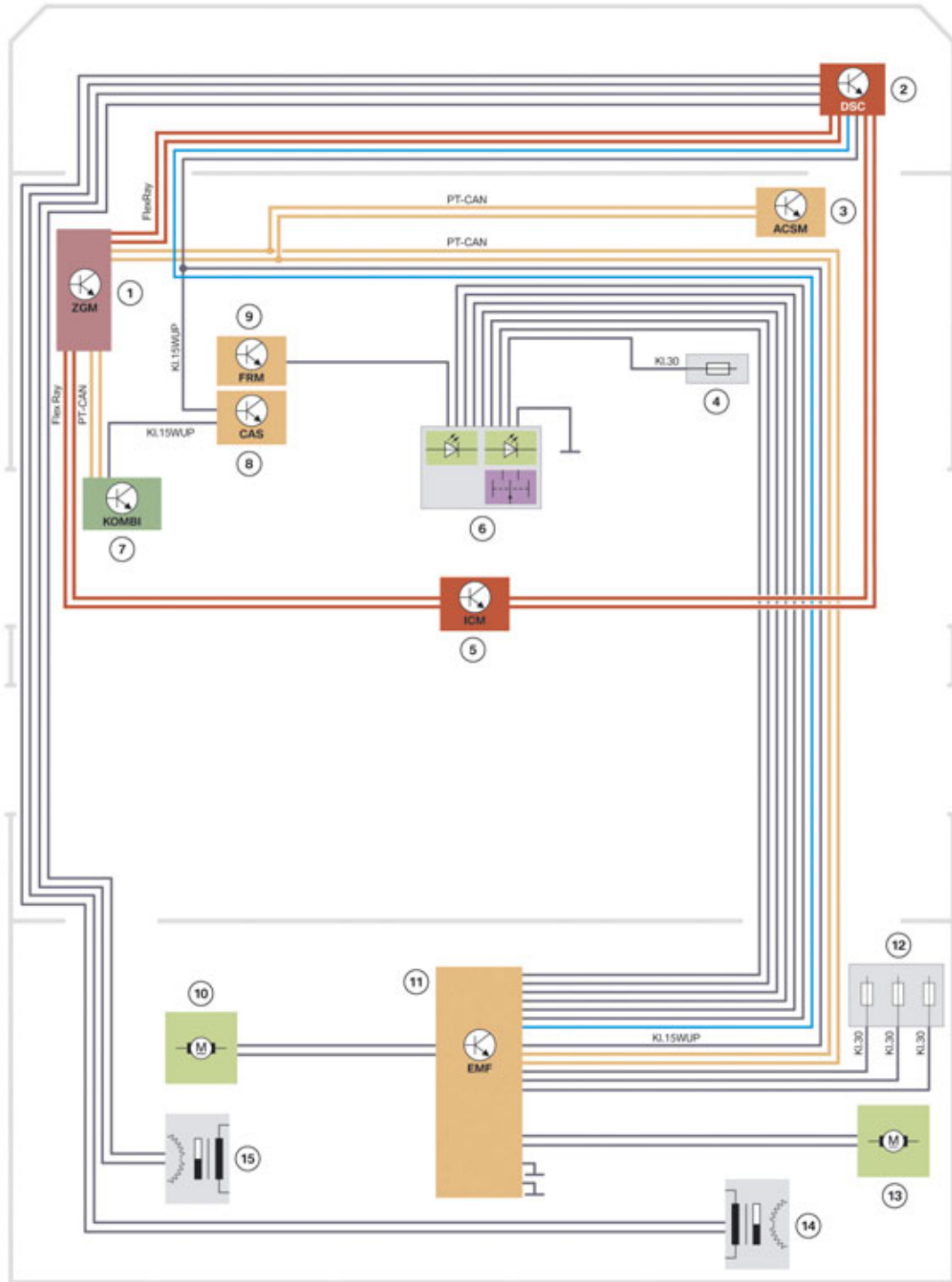

TF10-0805

F25 EMF system wiring diagram

F25 Chassis Dynamics

4. Brakes

Index	Explanation
1	Central gateway module (ZGM)
2	Dynamic Stability Control (DSC)
3	Advanced Crash Safety Module
4	Junction box power distribution box
5	Integrated Chassis Management (ICM)
6	Parking brake button
7	Instrument panel (KOMBI)
8	Car Access System (CAS)
9	Footwell module (FRM)
10	EMF actuator, rear left
11	EMF control unit
12	Power distribution box, luggage compartment
13	EMF actuator, rear right
14	Wheel speed sensor, rear right
15	Wheel speed sensor, rear left
Terminal 30	Terminal 30
Terminal 15 wake-up	Wake-up with terminal 15 ON

4.2.3. System structure

The EMF control unit receives the driver's instruction to apply the parking brake from the parking brake button. The vehicle condition is queried/detected via the electrical system connection and the bus systems. The EMF control unit decides whether all the pre-conditions for the parking brake sequence are satisfied. If so, the two EMF actuators on the rear brake calipers are operated.

F25 Chassis Dynamics

4. Brakes

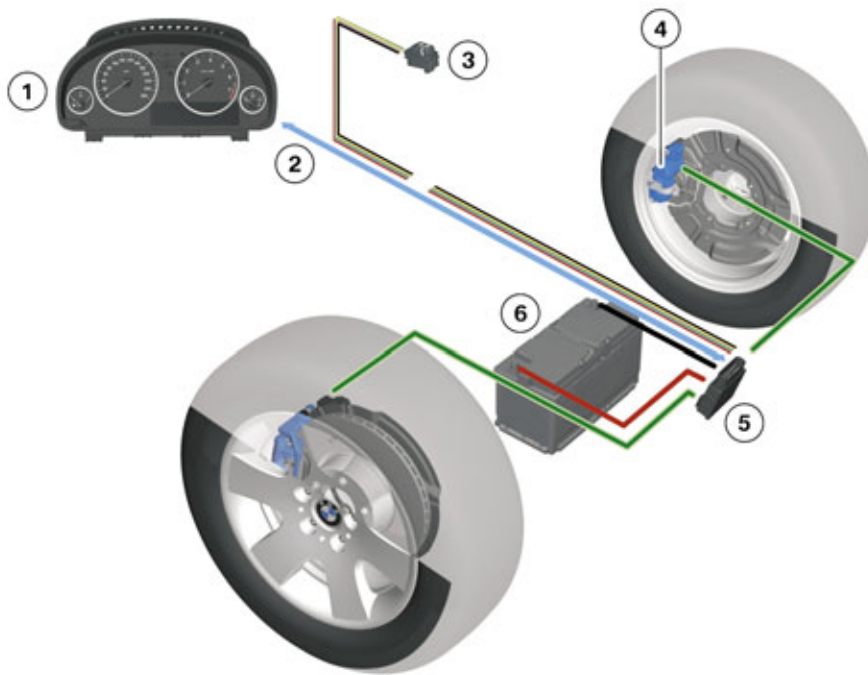

TF10-1061

F25 Operating principle of EMF

Index	Explanation
1	Instrument panel (KOMBI)
2	Information flow
3	Parking brake button
4	EMF actuator
5	EMF control unit
6	Battery

4.2.4. System function

Due to the spindle's self-locking facility, the clamping force remains securely applied even when no power supply is connected, and the vehicle is thus securely held. Once the required force is reached, the parking brake applied status is indicated by a red indicator lamp on the instrument panel and an additional red LED in the parking brake button. If the vehicle's parking brake is already applied, pulling the parking brake button again has no effect.

The driver applies the vehicle's parking brake by pulling out the parking brake button. The operating direction of the button is the same as the operating direction for a mechanical parking brake lever. The signal from the parking brake button is read by the EMF control unit. The EMF control unit operates the EMF actuators on the rear brake calipers individually.

The parking brake can be applied in any logical terminal status. Parking brake application in Terminal 0 status is made possible by the connection from Terminal 30 to the EMF control unit. If the driver operates the parking brake button in Terminal 0 status, the EMF control unit is woken up. The EMF con-

F25 Chassis Dynamics

4. Brakes

control unit then wakes up the other control units on the vehicle. Only then does the EMF control unit receive the essential information about vehicle standstill. In addition, the change of parking brake status can also be indicated once the system has been woken up.



F25 Indicator lamp for parking brake applied

Design and function of EMF actuator

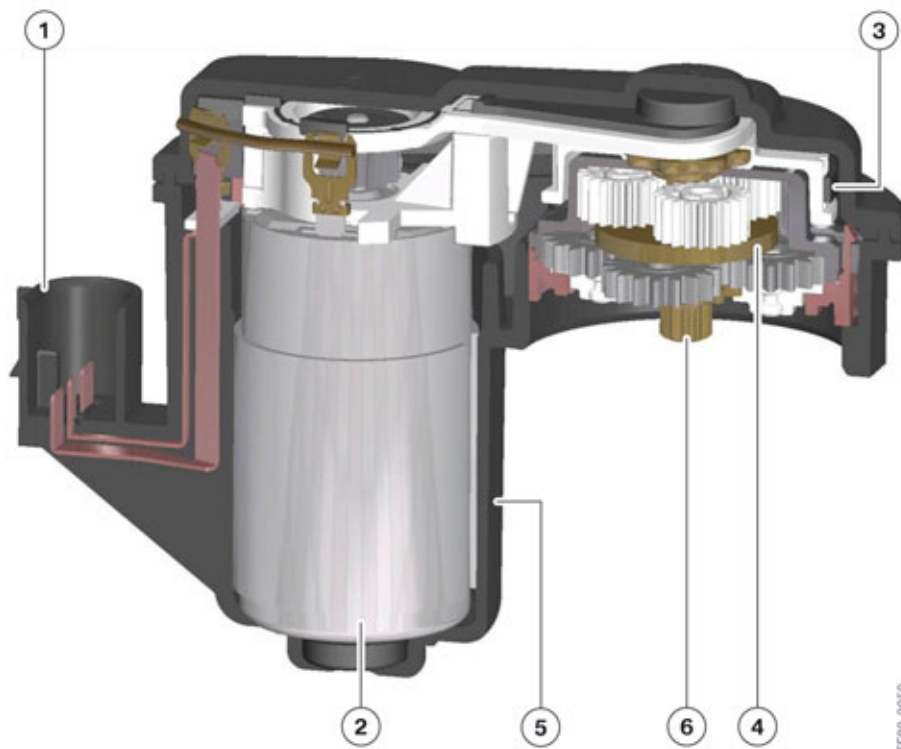

F25 Design of EMF actuator

Index	Explanation
1	Plug connection
2	Electric motor
3	Drive belt
4	Planetary gear train
5	Housing
6	Connection to spindle

The EMF actuator is fixed to the brake caliper and acts directly on the brake piston.

F25 Chassis Dynamics

4. Brakes

The force is transmitted to a two-stage planetary gear train (4) by an electric motor (2) and a belt drive system (3). The spindle illustrated in the graphic below is driven via the connection to the spindle (6).

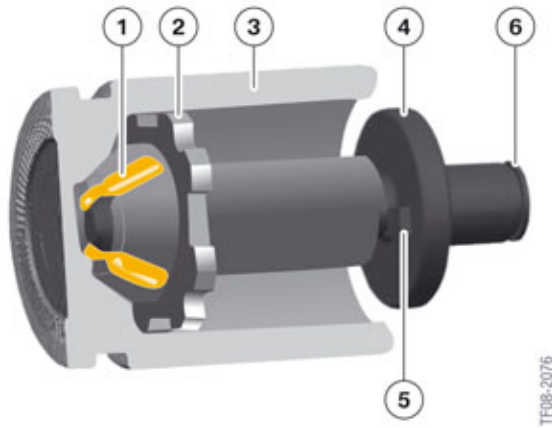

F25 Spindle and spindle nut in brake piston

Index	Explanation
1	Groove
2	Spindle nut with anti-twist lock
3	Brake piston
4	Spindle
5	Spindle end stop
6	Connection to planetary gear train

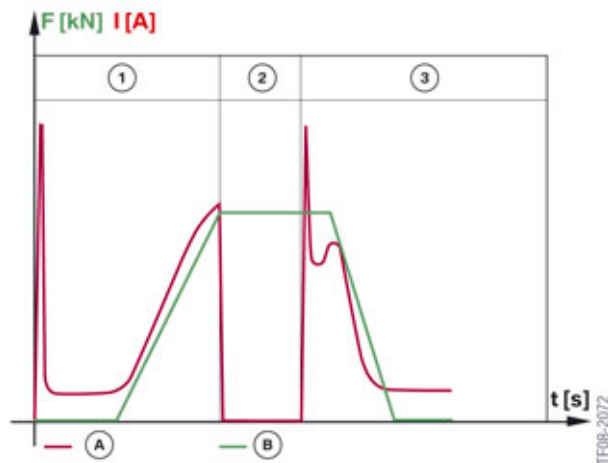

F25 EMF current and force flow

F25 Chassis Dynamics

4. Brakes

Index	Explanation
A	Current flow
B	Force flow
1	Applying parking brake
2	Parking brake applied
3	Releasing parking brake

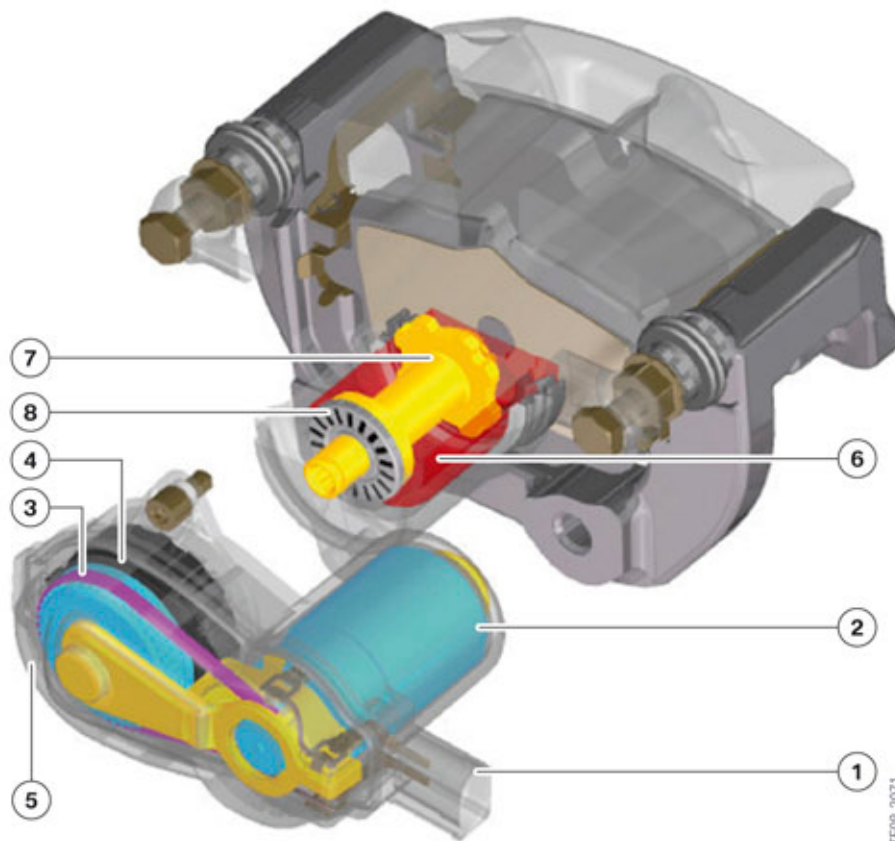

F25 Overview of EMF actuator and brake caliper

Index	Explanation
1	Plug connection
2	Electric motor
3	Drive belt
4	Planetary gear train
5	Housing
6	Brake piston
7	Spindle and spindle nut
8	Roller bearing

F25 Chassis Dynamics

4. Brakes

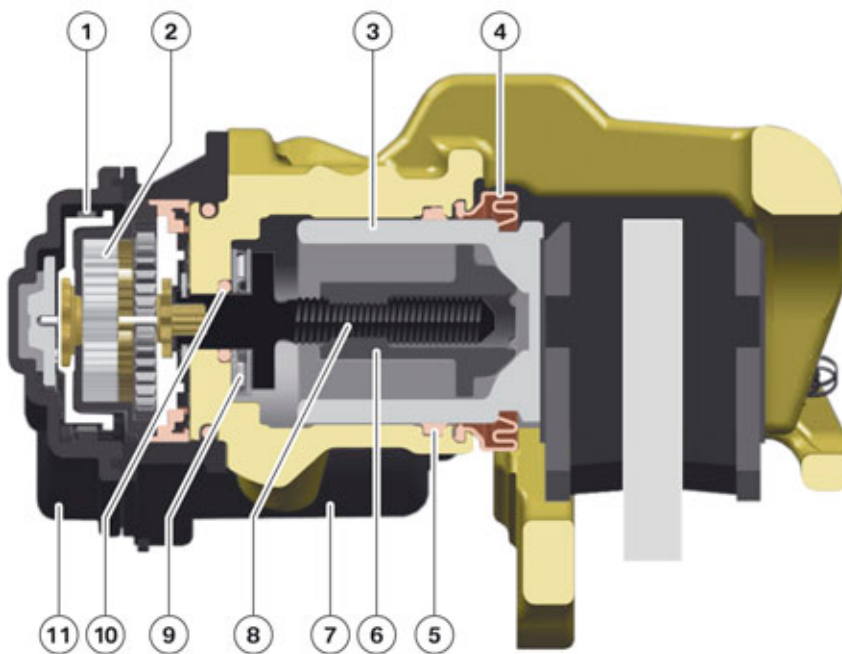

F25 Parking brake applied with new brake pads

Index	Explanation
1	Drive belt
2	Planetary gear train
3	Brake piston
4	Dust boot
5	Sealing ring
6	Spindle nut
7	Electric motor
8	Spindle
9	Roller bearing
10	Sealing ring
11	Housing

Roll-away detection while parking brake applied

The roll-away detection function is designed to prevent the vehicle rolling away while the parking brake is applied. The roll-away detection function is always activated whenever the parking brake status changes from "released" to "applied" and terminates after a defined period of time from that change of status.

A signal from the DSC control unit is used as the input variable for roll-away detection. As soon as that signal indicates that the vehicle is starting to roll during the detection window, the EMF actuators are immediately further tightened. That is achieved by applying maximum current to the EMF actuators for 100 ms in order to increase the clamping force. The system then waits for 400 ms. If the vehicle starts

F25 Chassis Dynamics

4. Brakes

to roll again, the retightening process is repeated (up to three times). If rolling of the vehicle is still detected after retightening the parking brake three times, the function terminates with a fault entry in the fault memory.

Temperature monitoring

The temperature monitoring function ensures that the loss of parking-brake force that occurs when hot brake discs cool down is compensated for. The temperature monitoring function is activated if the temperature is above a defined value on a change of parking brake status from "released" to "applied".

The temperature of the brake discs is calculated individually for each wheel by the DSC control unit and communicated to the EMF control unit. When the status change takes place, the higher of the two brake disc temperatures is applied for temperature monitoring purposes. The temperature ranges and corresponding retightening periods are stored in a characteristic map.

The appropriate retightening periods from the characteristic map are applied according to the temperature on change of status. Once the first retightening period has elapsed, the parking brake is retightened for the first time. After expiry of the second retightening period, the parking brake is retightened again, and again after the third period has elapsed. The characteristic map may also contain the value 0 for one or more retightening periods. In that case, the corresponding retightening sequences do not take place. The function terminates when the last retightening sequence has been completed.

Releasing the parking brake

The parking brake is released by pressing the parking brake button down. However, for the parking brake to actually be released, Terminal 15 must be ON and at least one of the following preconditions satisfied:

- Brake pedal applied, or
- Automatic transmission parking lock engaged.

That prevents the vehicle starting to roll when not intended, e.g. if another occupant apart from the driver presses the parking brake button. Once the parking brake is released, the red indicator lamp on the instrument panel and the red LED in the parking brake button go out.

Activation of the EMF actuator sets the spindle in motion. The rotation of the spindle moves the spindle nut a small, defined distance away from the brake piston.

Dynamic emergency braking

The law requires that there are two operating facilities for the brakes. On the F25, the second operating facility after the brake pedal is the parking brake button in the center console. If the parking brake button is pulled up while the vehicle is moving, a dynamic emergency braking operation with a defined procedure is performed by the DSC system. This function is intended for emergency situations in which the driver is not able to brake the vehicle using the brake pedal. Other occupants can also bring the vehicle to a standstill in this way if, for example, the driver suddenly falls unconscious.

During dynamic emergency braking, brake pressure is generated hydraulically at all four wheel brakes. The DSC functions are fully active and the brake lights are operated. That represents a fundamental advantage over manual parking brakes.

F25 Chassis Dynamics

4. Brakes

The dynamic emergency braking sequence only remains in effect while the parking brake button is being pulled. The level of deceleration applied by the DSC is steeply increased. During dynamic emergency braking the EMF indicator light on the instrument panel is activated. In addition, a Check Control message is displayed along with an acoustic signal in order to draw the driver's attention to the special situation.

If the driver simultaneously brakes by pressing the brake pedal and pulling the parking brake button, the DSC control unit prioritizes. The greater deceleration demand is put into effect. If dynamic emergency braking is continued until the vehicle is at a standstill, the vehicle remains braked even after the parking brake button is released. The EMF indicator light on the instrument panel remains on. The driver can then release the parking brake (see "Releasing the parking brake").

Parking brake fault

If a fault occurs on the parking brake, the EMF indicator lamp on the instrument panel shows yellow. A Check Control message is displayed.



F25 Indicator light showing parking brake fault

Emergency release

Emergency release of the parking brake by the customer is not provided for.

The parking brake can be released by unscrewing the EMF actuators and manually screwing back the spindle.

Replacing brake pads

To replace the brake pads the EMF actuator must be in the fully released position so that the brake piston can be pressed back. The EMF actuators can be activated via the diagnosis system and moved to the fully released position. That position is required in order to be able to change the brake pads. Once the installation position is reached, installation mode is automatically activated.

F25 Chassis Dynamics

4. Brakes

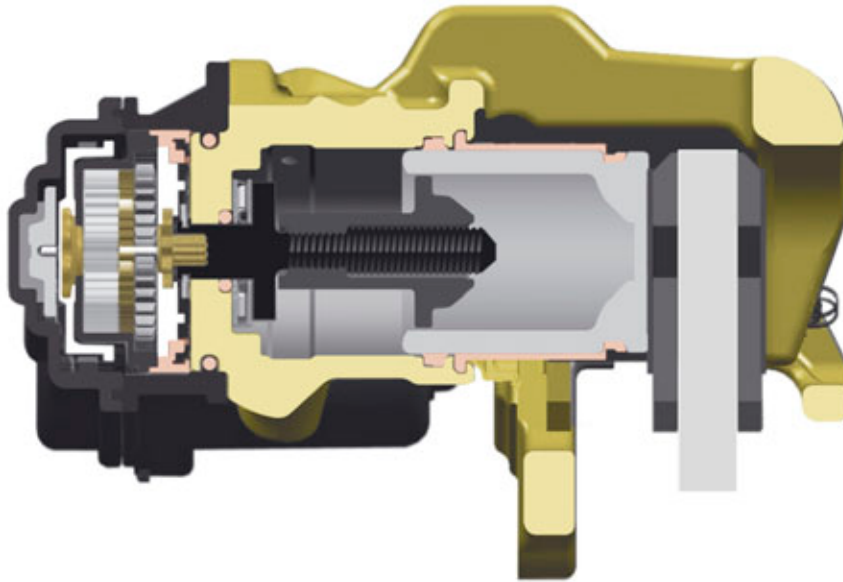

F25 EMF with spindle nut in working position for replacing brake pads



As long as the EMF control unit is in installation mode, the parking brake cannot be applied for safety reasons. If the parking brake button is nevertheless operated, the EMF indicator lamp on the instrument panel (KOMBI) flashes yellow.

Installation mode can be cancelled in two ways:

- By executing the service function "Reset installation mode" with the aid of ISTA
- By driving the vehicle and exceeding a programmed minimum speed.

Brake test stand detection

The EMF control unit detects that the vehicle is on a brake test stand by means of a plausibility check (comparison of wheel speeds) and switches to brake test stand mode. Identification takes about 6 seconds.

Pulling the parking brake button several times in sequence sets the parking brake to the following positions:

- Brake pads in contact
- Force level 1 for brake test stand
- Force level 2 for brake test stand
- Target force.

Alternatively, the parking brake button can be held continuously in the pulled-out position while brake test stand mode is active. The parking brake is then moved to the individual defined positions in sequence at intervals of 3 seconds.

F25 Chassis Dynamics

4. Brakes

When brake test stand mode is active and the EMF actuators are released, the parking brake indicator light flashes slowly.

When brake test stand mode is active and the EMF actuators are partially applied, the parking brake indicator light starts to flash more quickly.

When the vehicle is on a brake test stand, the parking brake can be released without having to press the brake or clutch pedal. Brake test stand mode is automatically cancelled when the vehicle is driven off the brake test stand. It is also deactivated if the parking brake button is pressed in or if a fault is present.

4.2.5. Check Control messages

EMF indicator light	Check Control symbol
	-
Description	EMF is applied mechanically
Check control message	-
Central Information Display	-



EMF indicator light	Check Control symbol
	-
Description	EMF is in installation mode - the parking brake button is operated simultaneously
Check control message	-
Central Information Display	-



EMF indicator light	Check Control symbol
	-
Description	Brake test stand detected – actuator released
Check control message	-
Central Information Display	-

F25 Chassis Dynamics

4. Brakes

EMF indicator light	Check Control symbol
	-
Description	Brake test stand detected – actuator in intermediate position
Check control message	-
Central Information Display	-

EMF indicator light	Check Control symbol
	
Description	EMF is applied mechanically - the driver attempts to drive off at the same time
Check control message	Release parking brake!
Central Information Display	-

EMF indicator light	Check Control symbol
	
Description	Parking brake button is applied during the journey (dynamic emergency braking)
Check control message	Release parking brake!
Central Information Display	-

F25 Chassis Dynamics

4. Brakes



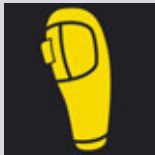

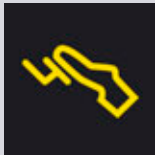
EMF indicator light	Check Control symbol
-	
Description	The driver attempts to release the EMF without having depressed the brake pedal - the selector lever is not in position P
Check control message	Press foot brake as well!
Central Information Display	-

EMF indicator light	Check Control symbol
-	
Description	The driver attempts to release the EMF - the selector lever is not in position P
Check control message	Also engage transmission P
Central Information Display	To release parking brake, also engage transmission position P.

EMF indicator light	Check Control symbol
-	
Description	The driver attempts to release the EMF - the brake or clutch pedal are not operated
Check control message	Press foot brake or clutch pedal!
Central Information Display	Also press foot brake or clutch pedal to release the parking brake.





F25 Chassis Dynamics

4. Brakes

EMF indicator light	Check Control symbol
	-
Description	"New" fault occurs at parking brake button OR Fault pending at parking brake button with simultaneous operation
Check control message	-
Central Information Display	-
EMF indicator light	Check Control symbol
	
Description	Fault detected at parking brake button - no restriction in functionality at present
Check control message	Availability of parking brake restricted
Central Information Display	Availability of parking brake restricted Have vehicle checked by your BMW Service authorized workshop.
EMF indicator light	Check Control symbol
	
Description	At least one speed signal is no longer available - no restriction in functionality at present
Check control message	Availability of parking brake restricted
Central Information Display	Availability of parking brake restricted Have vehicle checked by your BMW Service authorized workshop.



F25 Chassis Dynamics

4. Brakes

EMF indicator light	Check Control symbol
	
Description	Dynamic emergency braking no longer available
Check control message	Availability of parking brake restricted
Central Information Display	Availability of parking brake restricted Parking brake can be applied and released using button when stationary. It is not possible to brake the vehicle when it is in motion using the parking brake. Have vehicle checked by your BMW Service authorized workshop.
EMF indicator light	Check Control symbol
	
Description	Mechanical application of the parking brake is no longer available OR Dynamic emergency braking and mechanical parking brake application are no longer available
Check control message	Parking brake has failed
Central Information Display	Parking brake has failed To park, secure vehicle to prevent it rolling. Have vehicle checked by your BMW Service authorized workshop.

F25 Chassis Dynamics

4. Brakes

EMF indicator light	Check Control symbol
	
Description	Mechanical application of the parking brake is no longer available OR Dynamic emergency braking and mechanical parking brake application are no longer available
Check control message	Parking brake has failed!
Central Information Display	Parking brake has failed. To park, secure vehicle to prevent it rolling. Have vehicle checked by your nearest BMW Service authorized workshop.

F25 Chassis Dynamics

5. Steering

5.1. Electronic Power Steering EPS

The F25 xDrive is the first mass-produced vehicle with xDrive to be equipped with Electronic Power Steering EPS (electromechanical power steering) which replaces the conventional hydraulic power steering.

In contrast to hydraulic power steering, with EPS steering the servo forces are applied to the rack via an electric motor and a reduction gear.

This has achieved an average reduction in fuel consumption of roughly 0.3 l per 100 km when compared to conventional hydraulic power steering. That helps to reduce the carbon dioxide emissions. As there is no oil in the EPS, it is environmentally cleaner and more service friendly than conventional hydraulic power steering.

Compared to conventional hydraulic power steering, the installation and maintenance cost has been significantly reduced thanks to the compact design of the steering box with integrated electric motor and control electronics.

With EPS steering, the steering servo (steering forces) and also the return characteristics are freely configurable. This means that the steering and drivability can be adapted optimally to the relevant driving situation (e.g. when driving in the city or on the highway).

Servotronic, i.e. steering servo dependent on vehicle speed, is available as optional equipment (SA 216).

If a driving dynamics control switch is installed - two different settings, "Normal" or "Sporty" can be accessed with the following optional equipment:

- EDC (SA 223)
- Sports steering (SA 2VL)
- Servotronic (Standard)
- Steptronic sport automatic transmission (SA 2TB)

Although Active Steering is not provided for in the F25, "Variable sport steering" (SA 2VL) is available as the optional equipment.

F25 Chassis Dynamics

5. Steering



F25 EPS steering components

Index	Explanation
1	Electronic Power Steering EPS
2	Steering column
3	Steering wheel

F25 Chassis Dynamics

5. Steering

5.1.1. System overview

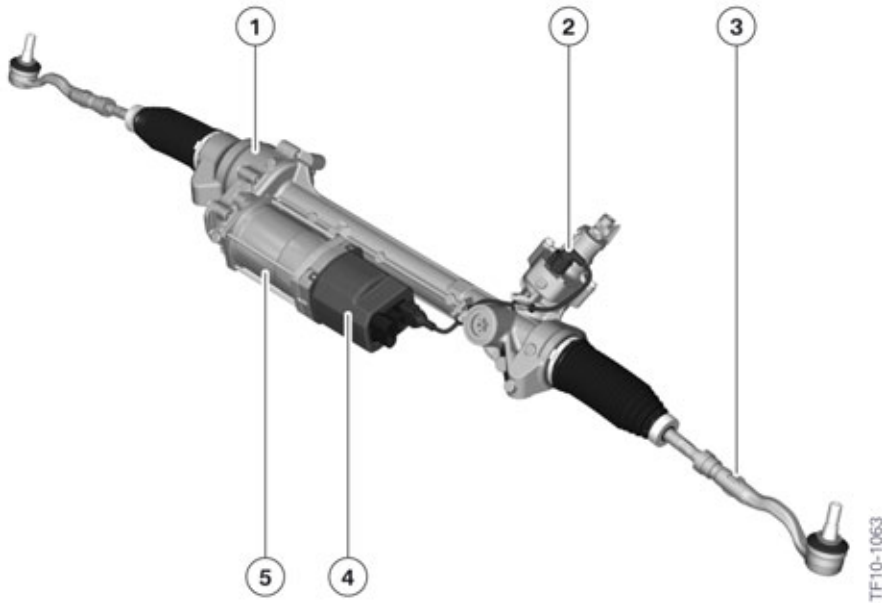

F25 EPS steering box

Index	Explanation
1	Reduction gear
2	Steering-torque sensor
3	Track rod
4	EPS control unit
5	Electric motor with rotor position sensor

F25 Chassis Dynamics

5. Steering

5.1.2. System wiring diagram

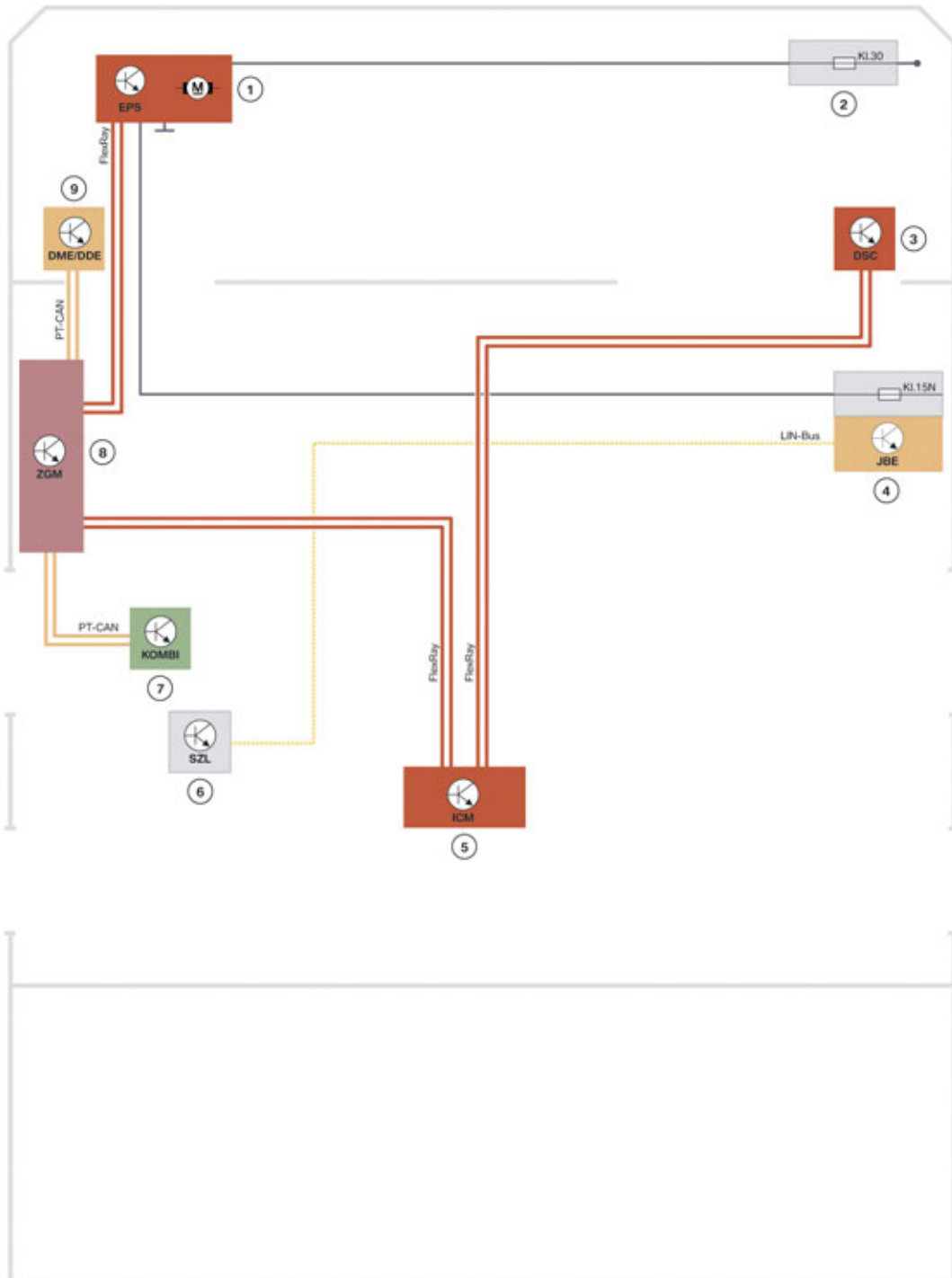

F25 EPS system wiring diagram

TF10-0804

F25 Chassis Dynamics

5. Steering

Index	Explanation
1	Electronic Power Steering (EPS)
2	Power distribution box, engine compartment
3	Dynamic Stability Control (DSC)
4	Junction box power distribution box
5	Integrated Chassis Management (ICM)
6	Steering column switch cluster (SZL)
7	Instrument panel (KOMBI)
8	Central gateway module (ZGM)
9	Digital Motor Electronics (DME)
KI.30	Terminal 30
KI.15N	Ignition (after-run)
LIN bus	Local interconnect network bus

5.1.3. Steering angle sensor

In the F25, information on the steering angle is not acquired via the Electronic Power Steering EPS from a separate sensor at the steering wheel and is instead deduced from the motor position angle of the EPS motor in relation to the steering wheel.

The EPS reports the position of the rack via FlexRay to the ICM control unit. In this case the EPS calculates the absolute position of the rack based on the current position of the EPS motor rotor and the number of full rotor revolutions from the neutral position (corresponds to straight-ahead driving).

Taking this position as the starting point, the ICM control unit determines, among other things, the steering angle in relation to the wheel using the stored gear ratio parameters (between the rack and steering angle in relation to wheel) and transmits these via FlexRay. This wheel-specific steering angle is used by the Dynamic Stability Control and other systems as a reference variable for internal control functions.

In cases where the absolute value is not available from the EPS (terminal 30 loss, flashing process), the absolute value is determined through interaction of the ICM and EPS via a teach-in function by steering from end stop to end stop (e.g. straight-ahead position -> left -> right -> straight-ahead position).

5.2. Variable sport steering

The optional equipment "Variable sport steering" (SA 2VL) is available for the F25 as an alternative to the basic version of the EPS. This is the first steering system available on the market to combine the benefits of an extremely direct, variable steering gear ratio with the operating principle of EPS steering.

The variable sport steering increases ride comfort and also agility. The direct ratio reduces the total steering angle, i.e. the number of steering wheel revolutions from steering stop to steering stop, by roughly 25%. This therefore increases comfort during driving manoeuvres that require larger steering angles, e.g. when parking, turning off or turning.

F25 Chassis Dynamics

5. Steering

Compared to the basic version of the EPS steering, the vehicle responds more directly and has greater agility owing to the more direct steering gear ratio and the resulting lower required steering angle. This is effective during avoidance manoeuvres, for example.

The variable steering gear ratio is achieved by using a displacement-dependent rack gearing geometry. When roughly in the center position of the steering box, the steering responds precisely with stable directional stability. As the steering angles move out of the center position, the ratio becomes increasingly more direct.

5.2.1. System overview

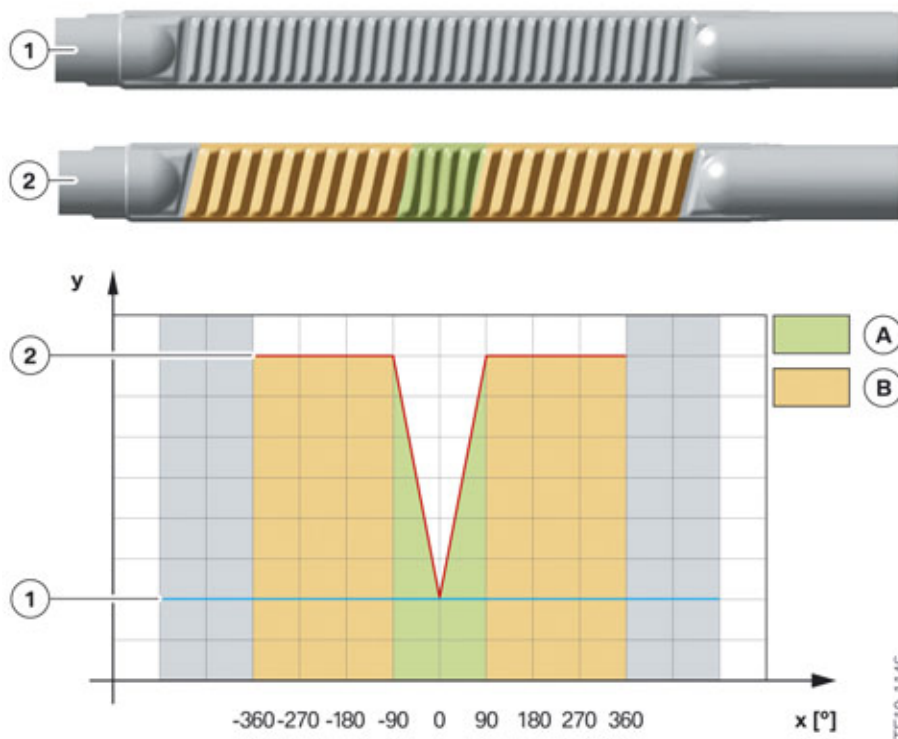

F25 Comparison between steering gear ratio of EPS steering basic version and variable sport steering

Index	Explanation
1	Rack, EPS basic version (constant gearing geometry)
2	Rack, variable sport steering (variable gearing geometry)
A	More indirect steering gear ratio (variable sport steering)
B	More direct steering gear ratio (variable sport steering)
x	Steering angle
y	Steering gear ratio

F25 Chassis Dynamics

5. Steering

5.3. Steering column

5.3.1. Steering column adjustment

The length and height of the steering column of the F25 can be mechanically adjusted. This is required for the driver to achieve an optimum ergonomic driving position.

F25 Chassis Dynamics

6. Driving stability control systems

6.1. Directions of action

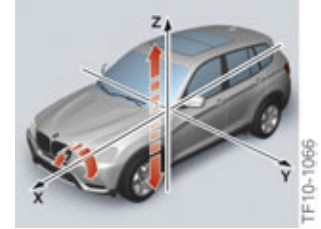
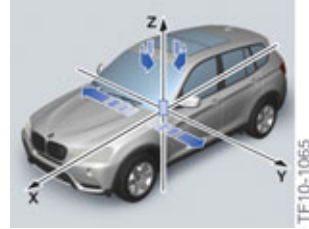
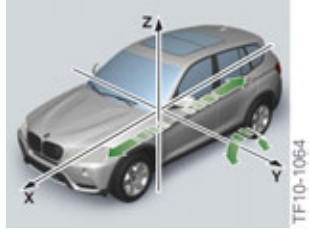

Direction of action	Longitudinal	Pitch	Lateral	Yaw	Vertical	Roll
DSC	●		●	●		●
EDC	●	●	●		●	●
DCC	●					

Driving stability control systems are differentiated according to their basic effective directions. Dynamic handling control systems may act along as well as around an axis of the vehicle coordinate system (X, Y or Z).

6.2. Integrated Chassis Management (ICM)

6.2.1. System overview

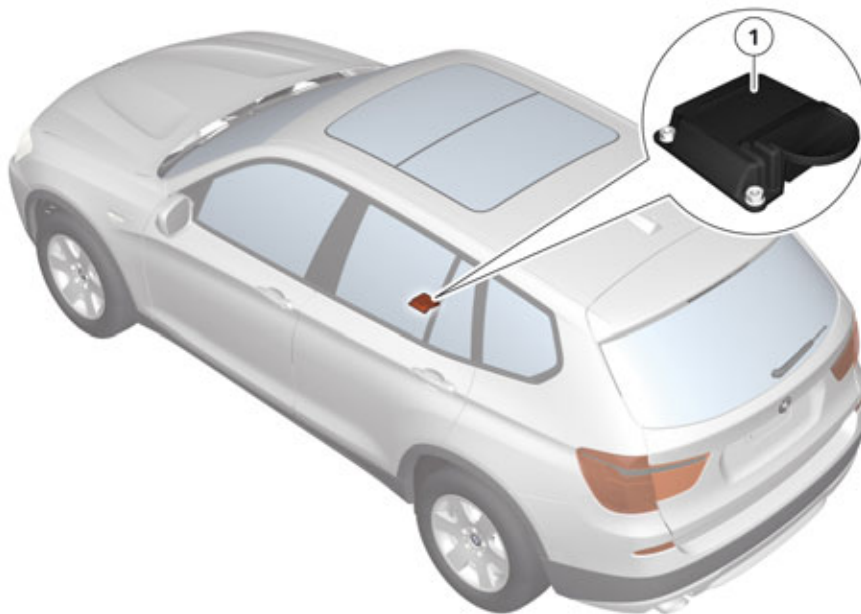

TF10-1081

F25 ICM control unit ICM

F25 Chassis Dynamics

6. Driving stability control systems

Index	Explanation
1	ICM control unit

The ICM control unit is installed on the center console by means of a holder. It contains the driving dynamics sensor system and central sensor system for the airbag.

6.2.2. System function

Influence of the ICM control unit on driving stability control in detail:

- **Performance Control (SA 2VG)**
Selective braking at the rear inner cornering wheel makes a more neutral self-steering response possible and reduces the tendency to understeer. For the duration of braking intervention, the output of the engine is increased proportionally so this is not perceived as deceleration. The setpoint is calculated in the ICM control unit and put into action in the Dynamic Stability Control. (For more information, refer to sections 6.4 and 6.5 of this training material.)
- **Driving dynamics control**
The driver can use the operating elements DTC button or driving dynamics control switch (DTC mode, Dynamic Stability Control OFF) to activate the driving dynamics control FDR. The function mode is displayed via the instrument panel (KOMBI).
Evaluation of the DTC button and driving dynamics control switch as well as the changeover logic, including communication with the systems involved (including DSC), takes place in the ICM control unit. In addition, the ICM control unit incorporates system monitoring of partner functions that changes back to normal mode when one of the functions being monitored drops out (DSC ON).
- **Hill Descent Control HDC**
The purpose of HDC is to support the driver when driving downhill. When the driver activates this function by pushing the button, the vehicle travels on downhill gradients at a constant speed defined by the driver of between roughly 5 and 25 km/h. If the actual speed is not the same as the reference speed set by the driver, the HDC attempts by means of harmonious control to match the two speeds. The driver is supported by the DSC control functions during this process.



If the driver operates the HDC button, the ICM control unit checks this operation against the current states of the other assist systems.

- **Dynamic Cruise Control**
The Dynamic Cruise Control DCC is a road speed controller that incorporates brake intervention. The DCC function in the ICM control unit acts on the powertrain and brake via the corresponding interfaces. In addition, interfaces for display and operating elements and for the driving dynamics sensor system exist. (For more information, refer to section 6.6.)

F25 Chassis Dynamics

6. Driving stability control systems

The ICM control unit contains the following sensors, depending on the vehicle equipment:

Function	Vehicles with out EDC	Vehicles with EDC
Longitudinal acceleration (airbag sensor system)	●	●
Lateral acceleration (airbag sensor system)	●	●
Longitudinal acceleration	●	●
Lateral acceleration	●	●
Vertical acceleration	●	●
Roll rate	●	●
Pitch rate	-	●
Yaw rate	●	●

The information from these sensors is used to calculate the following signals which are made available to the Dynamic Stability Control DSC via FlexRay:

- Yaw rate
- Lateral acceleration
- Longitudinal acceleration
- Steering angle.

6.3. Dynamic Stability Control DSC

The Dynamic Stability Control DSC is at the heart of suspension control systems that are designed to increase active safety. It optimizes driving stability under all driving conditions and also traction when driving off and accelerating. In addition, it detects unstable driving conditions such as understeering or oversteering and helps keep the vehicle safely on course.

To this end the current driving conditions are permanently recorded by the highly sensitive sensors of the DSC. The information acquired comes from the wheel speed, steering angle, lateral acceleration, longitudinal acceleration, pressure and yaw sensors (rotation around the vertical axis of the vehicle), for example. The single-track model calculated from this information in the DSC control unit serves as the basic parameter for regulatory intervention by the DSC. During this process, a comparison is made between the corresponding driver input (steering wheel angle and vehicle speed).

If the measured actual condition deviates from the calculated reference condition, action is taken to improve stability and/or traction. This involves selective actuation of the engine and brake management as well as the xDrive. The driving stability can be ensured once again or a traction request can be implemented by selectively reducing or increasing the engine torque (with active engine drag torque control or Performance Control) or brake intervention at individual wheels.

F25 Chassis Dynamics

6. Driving stability control systems

6.3.1. System overview

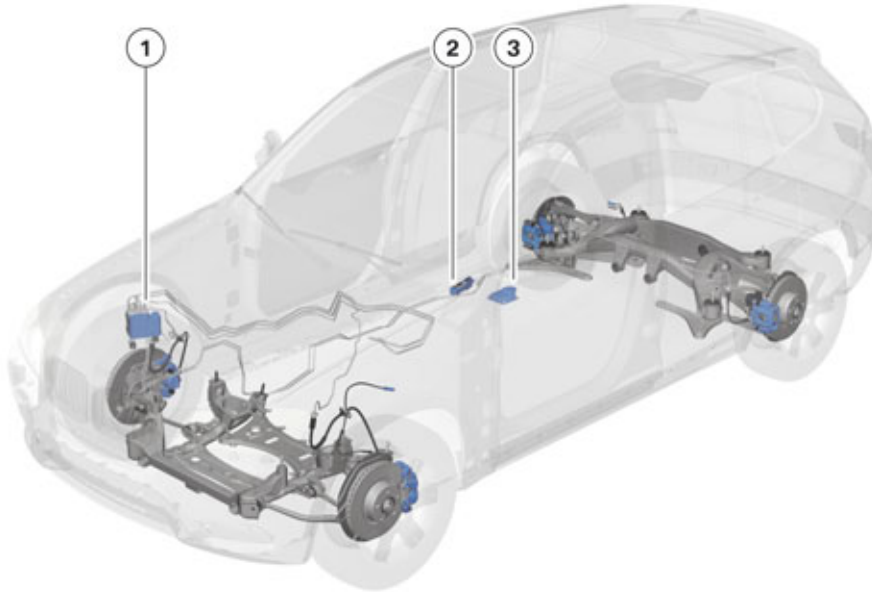

TF10-1136

F25 System overview, DSC

Index	Explanation
1	Dynamic Stability Control DSC
2	Center console operating facility
3	Integrated Chassis Management ICM

F25 Chassis Dynamics

6. Driving stability control systems

6.3.2. System wiring diagram

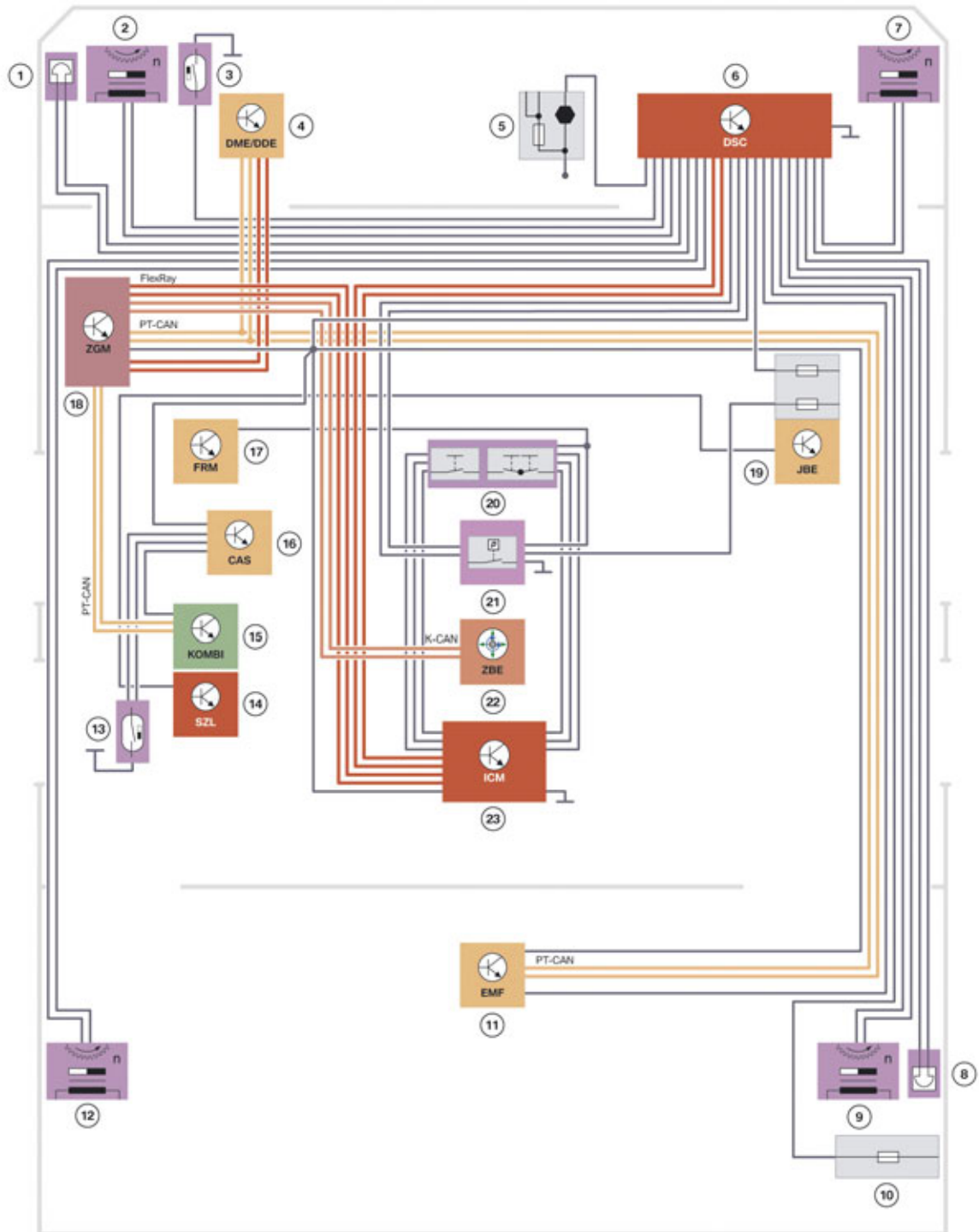

F25 System wiring diagram, DSC

TF10-0907

F25 Chassis Dynamics

6. Driving stability control systems

Index	Explanation
1	Brake pad wear sensor, front left
2	Wheel speed sensor, front left
3	Brake fluid level switch
4	Digital Motor Electronics (DME)
5	Junction box power distribution box
6	Dynamic Stability Control (DSC)
7	Front right wheel speed sensor
8	Rear right brake pad wear sensor
9	Rear right wheel speed sensor
10	Luggage compartment power distribution box
11	EMF control unit
12	Wheel speed sensor, rear left
13	Brake light switch
14	Steering column switch cluster (SZL)
15	Instrument panel (KOMBI)
16	Car Access System CAS
17	Footwell module FRM
18	Central Gateway Module
19	Junction box electronics
20	Center console operating facility
21	Parking brake button
22	Central operating element
23	Integrated Chassis Management ICM

Function	Sub-function	Designation
ABS		Antilock Brake System
	EBV	Electronic brake force distribution
	CBC	Cornering Brake Control
	DBC	Dynamic Brake Control
ASC		Automatic Stability Control
	ADB-X	Automatic Differential Brake
	MMR	Engine torque control
	MSR	Engine drag control
	BMR	Braking torque control
DSC		Dynamic Stability Control

F25 Chassis Dynamics

6. Driving stability control systems

Function	Sub-function	Designation
	AKR	Anti-tilt control
		Trailer Stability Control (Not for US)
	DTC	Dynamic Traction Control
		Performance Control
HDC		Hill Descent Control HDC

The DSC can be operated in three modes:

- Dynamic Stability Control ON
- Dynamic traction control, DTC
- DSC OFF

Function	DSC ON	DTC	DSC OFF
Antilock Brake System (ABS)	●	●	●
Electronic brake force distribution	●	●	●
Cornering Brake Control (CBC)	●	●	●
Engine drag torque control (MSR)	●	●	●
Automatic Stability Control (ASC)	●	x	-
Hill Descent Control (HDC)*	●	●	●
Automatic Differential Brake (ADB-X)	●	●	●
Driving dynamics control (FDR)*	●	x	-
Anti-tilt control (AKR)	●	●	●
Trailer Stability Control	●	●	-
Performance Control	●	●	●
Brake standby	●	●	●
Rain brake support	●	●	●
Drive-off assistant	●	●	●
Fading Brake Support	●	●	●
Dynamic Braking Control (DBC)	●	●	●
Automatic Hold together with the Electromechanical Parking Brake (EMF)*	●	●	●
Run Flat Indicator (RPA)	●	●	●
Condition Based Services (CBS)	●	●	●
xDrive function	●	●	●

F25 Chassis Dynamics

6. Driving stability control systems

Symbol	Explanation
●	Function active
-	Function not active
x	Function with adapted control thresholds
*	Can be switched on and off by the driver



Adopting a suitably adapted driving style always remains the responsibility of the driver.

Not even DSC can overcome the laws of physics.

The additional safety features of the system should not be diminished by risky driving.

F25 Chassis Dynamics

6. Driving stability control systems

6.4. xDrive

6.4.1. System overview

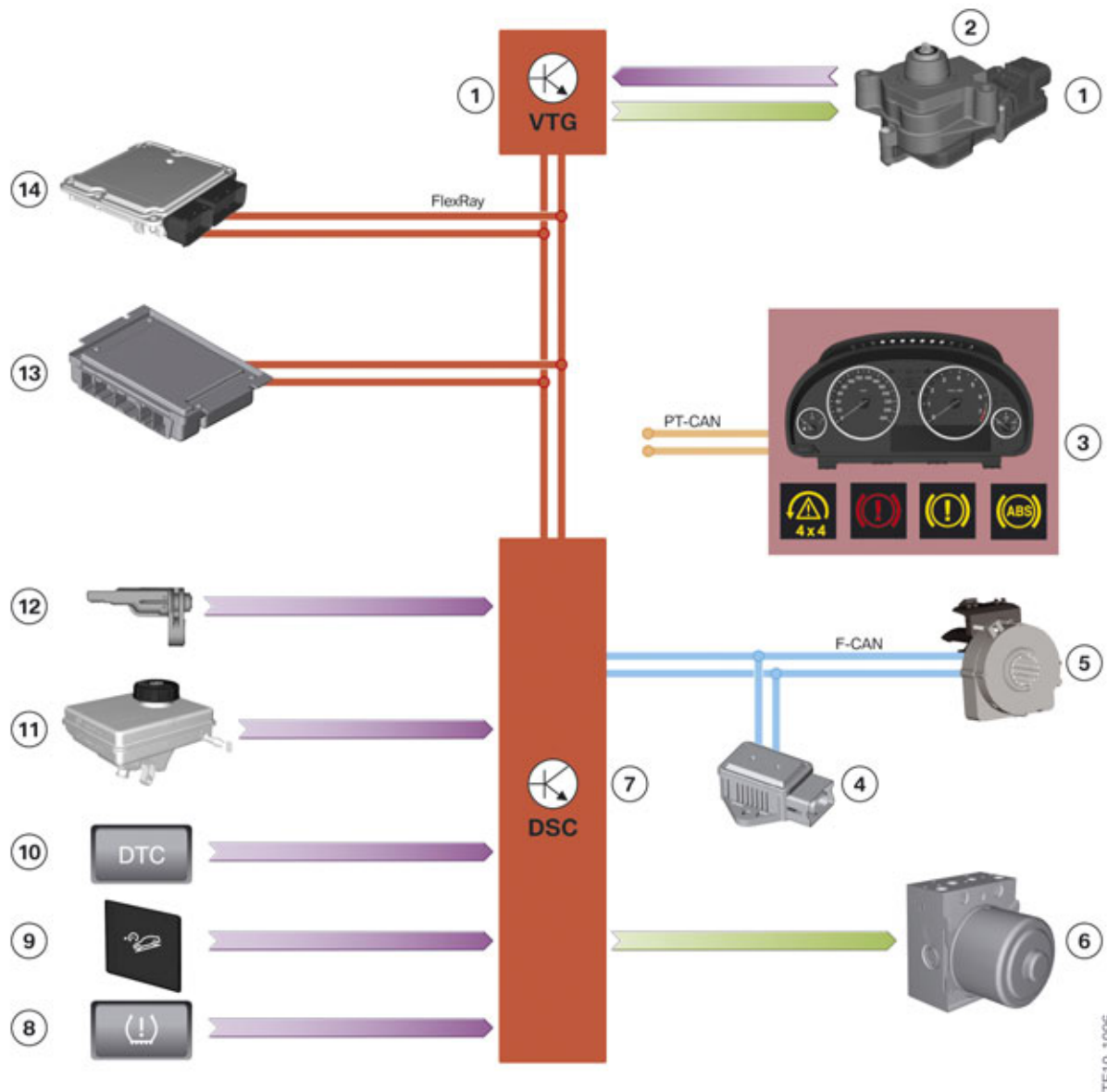

F25 xDrive system overview

Index	Explanation
1	Transfer box (VTG) control unit
2	Actuator for transfer box coupling
3	Instrument panel (KOMBI)
4	DSC sensor (lateral acceleration, longitudinal acceleration and yaw sensor)

F25 Chassis Dynamics

6. Driving stability control systems

Index	Explanation
5	Steering angle sensor
6	DSC hydraulic unit
7	DSC control unit
8	Run Flat Indicator button
9	HDC button
10	DTC button
11	Brake fluid level switch
12	Wheel speed sensor
13	Electronic transmission control (EGS)
14	Digital Motor Electronics (DME)

The intelligent BMW xDrive four-wheel drive permanently distributes the drive torque between the front and rear axle via an electronically-controlled multi-disc clutch.

The F25 features the new ATC 450 transfer box which has been optimized in terms of effectiveness and efficiency.

F25 Chassis Dynamics

6. Driving stability control systems

6.4.2. VTG control unit system wiring diagram

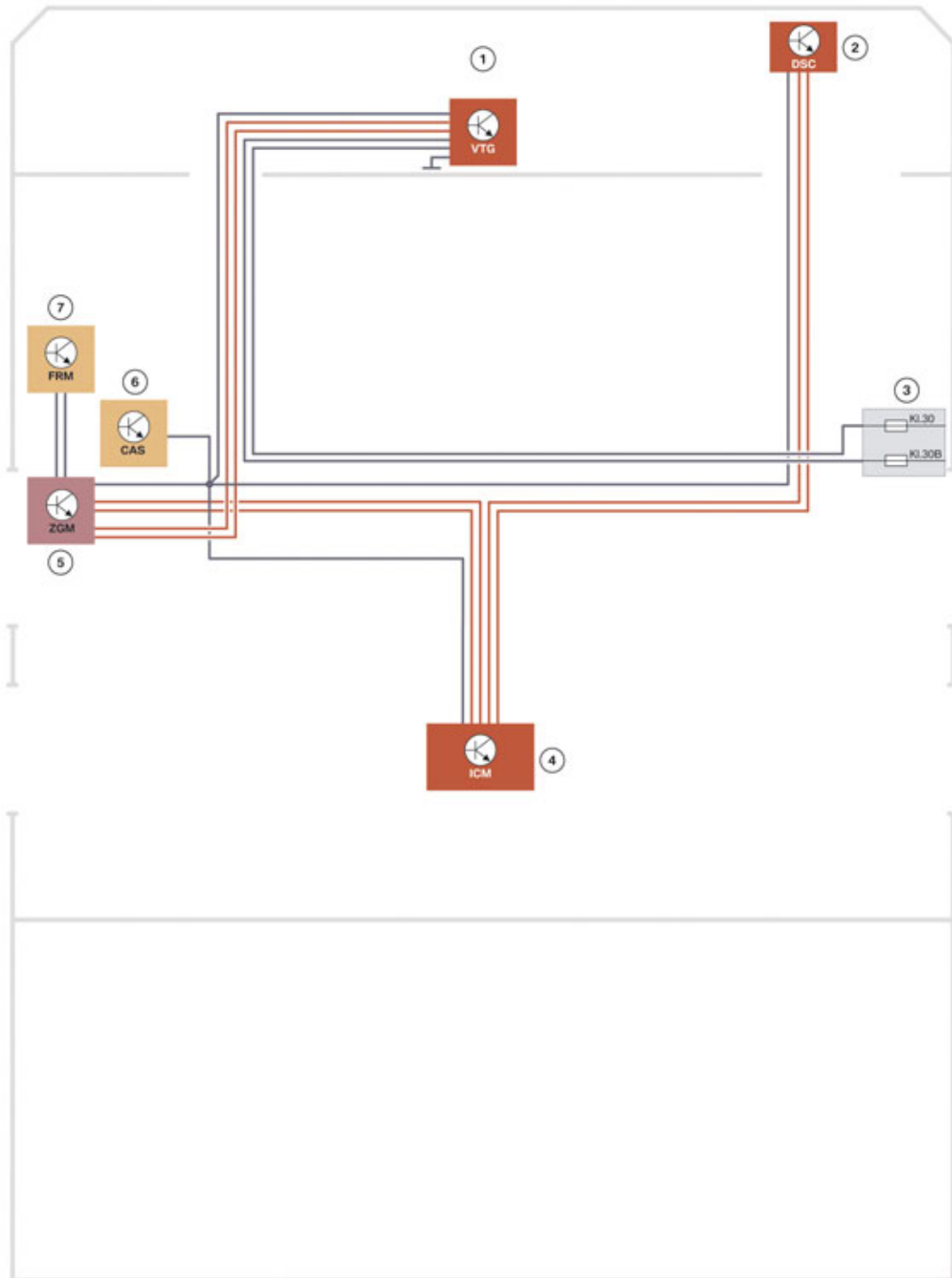

F25 VTG system wiring diagram

TF10-0806

F25 Chassis Dynamics

6. Driving stability control systems

Index	Explanation
1	VTG control unit
2	Dynamic Stability Control (DSC)
3	Junction box power distribution box
4	Integrated Chassis Management (ICM)
5	Central gateway module (ZGM)
6	Car Access System (CAS)
7	Footwell module (FRM)
KI.30	Terminal 30
KI.30B	Terminal 30, time-dependent

6.4.3. Drive function

The drive torque is distributed variably in terms of driving dynamics and traction as the situation demands through networking with the dynamic stability control DSC. Due to its optimized design, the xDrive adaptation in the F25 makes a further contribution towards enhancing the driving experience.

Understeering

xDrive shifts more drive torque to the rear axle as the understeering tendency increases. This allows the front axle to build up more traction which reduces understeering.

At the same time the Performance Control (SA 2VG) ensures, through braking intervention at the inner rear cornering wheel and by increasing the drive torque of the engine, that the vehicle adopts a neutral drivability without slowing it down.

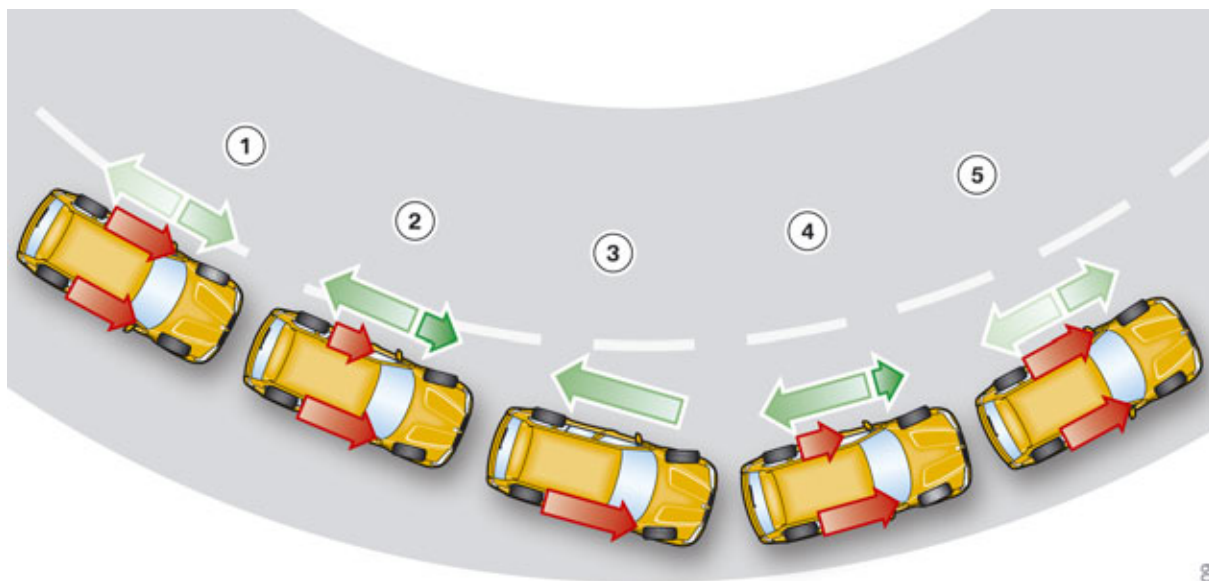

TF10-0909

F25 Chassis Dynamics

6. Driving stability control systems

Index	Explanation
red arrow	Performance Control intervention
green arrow	xDrive intervention
1	On the approach to the bend, xDrive adjusts the distribution of drive torque so the emphasis is slightly towards the rear
2 and 3	During cornering, xDrive shifts more drive torque to the rear axle; Performance Control counteracts understeering
4	As the understeering tendency reduces, more drive torque is directed to the front axle and the intervention by Performance Control diminishes
5	xDrive re-establishes the standard distribution, intervention by Performance Control is no longer required

Oversteering

In an oversteering driving situation, xDrive distributes the drive torque so that the load on the rear axle is reduced as much as possible.

At the same time, the DSC ensures, through additional brake intervention at the outer rear wheel during cornering, that the vehicle is quickly stabilized and that neutral drivability is restored.

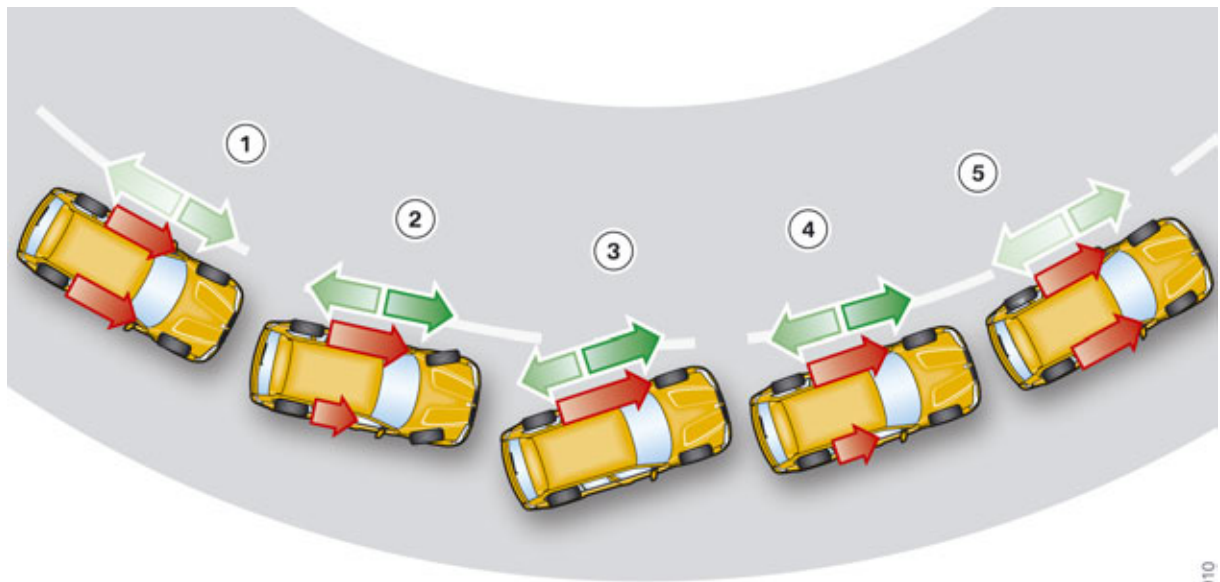

F25 xDrive, intervention in the event of oversteering

TF10-0910

F25 Chassis Dynamics

6. Driving stability control systems

Index	Explanation
red arrow	Performance Control intervention
green arrow	xDrive intervention
1	On the approach to the bend, xDrive adjusts the distribution of drive torque so the emphasis is slightly towards the rear
2	If an oversteering tendency exists, xDrive shifts more drive torque to the front axle
3	As the oversteering tendency increases, Performance Control (SA 2VG) further stabilizes the vehicle through braking intervention at the outer rear wheel during cornering
4	As the oversteering tendency reduces, less drive torque is directed to the front axle and the intervention by Performance Control diminishes
5	xDrive re-establishes the standard distribution, intervention by Performance Control is no longer required

6.5. Performance Control

The F25 features Performance Control (SA 2VG), the DSC functionality of the xDrive.

To increase the agility of the xDrive vehicle, the understeering tendency and the required steering angle are reduced. This is implemented by varying the torque distribution at the rear axle. The Performance Control brakes the rear inner cornering wheel when the vehicle is being driven with a sporty driving style. At the same time, the drive torque of the engine is increased to compensate for the braking torque produced.

Due to the driving dynamics, the Performance Control is withdrawn at high speeds.

6.6. Dynamic Cruise Control DCC

The Dynamic Cruise Control DCC is a road speed controller that incorporates brake intervention.

The DCC maintains a constant set speed at speeds higher than roughly 30 km/h - as opposed to conventional speed control with the following additional functions:

- **Active brake intervention** - if the engine drag torque is insufficient to maintain the selected speed in coasting (overrun) mode, the vehicle is decelerated automatically by means of additional controlled brake intervention.
- **Curve-Speed-Limiter CSL** - depending on the lateral acceleration that currently exists, the speed in the longitudinal direction is reduced during controlled cornering as necessary. When exiting the corner, the speed is adjusted until the required speed is obtained once again.

F25 Chassis Dynamics

6. Driving stability control systems

- **Comfort-Dynamic-System CDS** - the driver can use an operating element at the steering wheel to permanently accelerate or decelerate the vehicle in two dynamic stages respectively in "Hand throttle mode". This means the required speed will be reached more quickly. The driver can accelerate or decelerate in traffic flow without estimating the target speed beforehand.
- **Controlled downhill driving** - in order to reduce fuel consumption, downhill driving is controlled by means of overrun fuel cutoff. To reduce the load on the wheel brakes when driving downhill, gear downshifts are modified and torque is distributed between the front and rear axle. In the DSC brake control system, corresponding leakage compensation and torque distribution measures are applied using a substitute temperature model. This counteracts any leakage in the brake control circuit.

The desired speed is displayed in the instrument panel (KOMBI) by a movable marker around the speed reading. When the control system is active, this marker lights up green. When the DCC function is deactivated, the marker lights up orange and the resume speed is displayed. If the desired speed has been adjusted or if the DCC function is activated, the updated digital value is displayed briefly as a checkback signal for the operator.

F25 Chassis Dynamics

6. Driving stability control systems

6.7. Electronic Damper Control (EDC)

6.7.1. System overview

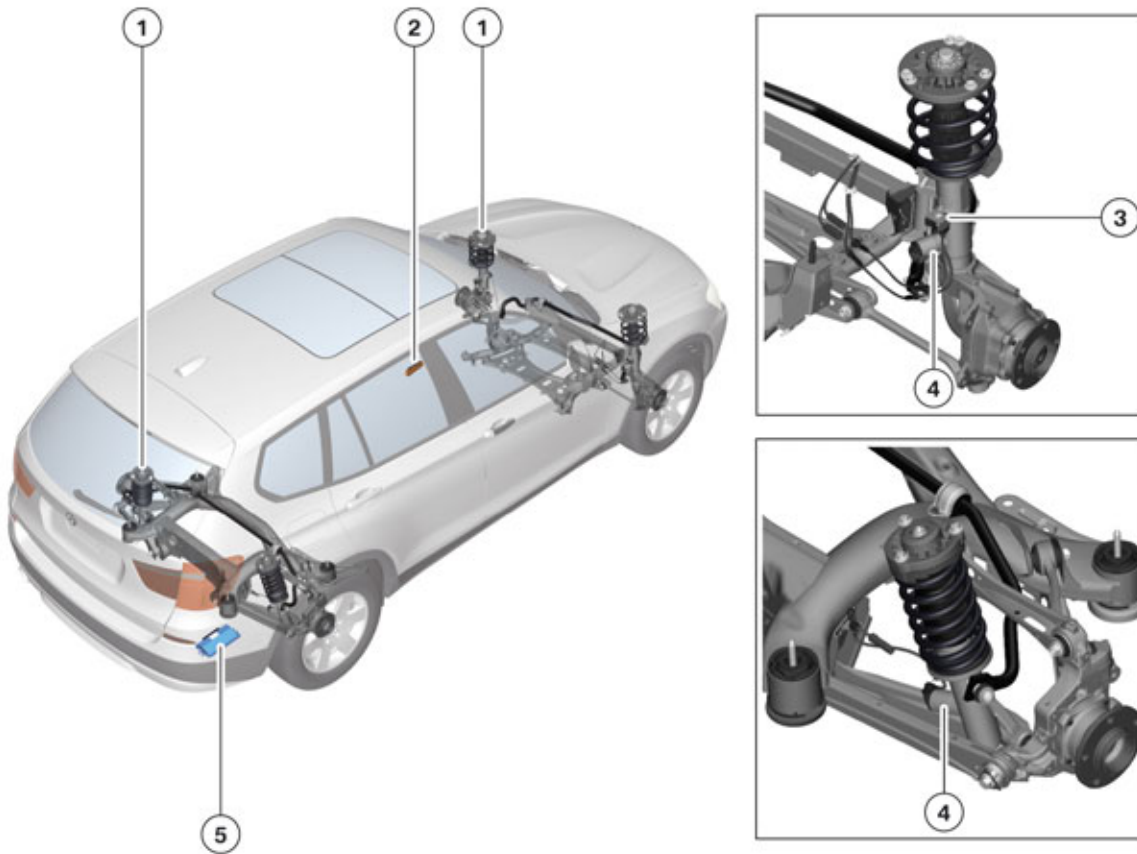

TF10-1098

F25 EDC system overview

Index	Explanation
1	Electronic adjustable damper
2	Driving dynamics control switch
3	Wheel acceleration sensor
4	Electromagnetic setting valve
5	EDC control unit

F25 Chassis Dynamics

6. Driving stability control systems

6.7.2. System wiring diagram

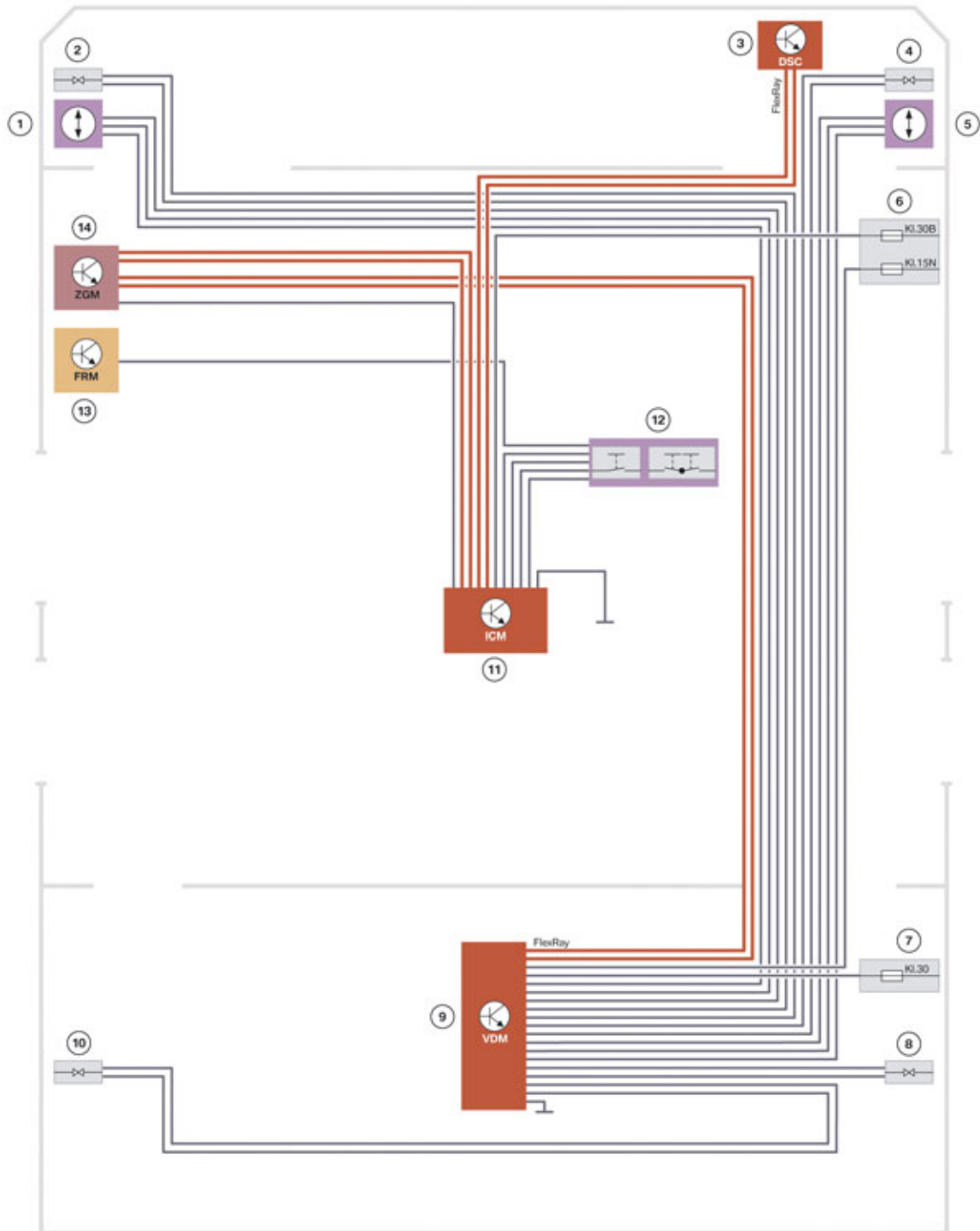

F25 EDC system wiring diagram

TF10-0609

F25 Chassis Dynamics

6. Driving stability control systems

Index	Explanation
1	Sensor, vertical wheel acceleration, front left
2	Electromagnetic setting valve, front left
3	Dynamic Stability Control (DSC)
4	Electromagnetic setting valve, front right
5	Sensor, vertical wheel acceleration, front right
6	Junction box power distribution box
7	Luggage compartment power distribution box
8	Electromagnetic setting valve, rear right
9	Vertical Dynamics Management (VDM)
10	Electromagnetic setting valve, rear left
11	Integrated Chassis Management (ICM)
12	Center console operating facility
13	Footwell module (FRM)
14	Central gateway module (ZGM)
KI.30B	Terminal 30, time-dependent
KI.15N	Ignition (after-run)
KI.30	Terminal 30

6.7.3. System function

The EDC is a variable, electronically controlled shock absorber adjustment system that controls the vertical dynamics. EDC adapts the damping forces of the shock absorber more or less instantly to changing road or driving conditions.

The EDC consists of

- four electronic adjusting dampers
- the EDC control unit
- two wheel acceleration sensors on the front axle to determine the wheel movement
- a sensor cluster integrated in the ICM control unit to determine the movements of the body (pitch, vertical, roll).

The sensors in the vehicle permanently measure

- the body and wheel acceleration
- the current lateral/longitudinal acceleration
- the vehicle speed
- the steering wheel position.

F25 Chassis Dynamics

6. Driving stability control systems

The EDC control unit uses this measured data in conjunction with the road profile and driving situation to calculate the wheel-specific control commands for the electromagnetic valves in the shock absorbers. The damping forces delivered will therefore always match the requirements.

This improves ride comfort and at the same time enhances driving dynamics.

- Increased body stability and agility
- Improved driving safety by minimizing wheel load fluctuation and reduced stopping distance.

The driver can use the driving dynamics control switch to change between a comfortable or sporty aspect of the vehicle's character according to his individual requirements.

6.7.4. Service information

Other separate lines exist between the dampers, including front axle sensors and the wiring harness. These are not shown in the system wiring diagram. These lines can be replaced individually when carrying out repairs.

6.8. Driving dynamics control switch



F25 center console

Index	Explanation
1	Driving dynamics control switch
2	Controller

The driving dynamics control switch is installed in the center console operating facility. Three areas (characteristic curves) for driving dynamics can be selected via the driving dynamics control switch: Normal, Sport, Sport+.

The Sports mode can be adapted by means of the Controller.

F25 Chassis Dynamics

6. Driving stability control systems



F25 Sports mode adaptation

It is possible to specify whether the Sports mode applies only to the chassis and suspension, only to the drivetrain, or to both.

	Normal	Sport	Sport+
Drivetrain			
Accelerator characteristic	Normal	Sports	Sports
Shift program	Normal	Sports	Sports
Shift speed	Normal	Sports	Sports
Chassis and suspension systems			
Steering servo	Normal	Sports	Sports
Dynamic Stability Control	DSC on	DSC on	DTC
Electronic Damper Control (EDC)	Normal	Sports	Sports



Bayerische Motorenwerke Aktiengesellschaft
Händlerqualifizierung und Training
Röntgenstraße 7
85716 Unterschleißheim, Germany