

Technical training.
Product information.

F25 Entertainment and Communication



BMW Service

Edited for the U.S. market by:
BMW Group University
Technical Training
ST1106 2/1/2011

General information

Symbols used

The following symbol is used in this document to facilitate better comprehension or to draw attention to very important information:



Contains important safety notes and information that needs to be observed strictly in order to guarantee the smooth operation of the system.

Information status and national-market versions

BMW Group vehicles meet the requirements of the highest safety and quality standards. Changes in requirements for environmental protection, customer benefits and design render necessary continuous development of systems and components. Consequently, there may be discrepancies between the contents of this document and the vehicles available in the training course.

This document basically relates to the European version of left hand drive vehicles. Some operating elements or components are arranged differently in right-hand drive vehicles than shown in the graphics in this document. Further differences may arise as the result of the equipment specification in specific markets or countries.

Additional sources of information

Further information on the individual topics can be found in the following:

- Owner's Handbook
- Integrated Service Technical Application.

©2010 BMW AG, Munich

Reprints of this publication or its parts require the written approval of BMW AG, München

The information contained in this document forms an integral part of the technical training provided by the BMW Group and is intended for its course trainers and participants. Refer to the latest relevant information systems of the BMW Group for any changes/additions to the Technical Data.

Status of the information: **July 2010**
VH-23/International Technical Training

F25 Entertainment and Communication

Contents

1. Introduction	1
1.1. F25 Bus overview	2
2. Radio and headunits	5
2.1. Car Information Computer, CIC	5
2.1.1. Block diagram, CIC	6
2.1.2. System wiring diagram	8
2.2. Car information computer basic, CIC Basic 2	10
2.2.1. Block diagram	11
2.2.2. System wiring diagram	12
3. Speaker systems	14
3.1. Overview	14
3.2. Components	14
3.2.1. Hi-fi system	14
3.2.2. Top HiFi system	15
4. Telephone systems	17
4.1. Overview	17
4.2. System components	17
4.3. General information	18
4.3.1. Compatibility	18
4.4. Hands-free system with USB interface	20
4.4.1. System wiring diagram	23
4.5. Combox features	24
4.5.1. System wiring diagram	25
4.5.2. Functions	26
5. Connected Drive	34
5.1. Google™ local search	34
6. Antenna systems	35
6.1. System wiring diagram	38

F25 Entertainment and Communication

1. Introduction

The information and communication system plays a significant role in the F25. It can access the highly advanced technology available from BMW which provides the driver with a wide selection of Infotainment systems.

This training material provides an overview of the following systems:

- Radio and headunits
- Speaker systems
- Telephone systems
- Connected Drive
- Antenna systems.

F25 Entertainment and Communication

1. Introduction

1.1. F25 Bus overview

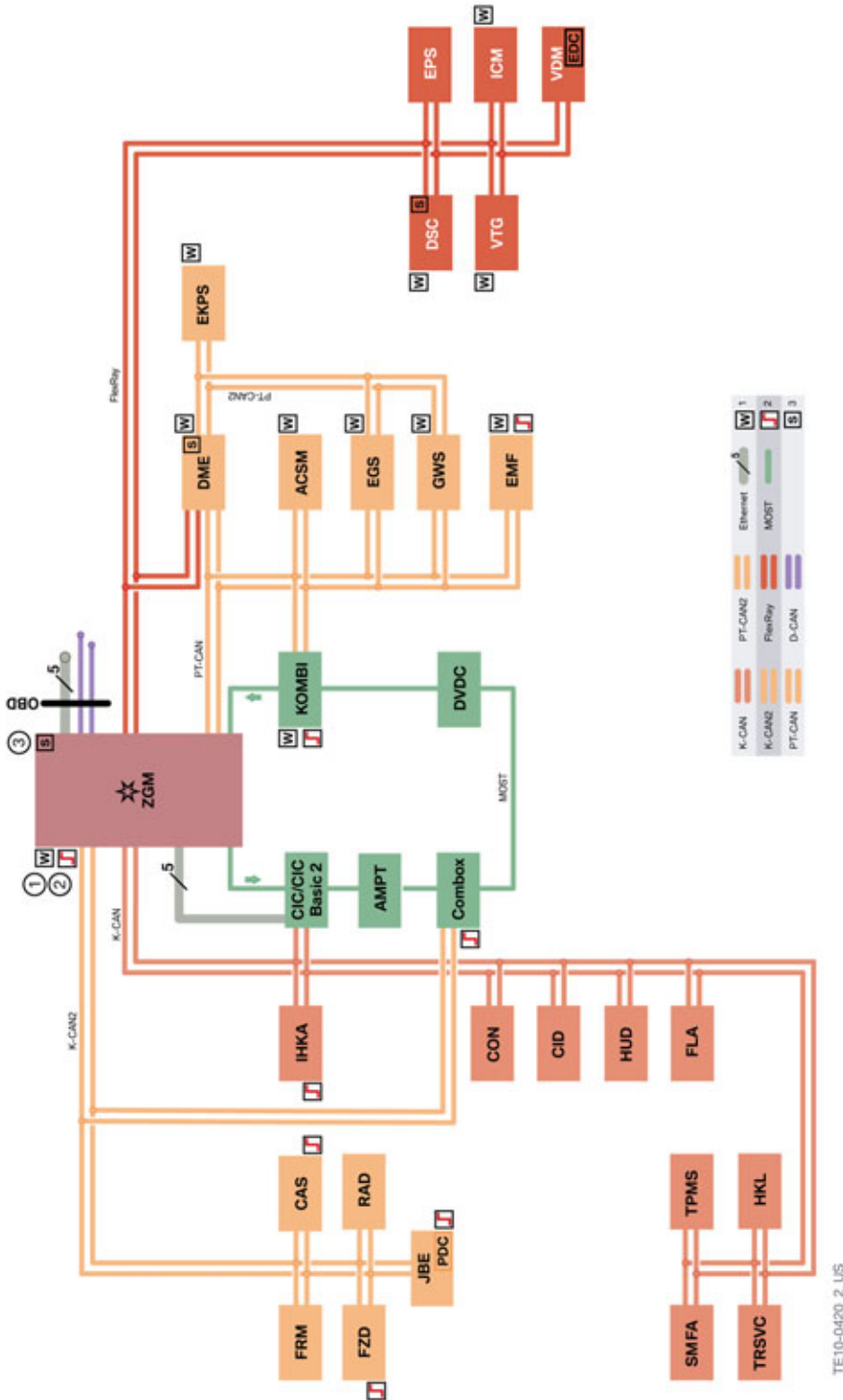

F25 Entertainment and Communication

1. Introduction

Index	Explanation
1	Wakeable control units
2	Control units with wake-up authorization
3	Start-up node control units for starting up and synchronizing the FlexRay bus system
ACSM	Advanced Crash Safety Module
AMPT	Top HiFi amplifier
CAS	Car Access System
CID	Central information display
COMBOX	Combox (Combox multimedia, Combox multimedia with telematics)
CON	Controller
D-CAN	Diagnosis-on-Controller Area Network
DME	Digital Motor Electronics
DSC	Dynamic Stability Control
DVDC	DVD changer
EDC	Electronic Damper Control
EGS	Electronic transmission control
EKPS	Electronic fuel pump control
EMF	Electromechanical parking brake
EPS	Electronic power steering (electromechanical power steering)
Ethernet	Cable-based data network technology for local data networks
FLA	High-beam assistant
FlexRay	Fast, preset and fault-tolerant bus system for use in automotive sector
FRM	Footwell module
FZD	Roof function center
GWS	Gear selector switch
HEADUNIT	Headunit (car information computer or car information computer basic II)
HKL	Automatic operation of tailgate
HUD	Head-Up Display
ICM	Integrated Chassis Management
IHKA	Automatic integrated heating and A/C control unit
JBE	Junction box electronics
K-CAN.	Body controller area network
K-CAN2	Body controller area network 2
KOMBI	Instrument panel
MOST	Media Oriented System Transport

F25 Entertainment and Communication

1. Introduction

Index	Explanation
OBD	On-board diagnosis (diagnostic socket)
PDC	Park Distance Control
PT-CAN	Powertrain controller area network
PT-CAN 2	Powertrain controller area network 2
RAD	Radio
SMFA	Driver's seat module
TPMS	Tire Pressure Monitoring System
TRSVC	Control unit for camera systems
VDM	Vertical dynamics management
VTG	Transfer box
ZGM	Central gateway module

F25 Entertainment and Communication

2. Radio and headunits

2.1. Car Information Computer, CIC

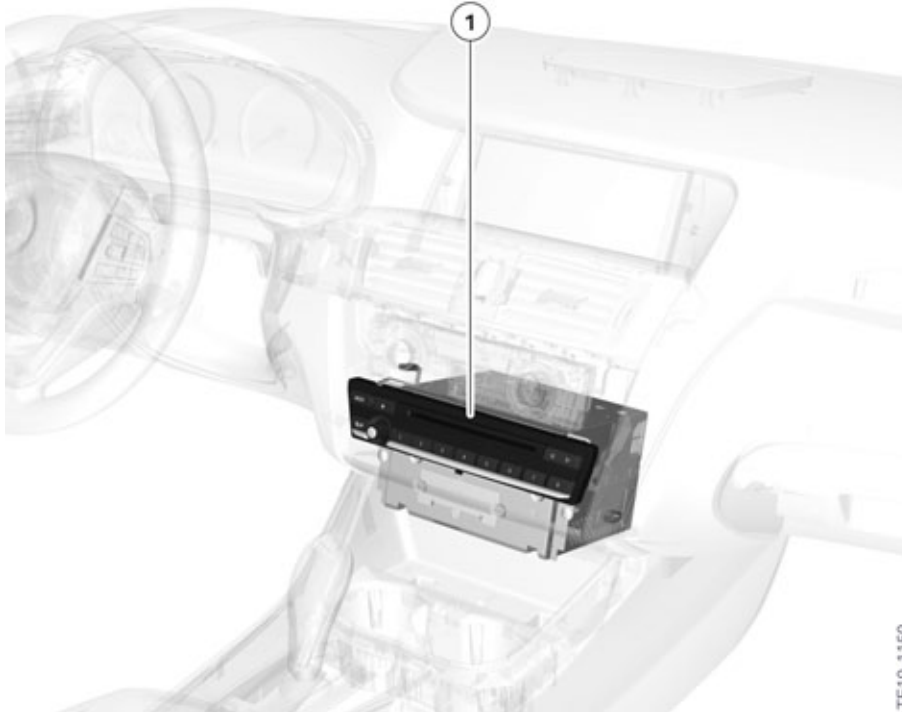

Car Information Computer

Index	Explanation
1	Car Information Computer, CIC

The CIC headunit was installed for the first time in the BMW 1-Series and 3-Series vehicles in conjunction with the Navigation system (SA 609).

A wide range of new options are now available with this headunit including an 8.8-inch high-resolution trans-reflective screen that is the largest on-board monitor in its vehicle segment.

As with the latest CIC systems a hard disk storage capacity of 80 GB is used in combination with the Navigation system option.

With regard to audio system, a 12 GB partition of the total hard drive memory is set aside for the music collection function. Music files can be converted (ripped) from CDs or copied from USB drives to the music collection on the systems hard drive. Storing these files on the CIC-dedicated hard disk, allows for fast and easy access to the customer's music at all times. A selection of up to 3700 music files can be stored with the system.

In contrast with CIC Basic 2 (which has a CD drive) CIC with Navigation incorporates a DVD drive.

CIC incorporates a double tuner for the FM/AM band, one is used for tuning the other to update the station list and station information. The FM/AM double tuner module and the FM-TMC module combine to form the triple tuner.

The digital radio tuner (IBOC) and satellite tuner (SDARS) radio systems are now integrated into the CIC, this mean there is no need to install separate control units for these functions.

F25 Entertainment and Communication

2. Radio and headunits

The Bluetooth antenna is located within the wiring harness and two microphones are installed on the headline just above the driver and passenger.

For more information on the Car Information Computer, please refer to the Owner's Manual or ST 815 Car Information Computer (CIC) training material available on TIS and ICP.

2.1.1. Block diagram, CIC

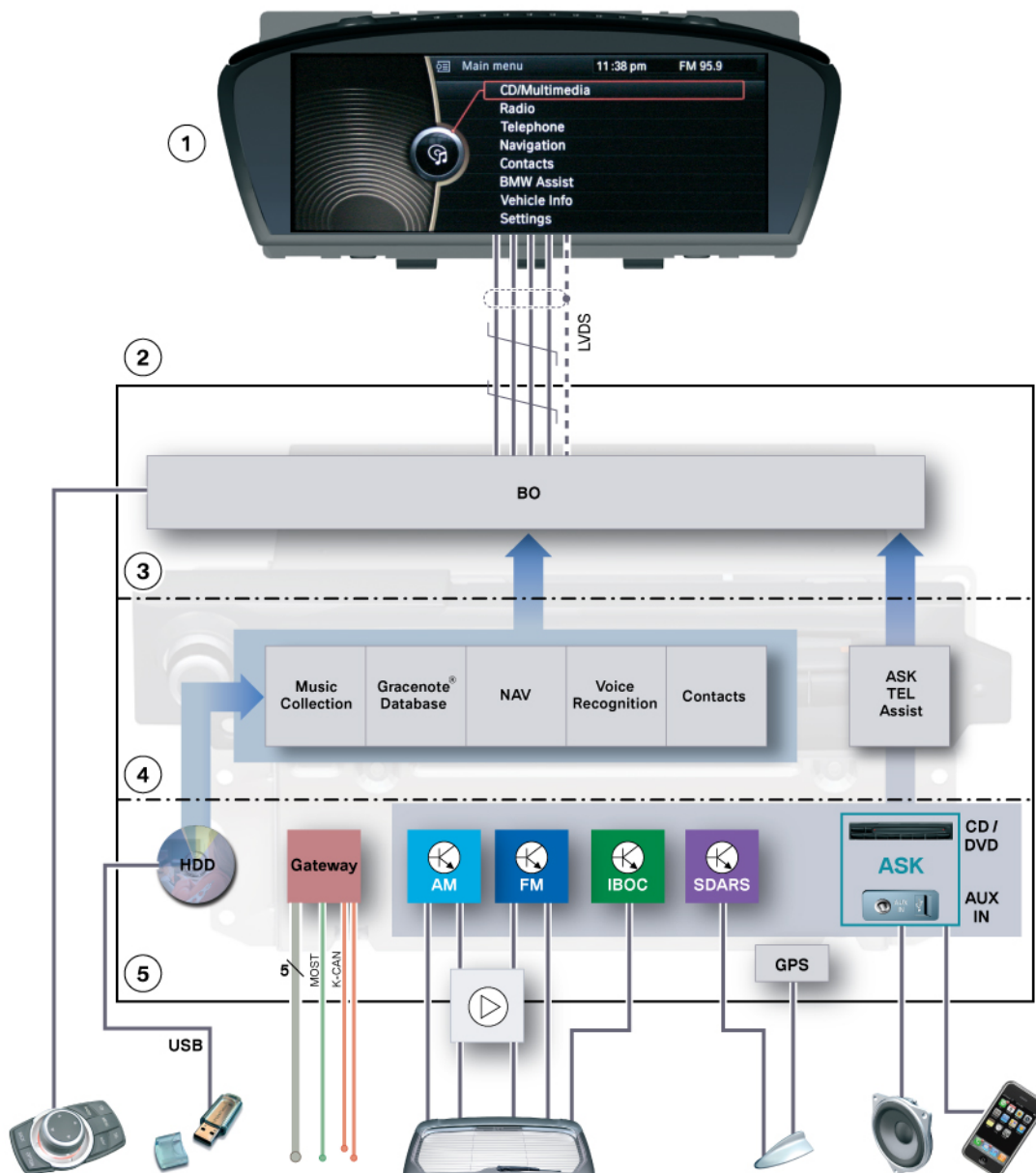

F25 Block diagram of CIC

F25 Entertainment and Communication

2. Radio and headunits

Index	Explanation
1	Central information display
2	Car Information Computer
3	User interface
4	Application software
5	Hardware and interfaces

F25 Entertainment and Communication

2. Radio and headunits

2.1.2. System wiring diagram

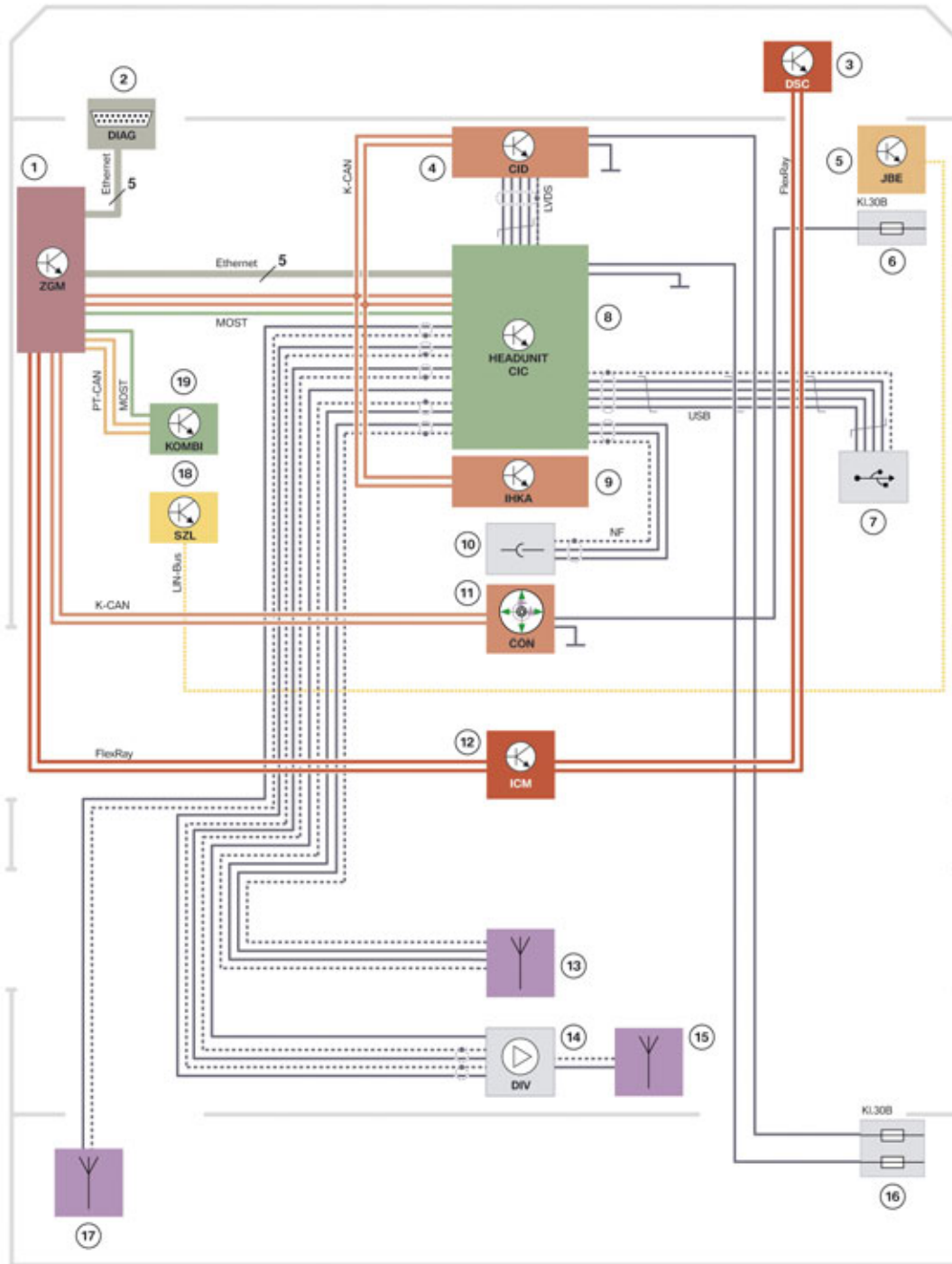

F25 CIC system wiring diagram

TE10-1153

F25 Entertainment and Communication

2. Radio and headunits

Index	Explanation
1	Central gateway module (ZGM)
2	Diagnostic interface
3	Dynamic Stability Control (DSC)
4	Central information display (CID)
5	Junction box electronics (JBE)
6	Junction box for the power distribution box
7	USB port in glove box
8	Car Information Computer
9	Automatic integrated heating and A/C control unit
10	Bluetooth antenna in wiring harness
11	Controller (CON)
12	Integrated Chassis Management (ICM)
13	Roof antenna (GPS, SDARS)
14	Antenna diversity module with integrated antenna amplifier
15	Rear window antenna (FM, AM)
16	Luggage compartment power distribution box
17	Antenna, rear left side window (DAB band 3) (not US)
18	Steering column switch cluster (SZL)
19	Instrument panel (KOMBI)

F25 Entertainment and Communication

2. Radio and headunits

2.2. Car information computer basic, CIC Basic 2

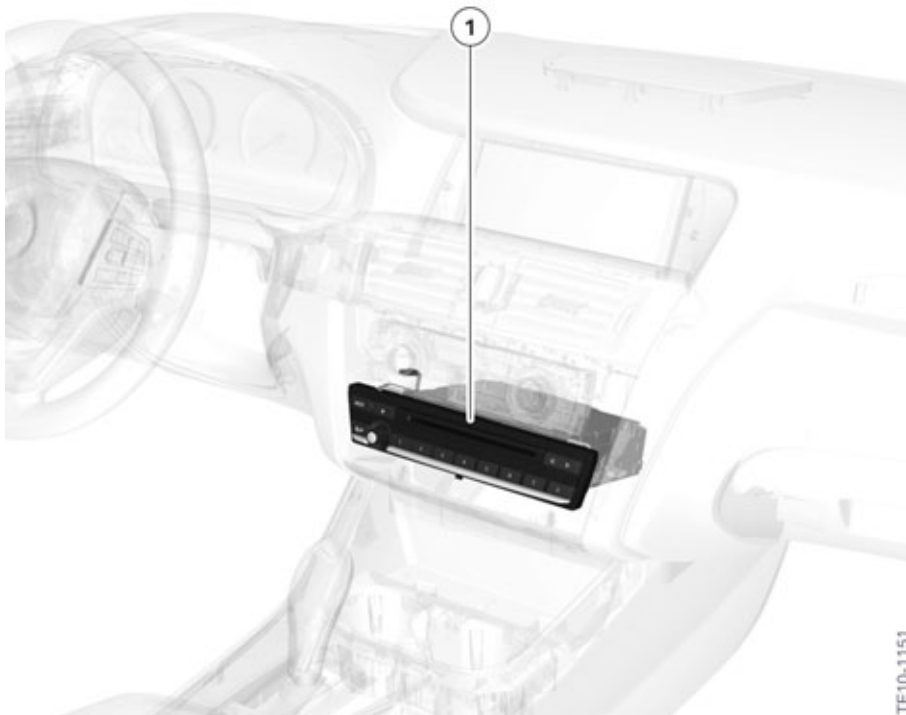

CIC Basic 2

Index	Explanation
1	Car information computer basic 2 (CIC Basic 2)

The car information computer basic 2 CIC Basic 2 (also referred to as "Champ 2") is used in the F25. The Radio Professional (SA 663) without navigation system is standard on both variants of the F25.

In contrast to its predecessors (M-ASK and CHAMP), the CIC Basic 2 is not equipped with a DVD drive. Only a single CD drive is installed in the headunit which means that the CIC Basic 2 only supports playback of audio files and not DVDs.

The contacts are now located in a flash memory in the form of an SD memory card with a 2GB capacity. In the F25, this system is installed in combination with the standard radio without navigation.

Furthermore, the IBOC and SDARS digital tuners hardware and software functions have been incorporated into the CIC Basic 2 electronics and thus the range of functions substantially extended.

The CIC Basic 2 in the F25 can now be ordered for the first time with a built-in hands-free Bluetooth system due to the incorporation of the Bluetooth hardware and function into the headunit.

The CIC Basic 2 option comes with a CID Central Information Display with 6.5" screen.



Note: The CIC Basic 2 components are not replaceable separately by the BMW Service Department, if defective, it has to be replaced as a complete unit.

F25 Entertainment and Communication

2. Radio and headunits

2.2.1. Block diagram

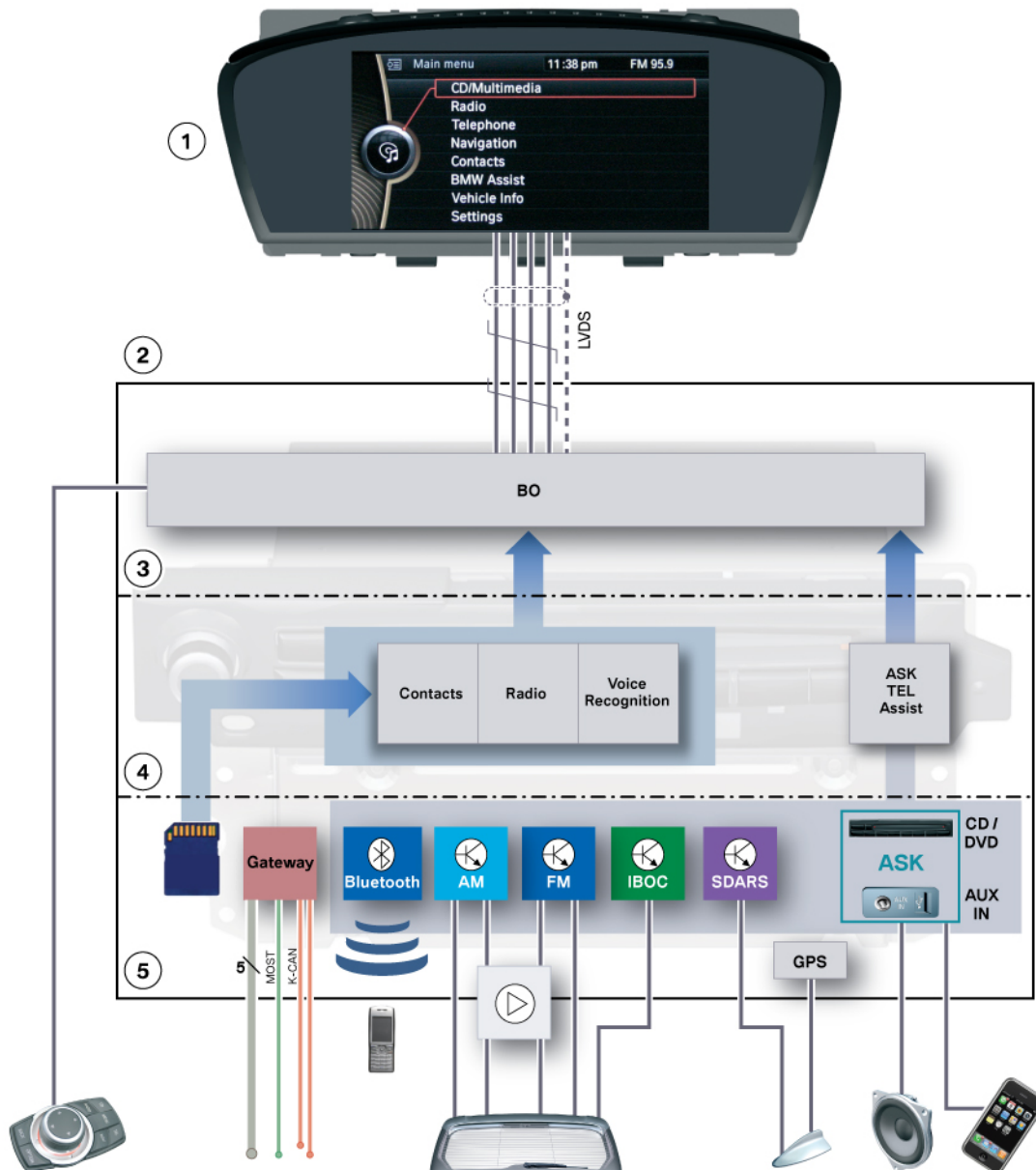

F25 Block diagram of CIC Basic 2

Index	Explanation
1	Central information display
2	Car information computer basic 2
3	User interface
4	Application software
5	Hardware and interfaces

F25 Entertainment and Communication

2. Radio and headunits

2.2.2. System wiring diagram

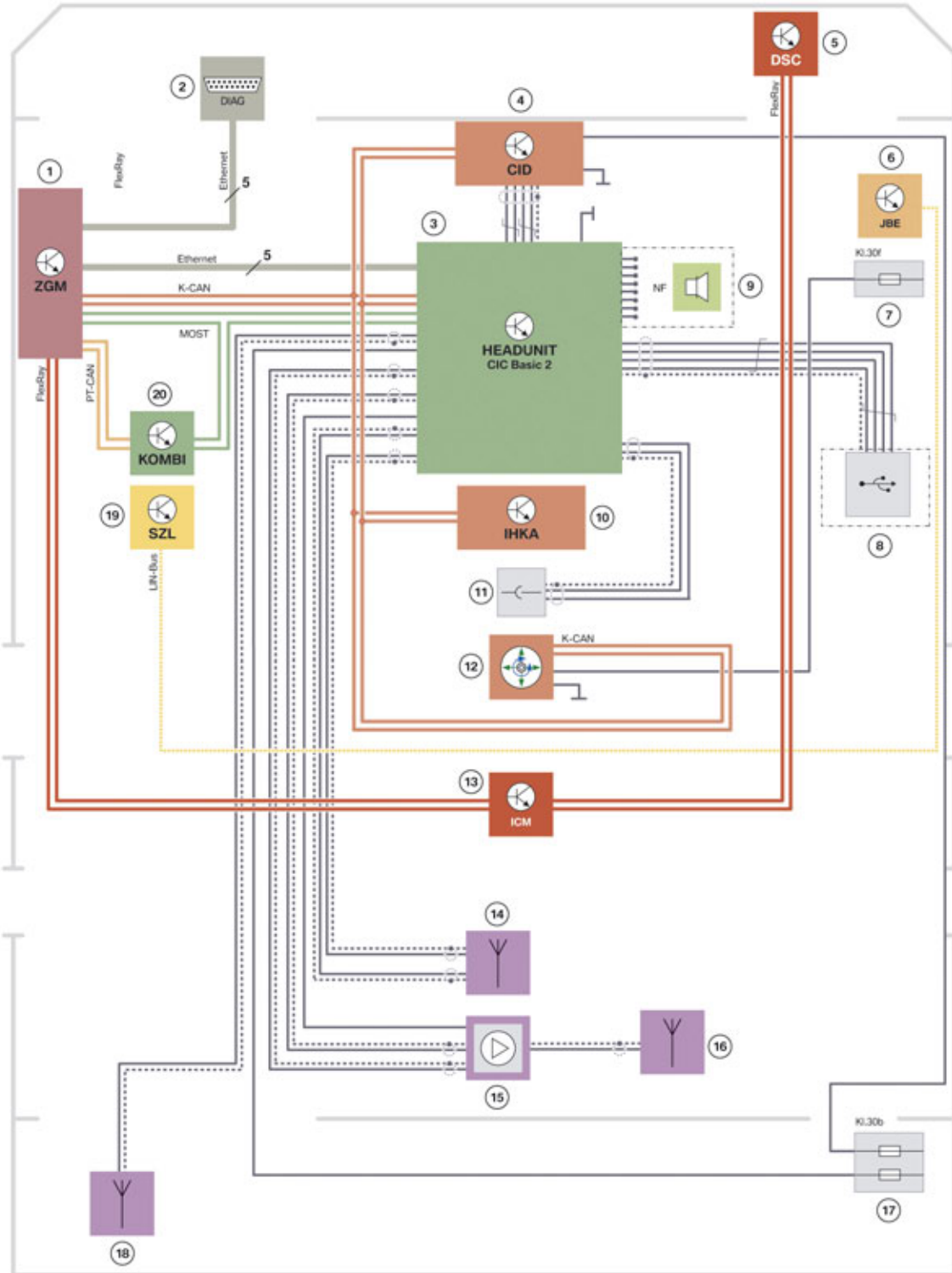

TE10-1154

F25 System wiring diagram of CIC Basic 2

F25 Entertainment and Communication

2. Radio and headunits

Index	Explanation
1	Central gateway module (ZGM)
2	Diagnostic interface
3	Car information computer basic 2 (CIC Basic 2)
4	Central information display (CID)
5	Dynamic Stability Control (DSC)
6	Junction box electronics (JBE)
7	Junction box for the power distribution box
8	USB port ¹
9	AF output, vehicle speaker (stereo system)
10	Automatic integrated heating and A/C control unit
11	Bluetooth antenna in wiring harness
12	Controller (CON)
13	Integrated Chassis Management (ICM)
14	Roof antenna (GPS, SDARS)
15	Antenna diversity module with integrated antenna amplifier
16	Rear window antenna (FM and AM)
17	Luggage compartment power distribution box
18	antenna, rear left side window (DAB band 3) (not US)
19	Steering column switch cluster (SZL)
20	Instrument panel (KOMBI)

¹ The USB interface is installed in the center console in vehicles featuring the hands-free system with USB interface (SA 6NH).

F25 Entertainment and Communication

3. Speaker systems

3.1. Overview



F25 Speaker

The speaker systems on the F25 are available in two variants:

- Hi-fi sound system (SA 676) is standard.
- Top (Premium) HiFi System (SA 677) is optional .

A seven-channel amplifier with digital equalizing is integrated in the hi-fi system. The amplifier of the hi-fi sound system has no bus connection and receives the switch-on signal instead via a separate line.

The bass speakers are under the front seats. They are coupled to the side sills. That increases the resonance volume necessary for bass reproduction.

The CIC and CIC Basic 2 headunits can be combined with all amplifier/audio speaker systems.

The hi-fi and Top HiFi systems feature separate speakers for the treble and mid-tone ranges.

Although the diameters of the speakers in the hi-fi sound system and Top HiFi system are the same, the performance of the speakers is different. This is achieved by using different materials for diaphragms, coils and magnets.

The Top HiFi system supports playback of multichannel formats. Multichannel audio formats can be played back via the CIC drive or DVD changer for six DVDs. The amplifier of the Top HiFi system has no data bus connection and instead receives the switch-on signal via a separate line.

3.2. Components

3.2.1. Hi-fi system

The graphic below shows the hi-fi system speakers and amplifier. The speakers are operated with a power output of 5 x 25 watts for the mid-range speakers and tweeters and 2 x 40 watts for the bass speakers.

F25 Entertainment and Communication

3. Speaker systems

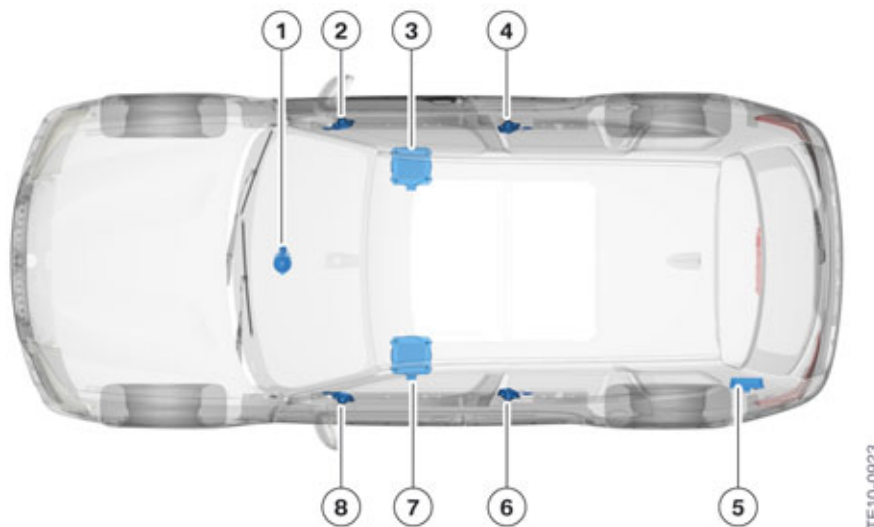

F25 Hi-fi system

Index	Explanation
1	Front center tweeter and mid-range speaker
2	Tweeter and mid-range speaker, front door on right
3	Bass speaker, under right front seat
4	Tweeter and mid-range speaker, rear door on right
5	Hi-fi amplifier
6	Tweeter and mid-range speaker, rear door on left
7	Bass speaker, under left front seat
8	Tweeter and mid-range speaker, front door on left

3.2.2. Top HiFi system

The graphic below shows the Top HiFi system speakers and amplifier. The speakers are operated with a power output of 7 x 50 watts for the mid-range speakers and tweeters and 2 x 125 watts for the bass speakers.

The amplifier of the Top HiFi system in the F25 features what is referred to as load-logic separation. In this case power is supplied to the amplifier's electronics separately by a line which is connected separately. This is specially protected against brief voltage dips which in turn prevents failure of the electronics if a voltage dip occurs briefly.

F25 Entertainment and Communication

3. Speaker systems

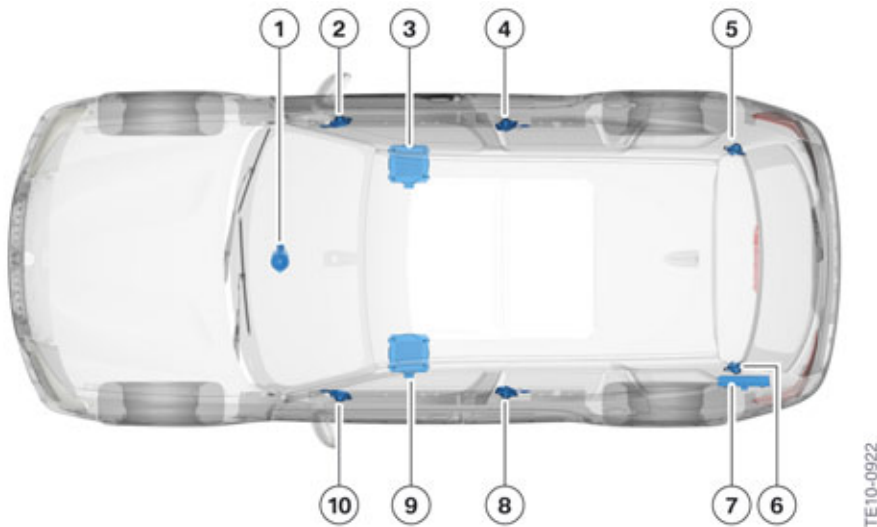

F25 Top HiFi system

Index	Explanation
1	Front center tweeter and mid-range speaker
2	Tweeter and mid-range speaker, front door on right
3	Bass speaker, under right front seat
4	Tweeter and mid-range speaker, rear door on right
5	Tweeter and mid-range speaker, D-pillar on right
6	Tweeter and mid-range speaker, D-pillar on left
7	Top HiFi amplifier
8	Tweeter and mid-range speaker, rear door on left
9	Bass speaker, under left front seat
10	Tweeter and mid-range speaker, front door on left

F25 Entertainment and Communication

4. Telephone systems

4.1. Overview



F25 Telephone system

Two different options are available for the F25 telephone systems:

- Hands-free Bluetooth and USB (SA 6NH) is standard
- BMW Assist w/enhanced Bluetooth & USB interface (SA 6NL) is available as an option

4.2. System components

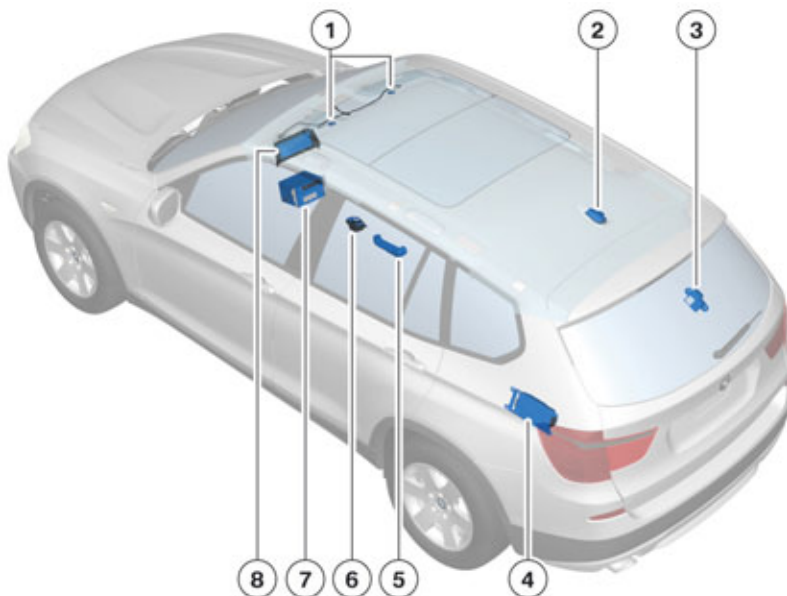

System components, telephony

F25 Entertainment and Communication

4. Telephone systems

Index	Explanation
1	Microphones
2	Roof antenna
3	Emergency call antenna
4	Combox (SA 6NL)
5	Base plate (SA 6NL)
6	Controller
7	Headunit
8	Central information display

The Bluetooth antenna is located in the audio wiring harness of the F25.

4.3. General information

The telephone functions in the F25 are provided either by the headunit or the Combox. The table below provides an overview

Equipment options	Telephone supported headunit	Combox	Only in conjunction with
Hands-free Bluetooth and USB (SA 6NH)	Yes	No	Standard equipment with BMW Radio Professional
BMW Assist w/enhanced Bluetooth & USB interface (SA 6NL)	No	Combox multimedia with integrated telematics	Optional equipment with Navigation System (SA 609)

4.3.1. Compatibility

The range and diversity of cell phones available on the market is steadily increasing. Not every Bluetooth-enabled cell phone is automatically compatible with every hands-free system. To provide the customer with a simpler, easy-to-understand overview of the currently “tested” devices, the website at <http://www.bmwusa.com/bluetooth> is being constantly updated. Customers are able to use the website to determine which devices and functions work and which do not with their specific BMW model.

The customer can now obtain information regarding the compatibility of specific tested cell phones with their vehicles (by entering the vehicle VIN number for example). A prospective BMW customer can also find out which cell phones have been tested and are compatible with specific BMW models.

F25 Entertainment and Communication

4. Telephone systems

Home 1 3 5 6 7 X3 X5 X6 Z4 M All BMWs Certified Pre-Owned Owners Experience Uniquely BMW

Build Your Own Dealer Locator Test Drive Financial Services Accessories My BMW Search

BMW USA The Ultimate Driving Machine

Owners

- Overview
- BMW Ultimate Service®
- BMW Ultimate Protection
- Maintenance Program Upgrade
- BMW Assist™
- BMW Roadside Assistance
- Drive
- Real Time Traffic Information
- Exceptional Value
- Residual Value
- Safety
- Traction
- Performance
- xDrive
- Owner's Manuals
- BMW Center Services
- Certified Collision Repair Centers
- Bluetooth Technology
- Connecting a Music Player

Bluetooth Compatibility

- Overview
- Bluetooth Benefits
- Currently Available Phones
- FAQ

3. Tested mobile phones.

Vehicle selected: 7 Series Sedan LI Model Year 2011

13 devices

Narrow down your choice:

- Reset selection
- Wireless carrier: at&t
- Select manufacturer: All manufacturers
- Which functions do you mainly wish to use?
 - Handsfree
Hands-free kit.
 - Phone book
Access to your contacts.
 - Office
Manage email, calendar and notes.
 - Audio playback via Bluetooth
Import and listen to music and playlists.

Apple iPhone 4, Apple iPhone™ 3G, Apple iPhone™ 3GS, Palm Treo PRO GSM/UMTS Unlocked, RIM/BlackBerry Pearl 3G™ 9100, RIM/BlackBerry 9820, RIM/BlackBerry Bold™ 9000, RIM/BlackBerry Bold™ 9700, RIM/BlackBerry Curve™ 8320, RIM/BlackBerry Javelin™ 8900, SonyEricsson W350a, SonyEricsson W518a, SonyEricsson W760a

BMWusa.com/bluetooth Internet page under "Currently available phones"

The following information is available:

- The tested phones are organized based on BMW model and wireless carrier
- Detailed information regarding individual functions is organized based on phone manufacture and on which functions the specific phone can perform.
- Information about how to improve cell phone to vehicle compatibility by means of a downloadable Bluetooth profile software updates will be available later in 2011)

F25 Entertainment and Communication

4. Telephone systems

At first, only phones will be included in the device database, they will be followed by audio players and other devices that can be connected with the Combox via Bluetooth.

4.4. Hands-free system with USB interface

The headunit with built in Bluetooth telephone is featured for the first time in the F25 in conjunction with the CIC Basic 2. With this system, no additional control unit is required in order to provide Bluetooth telephone functions in the vehicle. With the standard equipment Hands free Bluetooth and USB (SA 6NH), the customer is provided with a USB audio interface in addition to the telephone function.



F25 Telephone menu in CID

Index	Explanation
1	"Phone book"
2	"Re-dialling"
3	"Incoming telephone calls"
4	"Dial number"
5	"Bluetooth (telephone)"

F25 Entertainment and Communication

4. Telephone systems



F25 Bluetooth pairing

Index	Explanation
1	"Add new device"
2	"Connected:"
3	"Logged on:"

F25 Entertainment and Communication

4. Telephone systems

The phone book and lists of callers are transferred from the cell phone. Contacts can be stored in the address memory of the headunit in addition to the phone's phone book. The address memory is used by the navigation system as well as the telephone system.

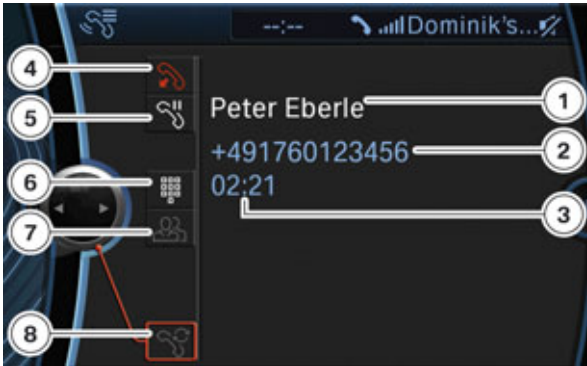

F25 Call options

Index	Explanation
1	Name of party
2	Phone number of party
3	Call duration
4	End call
5	Hold call
6	Activate DTMF (Dual Tone Multiplexed Frequency) sound generation (*)
7	Conference call
8	Toggle calls

(*) During the call the telephone supported headunit allows calls to be held or extended (conference call) and also DTMF tones to be transmitted. So for example, if you call a phone number and then the operator tells you to select "1" for English, by pressing the number 1 on your keypad, you are sending a DTMF tone.

Analogue devices, USB sticks and MP3 players can be connected to the USB interface in the center console.

F25 Entertainment and Communication

4. Telephone systems

4.4.1. System wiring diagram

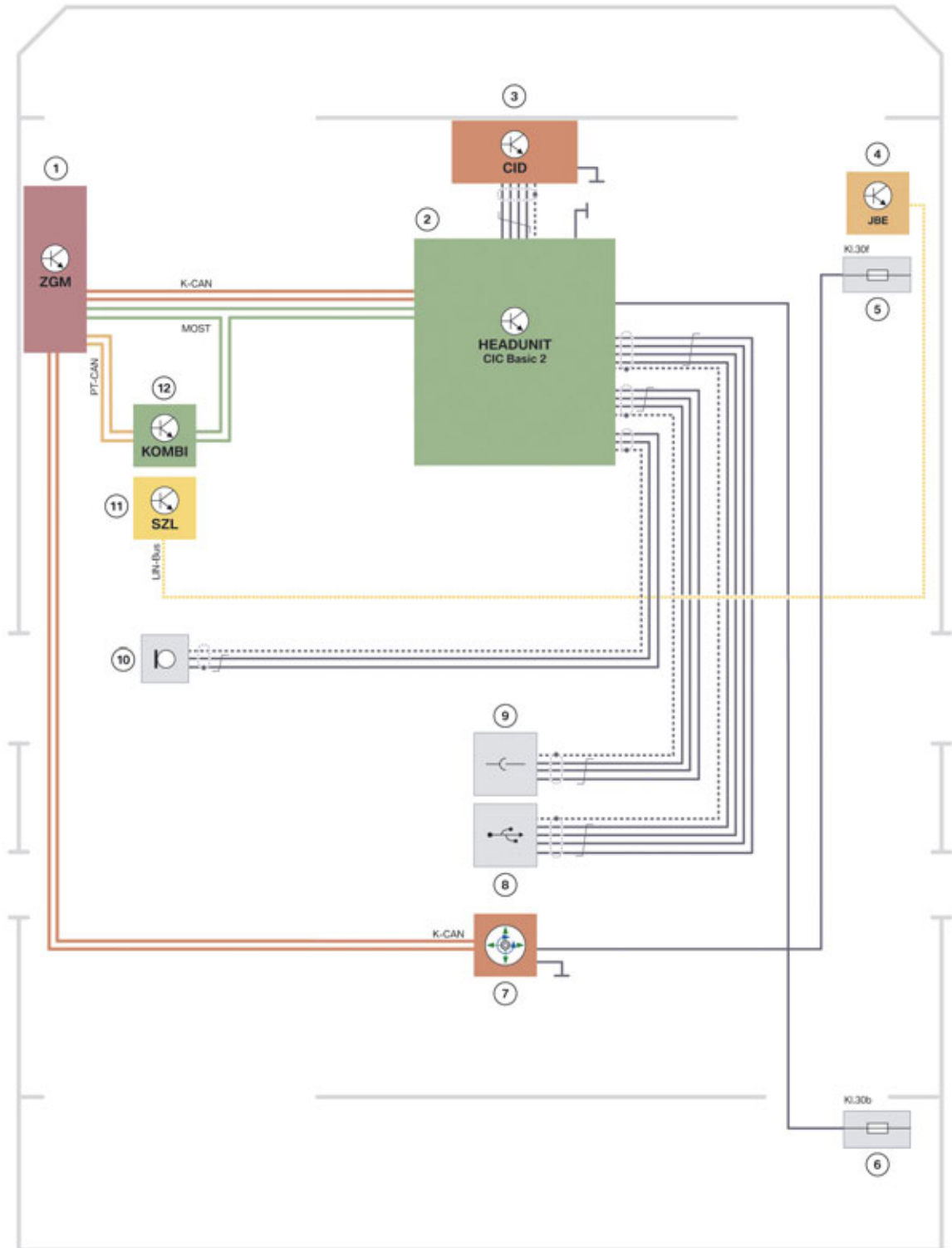

TE10-0743

F25 System wiring diagram SA 6NH

F25 Entertainment and Communication

4. Telephone systems

Index	Explanation
1	Central gateway module (ZGM)
2	Headunit (CIC Basic 2)
3	Central information display (CID)
4	Junction box electronics (JBE)
5	Junction box for the power distribution box
6	Rear power distribution box
7	Controller (CON)
8	USB port
9	Bluetooth antenna in wiring harness
10	Microphone
11	Steering column switch cluster (SZL)
12	Instrument panel (KOMBI)

4.5. Combox features

Vehicles with BMW Assist option are equipped with a Combox multimedia with telematics board (SA 6NL) and USB audio interface in conjunction with the optional equipment cell phone preparation with connection for Bluetooth and USB devices.

SA 6NL BMW Assist w/enhanced Bluetooth & USB is only available with Navigation system.



Note: Navigation system SA609 will add 6UH Real Time Traffic Information, 615 Online Information Services and 6NL BMW Assist including Mobile Office and Bluetooth audio functionality.

The following functions are available in the F25 with the Combox:

- Connection of audio players via Bluetooth
- Simultaneous pairing of several cell phones and audio devices via Bluetooth
- Contacts with images
- Software updates of the Combox by customer directly (Not yet available)
- Connection of specific iPods and iPhones via the Apple cable (Y-cable discontinued)
- Display of album cover art (with iPhone/iPod/MTP player/MP3 player via USB)
- Office function displays email, SMS, calendar, tasks, notes and reminders from cell phone via Bluetooth.

F25 Entertainment and Communication

4. Telephone systems

4.5.1. System wiring diagram

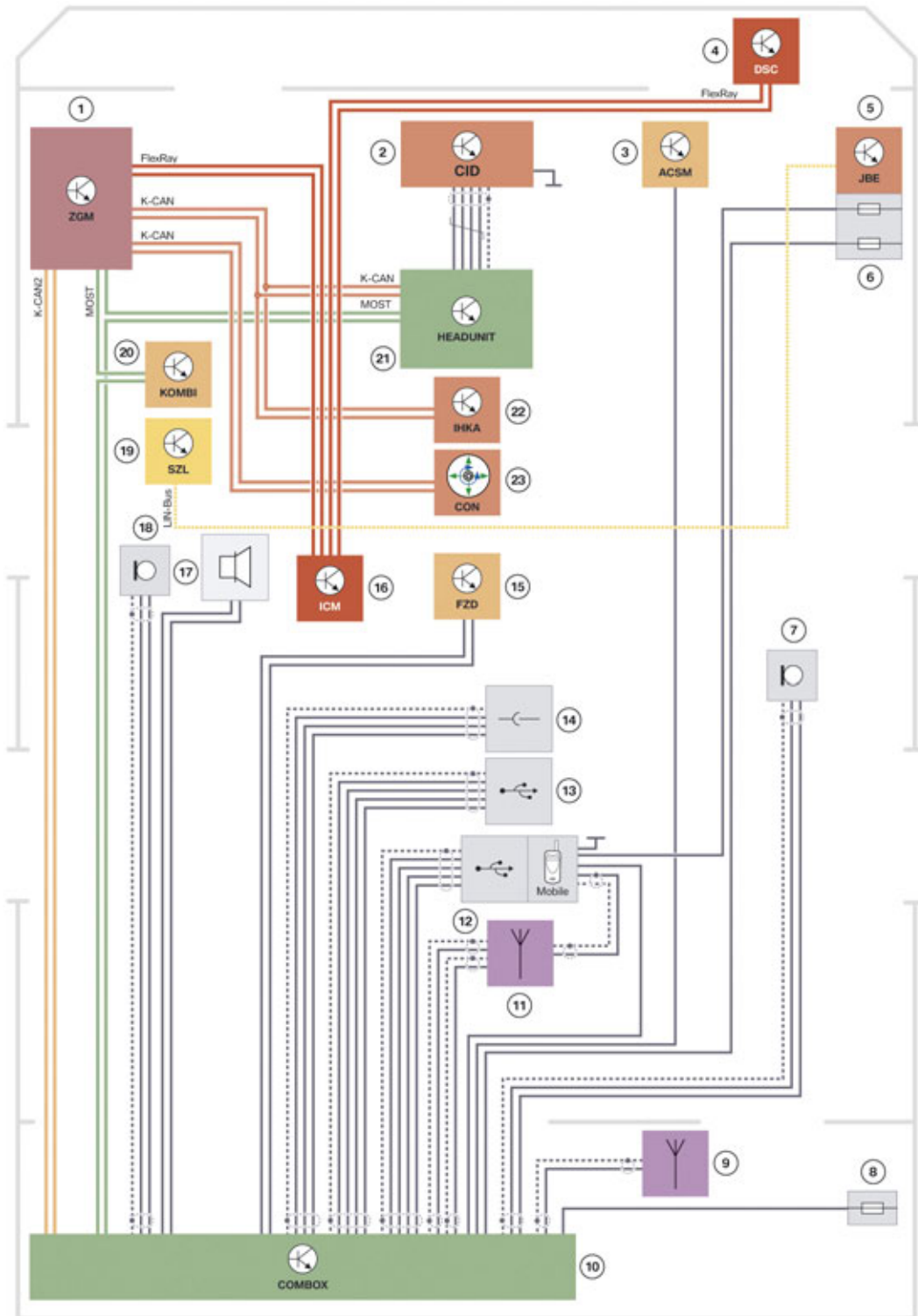

F25 System wiring diagram of CIC with Combox (6NL)

TE10-0744

F25 Entertainment and Communication

4. Telephone systems

Index	Explanation
1	Central gateway module (ZGM)
2	Central information display (CID)
3	Crash Safety Module (ACSM)
4	Dynamic Stability Control (DSC)
5	Junction box electronics (JBE)
6	Junction box for the power distribution box
7	Microphone 2
8	Luggage compartment power distribution box
9	Emergency GSM antenna (SA 6NL only)
10	Combox
11	Roof antenna
12	Base plate (only with SA 6NF)
13	USB audio interface
14	Bluetooth antenna in wiring harness
15	Emergency call button in roof function center FZD (SA 6NL only)
16	Integrated Chassis Management (ICM)
17	Emergency call speaker (SA 6NL only)
18	Microphone 1
19	Steering column switch cluster (SZL)
20	Instrument panel (KOMBI)
21	Headunit (CIC)
22	Automatic integrated heating and A/C control unit (IHKA)
23	Controller (CON)

4.5.2. Functions

Audio device via Bluetooth

The Combox in the F25 allows stereo audio signals to be transmitted wirelessly via Bluetooth from a suitable audio source. To do this, the audio source must support A2DP (Advanced Audio Distribution Profile). An audio source can be a cell phone or an MP3 player, for example. The A2DP profile is used for transmission of the audio playback signal.

The AVRCP (Audio Video Remote Control Profile) is used to control the source remotely. The range of remote control functions depends on the version of AVRCP supported by the source. The Combox supports AVRCP versions 1.0 and 1.3. Version 1.4 of AVRCP is scheduled to be released in 03/2011.

For best results and to ensure optimum functionality of audio playback via Bluetooth, you should only use BMW tested devices. These devices are listed on the Internet page <http://www.bmwusa.com/bluetooth>

F25 Entertainment and Communication

4. Telephone systems

Multiple Bluetooth pairing

With the Combox two devices can be connected simultaneously via Bluetooth. That means the audio player of one device and the telephone function of another can be connected to the vehicle simultaneously.

The configured function for each device in use is clearly shown by a phone or musical note symbol after the name of each device on the "Add new device" screen.

When two phones are connected at the same time, one will have full Office functionality (indicated by the phone/phone book icon) and the other can be used just for incoming (personal) calls as an "Additional Telephone".

This second or "Additional Telephone" will not display the contacts nor any other Office function.

This is achieved by highlighting the device and selecting "Additional Telephone" under "Configure Phone" feature in the options menu.



Configuring an additional telephone

In addition, one of these phone can also be configured to do audio streaming via Bluetooth.

The user also has the capability to select "Swap Telephone" and the devices will switch positions and functionality



Pairing of audio device or cell phone

F25 Entertainment and Communication

4. Telephone systems

Contacts with images

The Combox in the F25 supports contacts with images. These are transmitted from a compatible cell phone via Bluetooth and stored provisionally on the Combox.

Contacts can be created and edited. The contacts in the cell phone are also displayed providing the device supports this function. The addresses can be used as navigation system destinations and the phone numbers can be dialed.



Images in address book

When a person in the address book is called, the image appears in the central information display.



Calling a person in the address book with image

If another person calls when a telephone call is already in progress, a list of callers together with images is shown on the central information display.



Several callers from the address book with image



Note: This feature is not currently supported by all phones. For a detailed list of BMW tested phones and their features, please visit <http://www.bmwusa.com/bluetooth>

F25 Entertainment and Communication

4. Telephone systems

Office function



Office functions are displayed on the Office sub-menu.

The customer can use the Office function of the Combox to access the emails, SMS, calendar, notes, tasks and reminders. these functions are phone dependent and are only available with a compatible "Tested" cell phone.

The "Office" menu item replaces the "Contacts" item in the central information display regardless if the phone supports this function.

The cell phone supported Office functions will be displayed in the Office sub-menu (some phones will only display "Contacts" here).

Although access to the cell phone is always read-only and the Combox does not modify existing data on the phone, once you open a message/email via the iDrive, the status of the message on the phone will change to "read".

The user must manually change the message status on the phone in order for the message to be displayed on the iDrive next time the data is updated (e.g. key is cycled).

The "Current Office" screen tells the user about the number of new messages, which tasks are active and forthcoming deadlines.

F25 Entertainment and Communication

4. Telephone systems



Current Office sub-menu screen.

The phone calendar can display deadlines and appointments of the last 30 days and for the next 90 days.

If an appointment contains phone numbers or email addresses, they can be used directly or saved to the Contacts.



Appointment view

SMS, emails, appointment entries, tasks, reminders and notes can be read out.



Note: The Office feature is not currently supported by all cell phones. For a detailed list of BMW tested phones and their features, please visit <http://www.bmwusa.com/bluetooth>.

F25 Entertainment and Communication

4. Telephone systems

USB audio interface



Apple devices can now be connected with the original Apple USB cable.

With the Combox, an iPhone or iPod can now be connected using the customer's "original" Apple USB cable. This feature still requires the optional equipment iPod and USB adapter SA 6FL (included in option SA 6NL BMW Assist w/enhanced BT & USB) . In this case all data and other information, including the audio data, are transmitted via the USB cable. Because the device is now also charged via this cable the familiar Y cable is no longer needed.



Note: Non-compatible iPods (e.g. first-generation iPod Nanos) still have to be connected using the familiar Y cable.



Note: In some cases where the device is not sufficiently charged by the vehicle, the use of a charging adapter # 61 12 2 167 663 may be necessary. Refer to parts Bulletin # V-13-1010-6515 for more information.

Album covers

Album covers can be displayed with MP3 players, USB sticks, MTP players, iPods and iPhones providing it is included in the MP3 file.

The album covers are only displayed if the connection has been established via USB (SA 6FL).

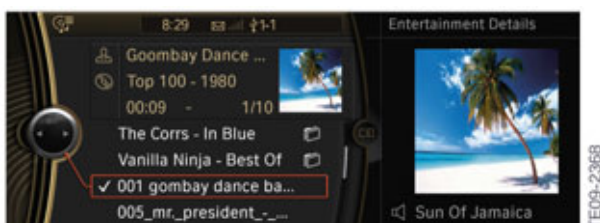

Album cover

F25 Entertainment and Communication

4. Telephone systems

The album covers are not displayed when using an iPod or iPhone with the Y-cable in this case the “original” Apple USB cable should be used.

Software updates

The Combox will enable the customer for the first time to update the firmware of a system device. To update the Combox firmware, the Bluetooth profile software update must be downloaded from the BMW web site (when one is available) and stored on a USB stick. For this purpose, any conventional USB stick with sufficient storage capacity can be used. The firmware file is then transferred from the USB stick to the Combox via the USB audio interface (option SA 6FL) in the center console.



Note: This Combox feature was still under development at the time of this training material release please refer to the BMW website <http://www.bmwusa.com/bluetooth> for more information.



Customers will be able to update the COMBOX firmware (KISU) with the Settings sub-menu “Software update”.

The customer can purchase a USB stick in the form of a BMW flat key from a BMW Service Center. This means the Service Advisor/Parts Sales Consultant can perform a one-off software update for the customer. The customer can use the USB stick to perform further software updates himself or, depending on which products are available, do this at the dealership.

F25 Entertainment and Communication

4. Telephone systems

Emergency call

In BMW vehicles with Combox, the emergency call is carried out using NGTP (Next Generation Telematics Protocol). The customer will not notice any difference from the existing emergency call system. With the Combox, the emergency call is always placed via the back up speaker.

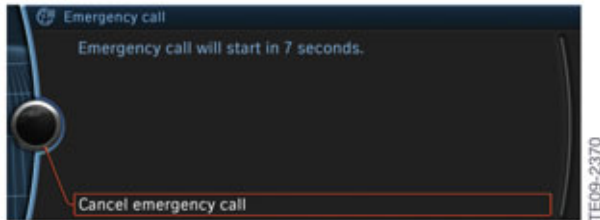

Emergency call display

F25 Entertainment and Communication

5. Connected Drive

BMW Connected Drive is effectively a personal assistant to the driver that employs state-of-the-art technology to provide the driver with all the information he requires. With the market introduction of the F01, BMW Connected Drive was enhanced by a further innovation. With the F25, a number of functions have been introduced to the X3 for the first time.

5.1. Google™ local search

The search engine for special destinations is a function Connected Drive. The special destinations can be selected directly from a list. This list can be found under the "Navigation" menu item in the "Special destinations" sub-menu. It is now also possible in the F25 to search for special destinations with BMW Search . The results returned by the Google™ search engine are used.

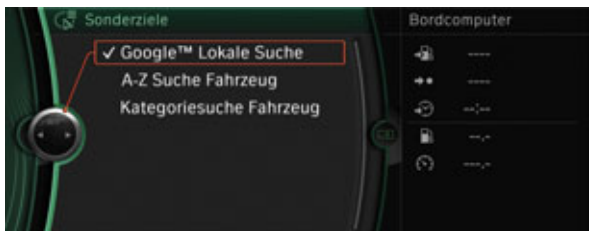

F25 Searching for special destinations

The search results are presented in a list and corresponding locations visualized in a map.



F25 List of search results, Google™ local search

If a large amount of information is listed, you can scroll through the pages. If a phone number is listed, you can call it if necessary.

The Google™ local search is only available in vehicles equipped with the Navigation system (SA 609) and telematics (BMW Assist).

F25 Entertainment and Communication

6. Antenna systems

The F25 has different antenna systems, depending on the optional equipment used:

Antenna	System	Place
FM/AM antenna	Radio	Rear window
SDARS antenna	Radio	Roof antenna
GPS Antenna	Navigation system	Roof antenna
Remote control service antenna	CAS (remote control service)	Rear window
Telephone antenna	Telephone	Roof antenna
Bluetooth antenna	Telephone	Wiring harness
Emergency call antenna	Telematics services	Luggage compartment, right

An antenna rod is not required on the F25 because of the (BMW patented) "Wing" antenna system integrated into the rear window defroster. The FM antennas are obtained from the semicircular shaped heated area and the collecting rails (left and right). The AM (medium wave) antenna is made up of the left wing layout. The antenna of the remote control service (FBD) is in the right wing.

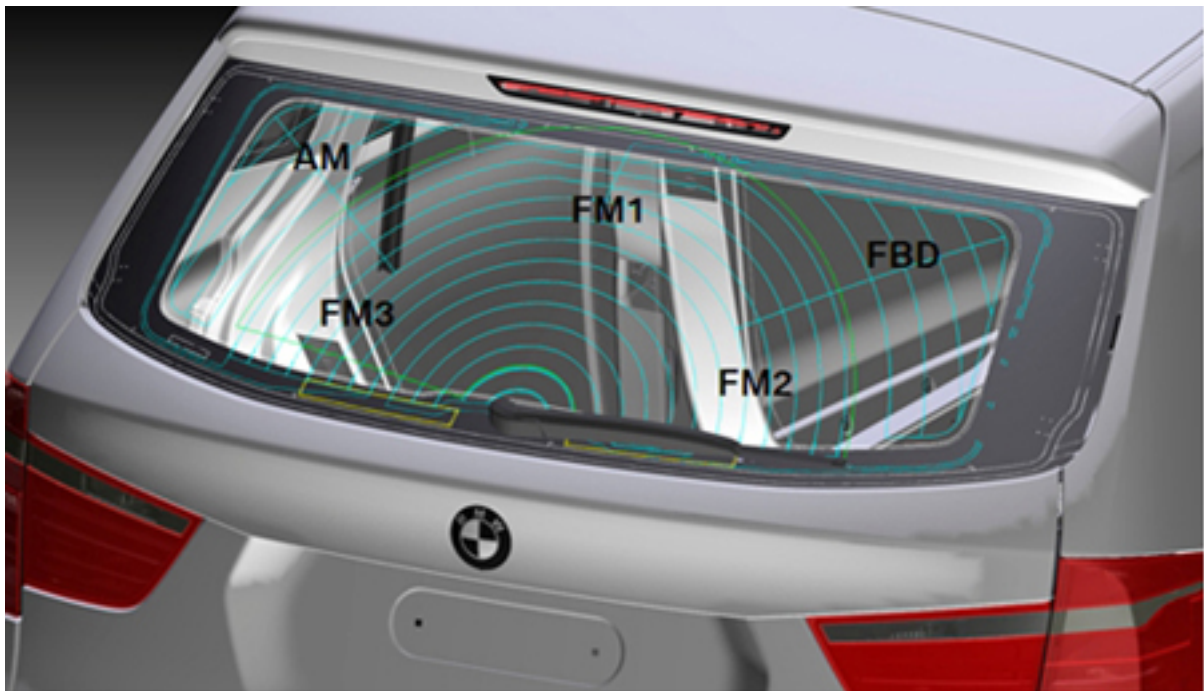

By partitioning the heating element and arranging it in a semicircular pattern ample area has been provided for the most critical antennas. The design also provides an effective defrosting element for the rear window in the event of condensation/icing.

The antenna amplifier for AM/FM and remote control service is located on the center upper part of the window.

F25 Entertainment and Communication

6. Antenna systems

The following graphic provides an overview of the antenna system components.

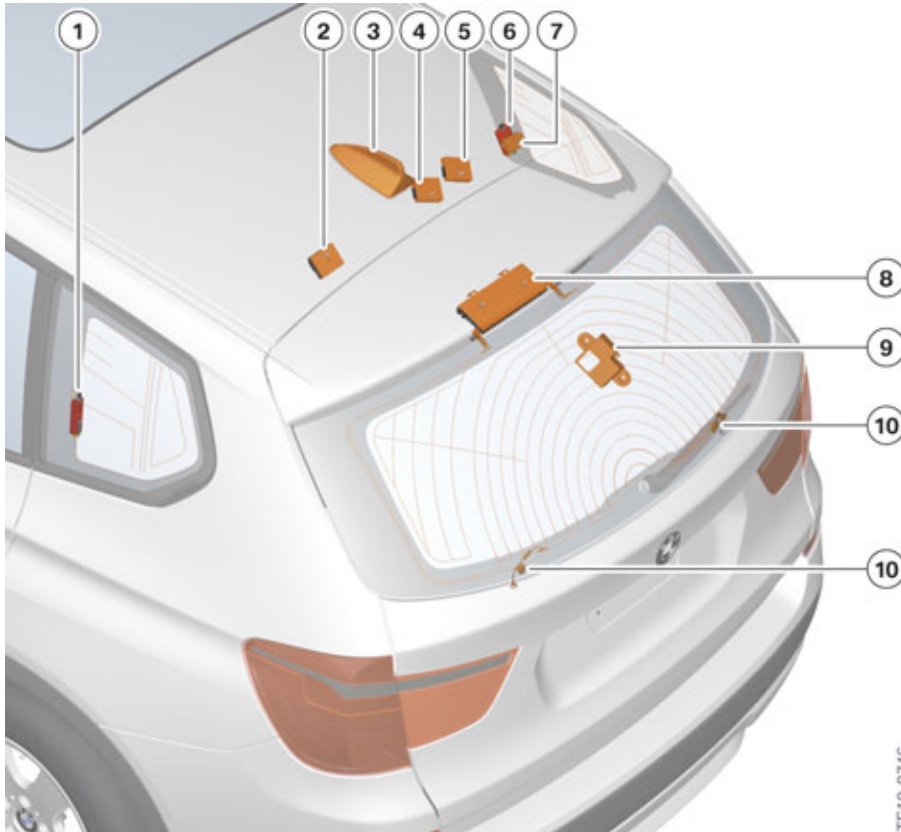

F25 antenna system

TE10-0746

Index	Explanation
1	Amplifier (not US)
2	Interference suppression filter, audio
3	Roof antenna
4	Interference suppression filter, supply wiring harness
5	Interference suppression filter, additional brake light
6	Amplifier (not US)
7	Wave trap, heated rear window
8	Antenna diversity
9	Emergency call antenna
10	Connection, heated rear window

The following graphic shows the antenna diversity connections and the layout of the antennas in the rear window.

F25 Entertainment and Communication

6. Antenna systems

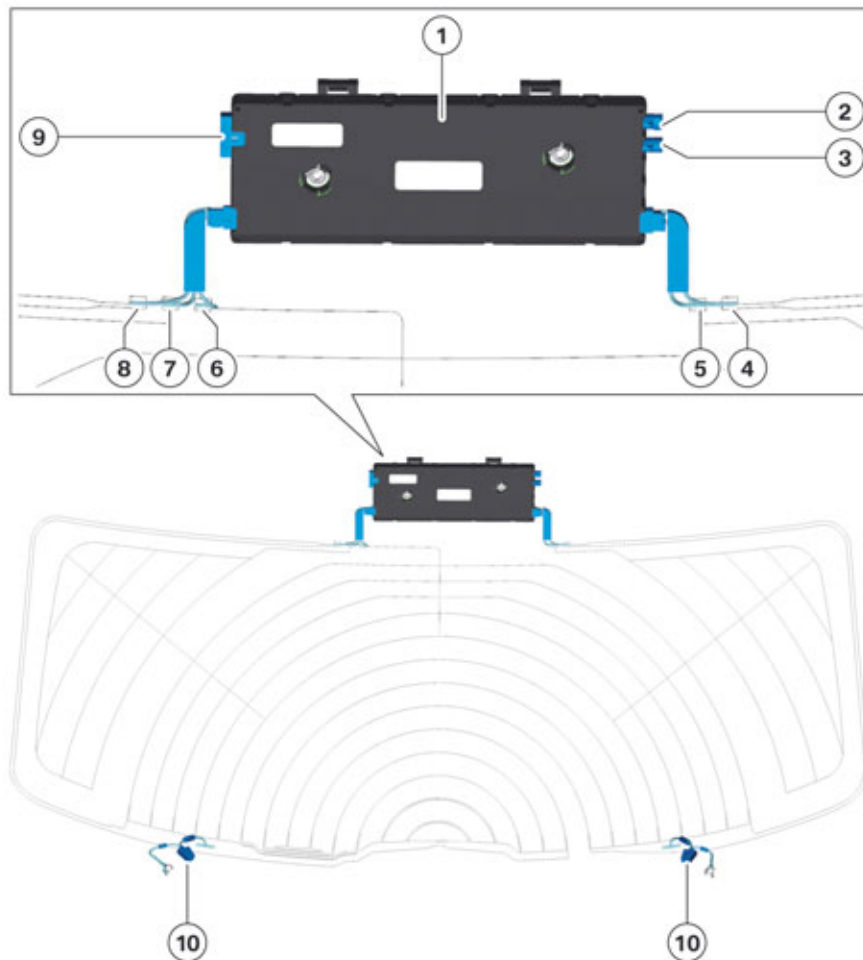

TE10-0747

F25 antenna diversity

Index	Explanation
1	Antenna diversity
2	AM/FM output
3	VICS output
4	FM3 antenna connection
5	AM antenna connection
6	FM1 antenna connection
7	Remote control service antenna connection
8	FM2 antenna connection
9	Connection, wiring harness
10	Connection of heated rear window to wave trap

F25 Entertainment and Communication

6. Antenna systems

6.1. System wiring diagram

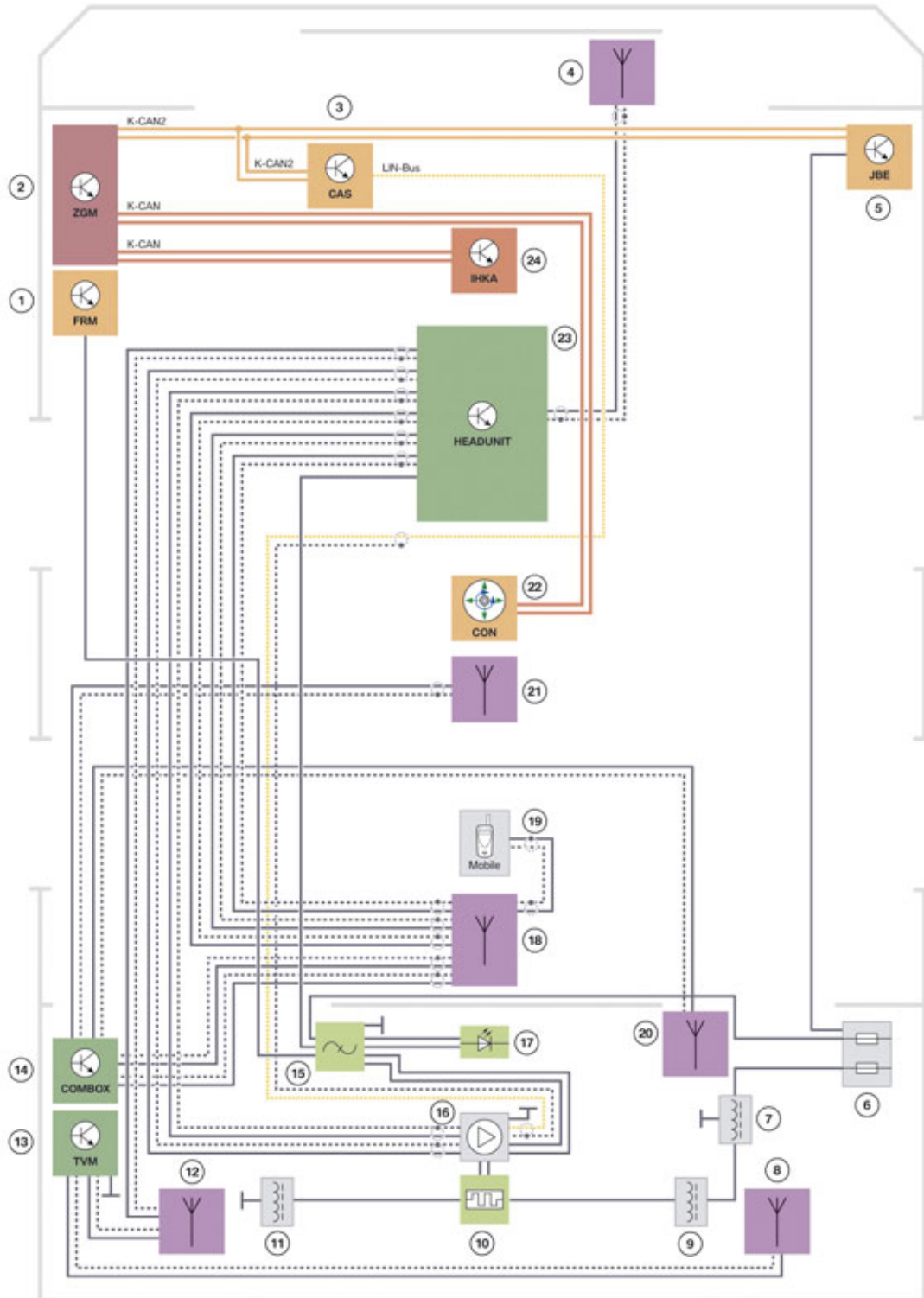

TE10-0748

System wiring diagram of antennas in F25

F25 Entertainment and Communication

6. Antenna systems

Index	Explanation
1	Footwell module (FRM)
2	Central gateway module (ZGM)
3	Car Access System (CAS)
4	Antenna in inside mirror (VICS)
5	Junction box electronics (JBE)
6	Luggage compartment power distribution box
7	Wave trap, heated rear window
8	Antenna, rear right side window (not US)
9	Connection of heated rear window to wave trap
10	Heated rear window
11	Connection of heated rear window to wave trap
12	Antenna, rear left side window (not US)
13	Not for US
14	Combox
15	Interference suppression filter, additional brake light
16	Antenna diversity
17	Additional brake light
18	Roof antenna (telephone, SDARS and GPS)
19	Base plate
20	Emergency call antenna
21	Bluetooth antenna
22	Controller (CON)
23	Headunit (CIC)
24	Automatic integrated heating and A/C control unit (IHKA)



Bayerische Motorenwerke Aktiengesellschaft
Händlerqualifizierung und Training
Röntgenstraße 7
85716 Unterschleißheim, Germany