

Technical training.
Product information.

F25 Passive Safety Systems



BMW Service

Edited for the U.S. market by:
BMW Group University
Technical Training
ST1106 2/1/2011

General information

Symbols used

The following symbol is used in this document to facilitate better comprehension or to draw attention to very important information:



Contains important safety notes and information that needs to be observed strictly in order to guarantee the smooth operation of the system.

Information status and national-market version

BMW Group vehicles meet the requirements of the highest safety and quality standards. Changes in requirements for environmental protection, customer benefits and design render necessary continuous development of systems and components. Consequently, there may be discrepancies between the contents of this document and the vehicles available in the training course.

This document basically relates to the European version of left hand drive vehicles. Some operating elements or components are arranged differently in right-hand drive vehicles than shown in the graphics in this document. Further differences may arise as the result of the equipment specification in specific markets or countries.

Additional sources of information

Further information on the individual topics can be found in the following:

- Owner's Handbook
- Integrated Service Technical Application.

Contact: conceptinfo@bmw.de

©2010 BMW AG, Munich

Reprints of this publication or its parts require the written approval of BMW AG, München

The information contained in this document forms an integral part of the technical training provided by the BMW Group and is intended for its course trainers and participants. Refer to the latest relevant information systems of the BMW Group for any changes/additions to the Technical Data.

Status of the information: **July 2010**
VH-23/International Technical Training

F25 Passive Safety Systems

Contents

1.	Introduction	1
1.1.	Passive Safety.....	1
2.	Models	2
2.1.	Overview.....	2
3.	System overview	3
3.1.	System wiring diagrams.....	3
3.1.1.	Bus diagram.....	4
3.1.2.	System wiring diagram.....	7
4.	Functions	9
4.1.	Functions of Crash Safety Module	9
4.2.	Crash-relevant functions.....	9
4.2.1.	Evaluating the sensor signals.....	10
4.2.2.	Crash detection.....	10
4.2.3.	Trigger time and trigger sequence.....	11
4.2.4.	Triggering the ignition circuit output stages.....	11
4.2.5.	Sending the crash message.....	11
4.2.6.	Crash documentation.....	12
4.2.7.	Emergency call function.....	12
4.3.	System monitoring functions.....	13
4.3.1.	System self test.....	13
4.3.2.	Display of system operability.....	13
4.3.3.	Cyclic monitoring.....	13
4.3.4.	Fault display and fault storage.....	13
4.3.5.	Output of faults (diagnosis).....	14
4.3.6.	Acoustic and visual seat belt warning.....	14
4.3.7.	Deactivating the airbag.....	14
5.	System Components	16
5.1.	Crash Safety Module	16
5.2.	Sensors and switches.....	16
5.2.1.	Lateral and longitudinal acceleration sensor, B-pillar.....	16
5.2.2.	Airbag sensor, front door (pressure).....	17
5.2.3.	Front sensor.....	18
5.2.4.	Sensors in the ICM.....	19
5.2.5.	CIS mat.....	20
5.2.6.	Seat belt buckle switch.....	20
5.2.7.	Emergency call button.....	21
5.3.	Actuators.....	21

F25 Passive Safety Systems

Contents

5.3.1.	Driver's airbag.....	22
5.3.2.	Front passenger airbag.....	22
5.3.3.	Knee airbags.....	23
5.3.4.	Head airbag	24
5.3.5.	Side airbag, front.....	24
5.3.6.	Seat belt	25
5.3.7.	Crash-active headrests, front.....	27
5.3.8.	Safety battery terminal.....	29
5.3.9.	Airbag indicator light.....	30
5.3.10.	Seat belt warning light.....	30
5.3.11.	Indicator lamp for front passenger airbag deactivation.....	30

F25 Passive Safety Systems

1. Introduction

1.1. Passive Safety

The passive safety system of the F25 is based on the objectives and characteristics of current BMW models.

For this, extensive measures were taken on the body and on the occupants safety and protection systems. In addition to the restraint system, a special body structure with a defined crash behavior is also part of the passive safety system. In the event of an collision, the forces introduced are reduced in a defined manner and therefore have less on an impact on the occupants.

The restraint systems ensure that the risk of injury is further reduced.

The 4th generation Advanced Crash Safety Module (ACSM 4) is used as the central airbag control unit in the passive safety system for the F25. As is the case with the 3rd generation ACSM, the central sensor system is outside the control unit, and is not within a separate central sensor either. Instead, the ACSM evaluates sensor data from the ICM.

The front vehicle of the F25 was optimized for pedestrian protection. The soft deformation paths under the hood ensure compliance with all legal requirements for pedestrian protection. An active hood not required with the F25.

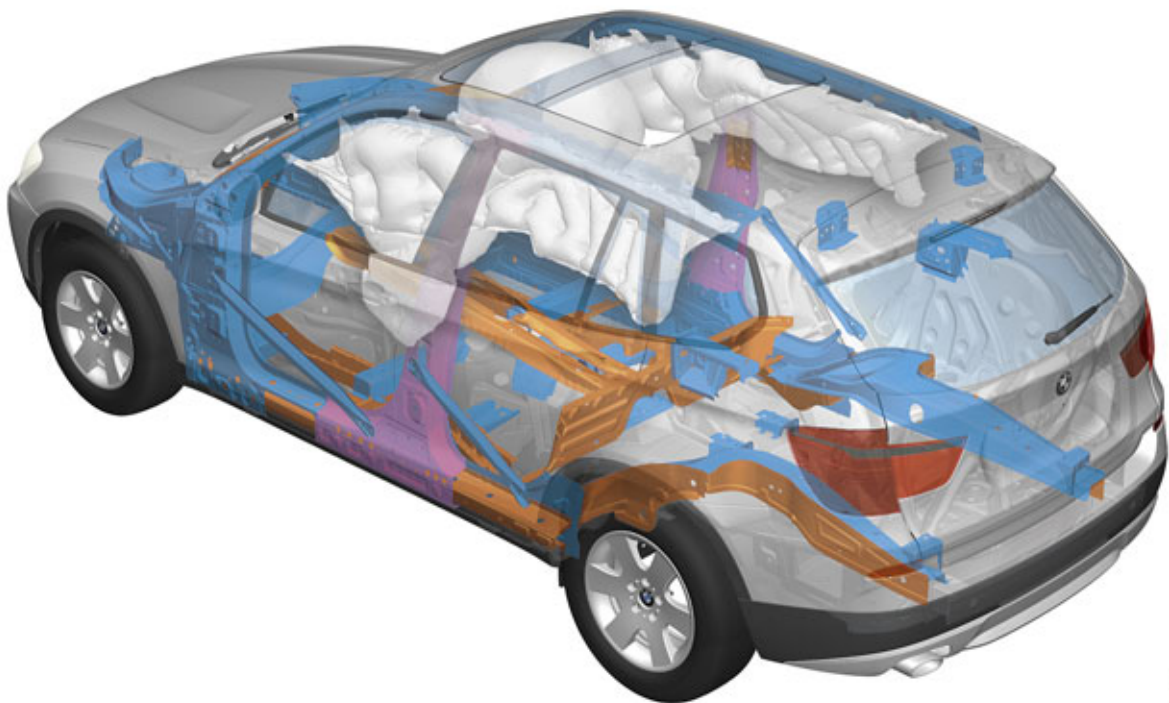

F25 Passive safety system

TE10-1148

F25 Passive Safety Systems

2. Models

2.1. Overview

In the 4th generation, a Crash Safety Module is installed as the passive safety system in the F25. The following table provides an overview of the versions installed for different models:

Series	Model	Used as of	Version
E60	5-Series Sedan	09/2005	ACSM 1
E61	5-Series Touring	09/2005	ACSM 1
E63	6-Series Coupé	09/2005	ACSM 1
E64	6-Series Convertible	09/2005	ACSM 1
E83	X5 SAV	11/2003	MRS 4 RD
E85	Z4 Roadster	01/2006	ACSM 1
E86	Z4 Coupé	05/2006	ACSM 1
E88	1-Series Convertible	04/2008	ACSM 2
E70	X5 SAV	11/2006	ACSM 2
E71	X6 SAC	04/2008	ACSM 2
E93	3-Series Convertible	03/2007	ACSM 2
F01	7-Series Sedan	11/2008	ACSM 3
F02	7-Series Sedan long version	11/2008	ACSM 3
F07	5-Series Gran Turismo	10/2009	ACSM 3
F10	5-Series Sedan	03/2010	ACSM 3
F25	X3 SAV	11/2010	ACSM 4

F25 Passive Safety Systems

3. System overview

3.1. System wiring diagrams

The following bus overview shows the vehicle circuit structure of the F25 and incorporation of the modules on the PT-CAN.

F25 Passive Safety Systems

3. System overview

3.1.1. Bus diagram

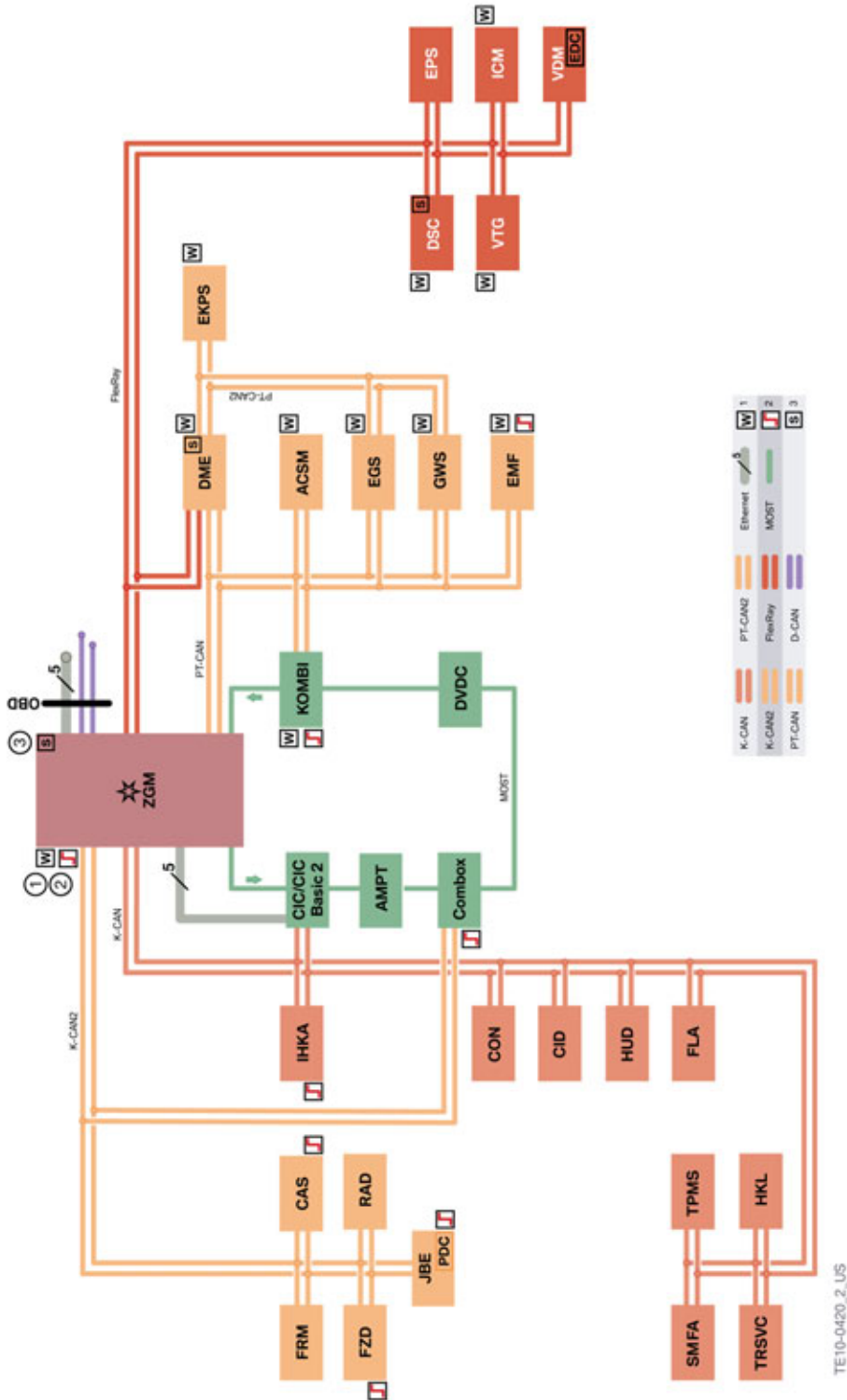

F25 Bus overview

F25 Passive Safety Systems

3. System overview

Index	Explanation
1	Wakeable control units
2	Control units with wake-up authorization
3	Start-up node control units for starting up and synchronizing the FlexRay bus system
ACSM	Advanced Crash Safety Module
AMPT	Top HiFi amplifier
CAS	Car Access System
CID	Central information display
COMBOX	Combox (Combox multimedia, Combox multimedia with telematics)
CON	Controller
D-CAN	Diagnosis-on-Controller Area Network
DME	Digital Motor Electronics
DSC	Dynamic Stability Control
DVDC	DVD changer
EDC	Electronic Damper Control
EGS	Electronic transmission control
EKPS	Electronic fuel pump control
EMF	Electromechanical parking brake
EPS	Electronic power steering (electromechanical power steering)
Ethernet	Cable-based data network technology for local data networks
FLA	High-beam assistant
FlexRay	Fast, preset and fault-tolerant bus system for use in automotive sector
FRM	Footwell module
FZD	Roof function center
GWS	Gear selector switch
HEADUNIT	Headunit (car information computer or car information computer basic II)
HKL	Automatic operation of tailgate
HUD	Head-Up Display
ICM	Integrated Chassis Management
IHKA	Automatic integrated heating and A/C control unit
JBE	Junction box electronics
K-CAN.	Body controller area network
K-CAN2	Body controller area network 2
KOMBI	Instrument panel
MOST	Media Oriented System Transport

F25 Passive Safety Systems

3. System overview

Index	Explanation
OBD	On-board diagnosis (diagnostic socket)
PDC	Park Distance Control
PT-CAN	Powertrain controller area network
PT-CAN 2	Powertrain controller area network 2
RAD	Radio
SMFA	Driver's seat module
TPMS	Tire Pressure Monitoring System
TRSVC	Control unit for camera systems
VDM	Vertical dynamics management
VTG	Transfer box
ZGM	Central gateway module

F25 Passive Safety Systems

3. System overview

3.1.2. System wiring diagram

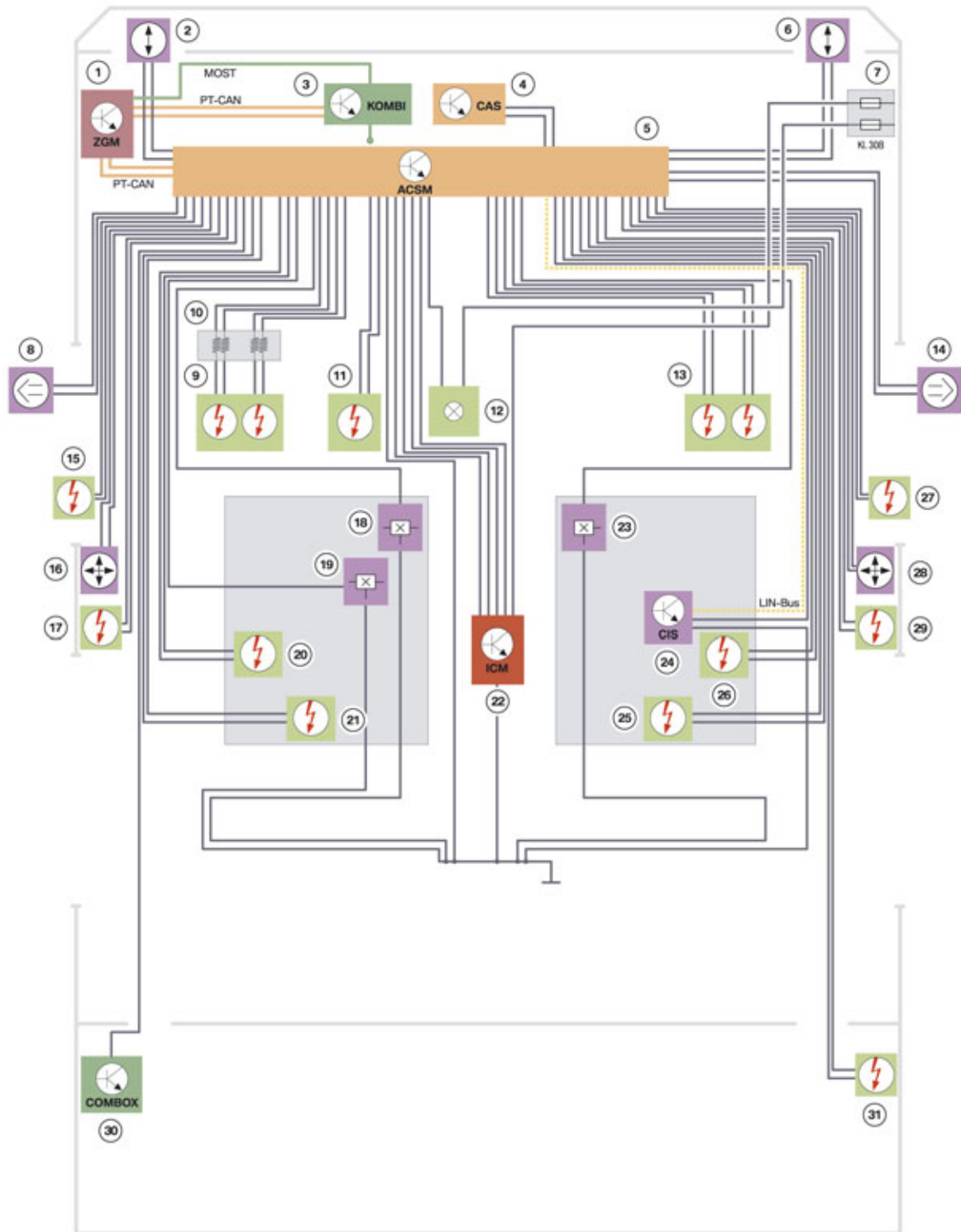

F25 System wiring diagram

TE10-0422

F25 Passive Safety Systems

3. System overview

Index	Explanation
1	Central gateway module
2	Front sensor, left engine support
3	Instrument panel
4	Car Access System
5	Crash Safety Module
6	Front sensor, right engine support
7	Terminal 30B
8	Airbag sensor, front door, left (pressure)
9	Driver's airbag, two-stage
10	Clock spring
11	Knee airbag, driver
12	Indicator lamp for front passenger airbag deactivation
13	Front passenger airbag, two-stage
14	Airbag sensor, front door, right (pressure)
15	Head airbag, left
16	Acceleration sensor, B-pillar on left
17	Automatic tensioner with linear mechanical force limiter, driver
18	Seat belt buckle contact, driver
19	Seat-position sensor, driver
20	Side airbag, driver's side
21	Crash-active headrest, driver
22	Integrated Chassis Management
23	Seat belt buckle contact, front passenger
24	Seat occupancy mat, CIS mat
25	Crash-active headrest, front passenger
26	Side airbag, front passenger
27	Head airbag, right
28	Acceleration sensor, B-pillar on right
29	Automatic tensioner with linear mechanical force limiter, front passenger
30	COMBOX
31	Safety battery terminal

F25 Passive Safety Systems

4. Functions

4.1. Functions of Crash Safety Module

The function of the Crash Safety Module is to permanently evaluate all sensor signals in order to identify a crash situation. As a result of the sensor signals and their evaluation, the Crash Safety Module identifies the direction of the crash and the severity of the impact.

In addition, information on the seat occupancy of the front passenger seat and whether or not the driver's and/or front passenger's seat belt is fastened is used as input. From this information, measures are taken to selectively activate the necessary restraint systems.

The Crash Safety Module monitors the system itself and indicates when it is ready for operation by switching off the airbag indicator light.

If an error occurs during operation this is stored in a fault memory and can be read out for diagnosis purposes.

If a crash situation is detected, a crash message is sent to the other components in the data bus network as notification. The relevant control units respond to this signal by executing their own activities according to the severity of the crash.

The activities include:

- Opening the central locking system
- Activation of hazard warning flasher
- Switching on the interior light
- Deactivating the fuel pump
- Automatic emergency call.

An additional function of the Crash Safety Module is the acoustic seat belt warning that reminds the driver and front passenger using visual and acoustic signals to fasten their seat belts.

The functions of the Crash Safety Module are generally divided into the following areas:

- Crash-relevant functions
- System monitoring functions
- Additional convenience functions.

4.2. Crash-relevant functions

The Crash Safety Module must fulfil the following crash-relevant functions:

- Evaluating the sensor signals
- Crash detection
- Specifying the trigger time and trigger sequence
- Triggering the ignition circuit output stages

F25 Passive Safety Systems

4. Functions

- Sending the crash message to all bus users
- Crash documentation
- Emergency call function.

4.2.1. Evaluating the sensor signals

The sensors serve to identify and verify front-end, side-on and rear-end crashes.

The sensors are directly connected to the Crash Safety Module where their signals are evaluated and processed.

4.2.2. Crash detection

The US version of the vehicles is also equipped with the following sensors:

- one airbag sensor to monitor the pressure in each of the front doors (blue).
- one front sensor on each of the engine supports (red).
- one roll rate sensor in the ICM
- one vertical acceleration sensor in the ICM

The front sensors on the engine supports assist with the identification of a front-end crash and the corresponding severity.

The airbag sensors in the car doors (blue) assist with the identification of a side-on crash.

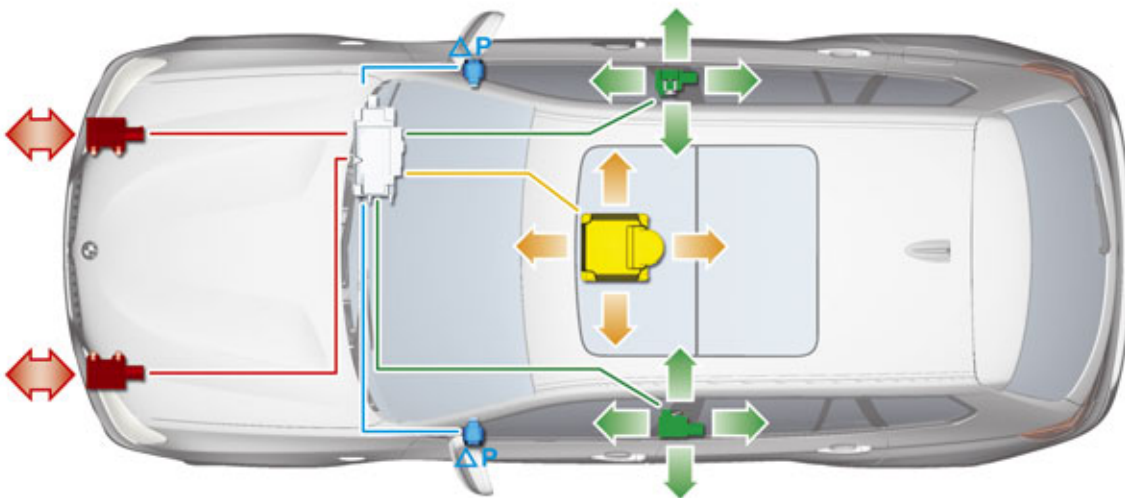

TE10-0943

F25 Passive Safety Systems

4. Functions

4.2.3. Trigger time and trigger sequence

The Crash Safety Module uses the values transmitted by the sensors to determine the direction and severity of the crash.

In the case of a front-end crash, corresponding high acceleration values from the longitudinal acceleration sensors in the B-pillar and ICM respectively must be detected for example. An algorithm uses the accelerations to calculate the severity and direction of the crash. This information is used to assist calculation of the trigger times and sequence in which the restraint systems are activated.

A possible imminent rollover is also detected and the appropriate protection systems are energized.

4.2.4. Triggering the ignition circuit output stages

The Crash Safety Module is supplied by the Car Access System 4 CAS 4 with terminal 30b. The Crash Safety Module is in offline mode with terminal 30B. This means that it is active on the data bus and can perform all diagnostic functions. Triggering of the ignition circuits is blocked and is only enabled as of terminal 15 once the system self-test is complete. The Crash Safety Module is also ready for ignition, even with the logical terminal R after engine off.

The ignition capacitors are recharged via a switching controller. These ignition capacitors make the firing energy available in the event of a crash. If the voltage supply is interrupted during a crash, the ignition capacitors serve briefly as an energy reserve.

The ignition circuit output stages consist of a high-side and a low-side power switch. The high-side power switch controls the ignition voltage, while the low-side power switch switches to ground. The ignition circuit output stages are controlled by a micro-controller.

The high-side and low-side power switches also serve the purpose of checking the ignition circuits during the system self-test.

4.2.5. Sending the crash message

In the event of a collision involving activation of the restraint systems, the Crash Safety Module sends a crash message to the bus users in the bus-system network. In tandem with this, the Combox is prompted to send an emergency call via a direct single-wire connection.

As a result, the respective control units perform the following functions depending on the crash severity:

Function	Control unit
Switch off electric fuel pump	Digital Motor Electronics (DME) or via electronic fuel pump control (EKPS)
Release central locking system	Junction box electronics JBE
Switch on hazard warning flashers	Footwell module FRM
Switch on interior lights	Footwell module FRM
Transmit emergency call (only with airbag deployment)	Combox

F25 Passive Safety Systems

4. Functions

4.2.6. Crash documentation

In the event of a collision where one or more actuators are activated, a crash entry is stored in a non-erasable memory. After three crash entries, a non-erasable fault entry is stored in the fault memory with the instruction to replace the Crash Safety Module.



The three crash entries could also be stored during the course of an accident. Each crash entry is assigned a system time. The control unit remains capable of firing even after three crash entries. The crash entries cannot be erased and serve the purpose of subsequent device diagnosis. A maximum of three crash entries can be stored. The control unit must then be replaced.

4.2.7. Emergency call function

The emergency call function is made possible with the BMW Assist infrastructure. Another prerequisite for being able to make an emergency call is the availability of a telephone network.

In addition to the emergency call function included in the Combox multimedia with telematics, the customer also has access to a range of other convenience functions.

A manual and automatic emergency call function is included as standard. The customer also has the option of activating a breakdown call. If the vehicle is equipped with a Combox, a telematics antenna, an emergency antenna, a hands-free system and a GPS antenna for determining the location are also installed.

Manual emergency call

Drivers who are not directly involved in the accident can use the manual emergency call to request assistance.

The emergency call button is located in the roof function center and is connected to the Combox directly.

Voice contact with the relevant service provider is established by pressing the emergency call button. The voice contact is indicated by a flashing LED in the switch.

Automatic emergency call

The Crash Safety Module sends a message to the Combox in the event of an accident with corresponding crash severity. The Combox sends an emergency call, and also the location of the vehicle if available.

Attempts are made at the same time to establish a voice contact with the occupants of the vehicle in order to obtain more detailed information about the accident (e.g. number of injured persons). Additional rescue operations are initiated accordingly.

Extended automatic emergency call

In addition, the emergency call (Advanced Automatic Crash Notification) function features in vehicles with BMW Assist.

F25 Passive Safety Systems

4. Functions

The risk of injury is determined using the different sensor data obtained by the Advanced Automatic Crash Notification system and transmitted to the rescue coordination center.

The emergency call contains additional specific information on the circumstances of the accident. This means that more precise information regarding the accident and risk of injury is therefore available at the call center and can be forwarded to the rescue coordination center. The emergency coordination center can then initiate the appropriate measures.

4.3. System monitoring functions

The Crash Safety Module has the following system monitoring functions:

- System self-test (pre-drive check)
- Display of system operability
- Cyclic monitoring
- Fault display and fault storage
- Output of faults (diagnosis)
- Acoustic and visual seat belt warning
- Deactivation of the front passenger airbag and side airbag

4.3.1. System self test

The Crash Safety Module performs a system self test from terminal 15. The airbag indicator light is energized for roughly five seconds during the system self test.

Once the system self test is complete and no faults have been identified, the airbag indicator light goes out and the system is ready to operate.

4.3.2. Display of system operability

The airbag indicator light in the instrument panel goes out to indicate that the Crash Safety Module is ready for operation.

4.3.3. Cyclic monitoring

Once the system self-test has been successfully concluded and the system is ready for operation, a cyclic monitoring procedure is performed for fault monitoring purposes. Cyclic monitoring serves the purpose of internal diagnosis of the control unit and the overall airbag system. Cyclical monitoring takes place continuously from terminal 15. This also continues when logical terminal R is reached after the engine is switched off.

4.3.4. Fault display and fault storage

The Crash Safety Module has a non-volatile fault memory. The airbag indicator light lights up to indicate a fault entry.

F25 Passive Safety Systems

4. Functions

Events, such as the activation of an airbag or belt tensioner, are also stored in the fault memory.



If the fault memory contains the entry that the restraint system has been activated, this only means the ignited restraint system is not available for further activation and not that it malfunctioned during the crash.

4.3.5. Output of faults (diagnosis)

The fault memory can be read out via the diagnostic interface with the assistance of the Integrated Service Technical Application ISTA in the BMW diagnosis system. After rectifying the faults or after renewing activated components, the fault memory can be cleared with the diagnosis command "Clear fault memory".

4.3.6. Acoustic and visual seat belt warning

An acoustic and visual seat belt warning is a standard feature of all vehicles equipped with the Crash Safety Module. The Crash Safety Module records whether or not the driver or front passenger have fastened their seat belts. If they have not, an acoustic and visual warning is output to remind them to fasten their seatbelts. Both seat belt buckle switches are monitored separately.

4.3.7. Deactivating the airbag

Provision is made in the vehicle for the airbag to be deactivated automatically in order to satisfy the regulations of the National Highway Traffic Safety Administration NHTSA. The airbag is deactivated when the child seats listed in the regulation are used.

The Occupant Classification 3 mat (OC3 mat) has been replaced with the Capacitive Interior Sensing mat (CIS mat) on all new BMW models.

The CIS mat uses two elements: a sensor wire that runs parallel to the seat heating in the seat cushion and an evaluation unit. The CIS mat measures the capacity and ohmic resistance between the sensor wire (anode) and the vehicle ground (cathode) at a frequency of 120 kHz. The CIS mat determines from the change in capacity and resistance whether the front passenger seat is occupied by an adult or a child in a child seat.

F25 Passive Safety Systems

4. Functions



Measuring procedure of CIS mat using F07 as example

The deactivation of the front passenger airbag and side airbag on the front passenger side is signalled by the indicator lamp for front passenger airbag deactivation.

The indicator lamp for front passenger airbag deactivation in the roof function center lights up if a child restraint system that has been tested in accordance with the NHTSA regulations and is holding a small child is detected on the front passenger seat, or if the front passenger seat is unoccupied.

The display brightness is controlled by automatic regulation of the display illumination.

F25 Passive Safety Systems

5. System Components

5.1. Crash Safety Module

The Crash Safety Module is accommodated in a housing with three sockets.

Two sockets serve to connect the wiring harness. An additional socket is provided for the interior wiring harness.

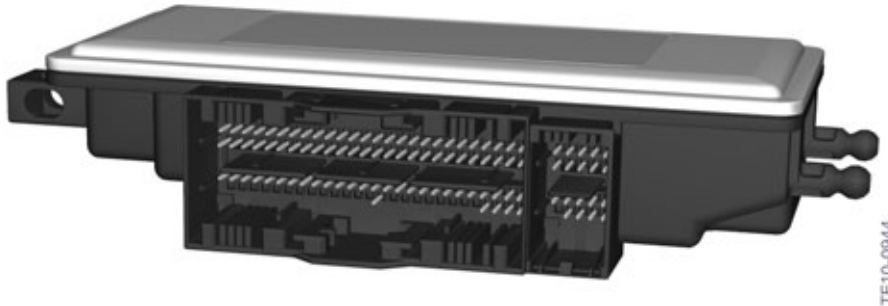

F25 Crash Safety Module

The Crash Safety Module is located behind the glove box.

The Crash Safety Module no longer contains any sensors. The sensors are located in the ICM on the transmission tunnel.

5.2. Sensors and switches

The following sensors and switches are installed:

- Lateral and longitudinal acceleration sensors in ICM
- Roll rate sensor in the ICM
- Vertical acceleration sensor in ICM
- Lateral and longitudinal acceleration sensors on the B-pillars
- One airbag sensor in each of the front doors (pressure)
- One front sensor on each of the engine supports
- CIS mat
- Seat belt buckle switch
- Emergency call button

5.2.1. Lateral and longitudinal acceleration sensor, B-pillar

The lateral and longitudinal acceleration sensors in the B-pillars assist with the identification of front-end crashes, side-on crashes and rear-end crashes.

The B-pillar airbag sensor consists of a longitudinal acceleration sensor and a lateral acceleration sensor. The acceleration sensors measure both the acceleration and the deceleration in the X and Y directions. The resultant from the X and Y signals is the definitive factor in identifying the direction of the

F25 Passive Safety Systems

5. System Components

crash. The airbag sensors in the B-pillar assist with the identification of front-end, side-on and rear-end crashes. The B-pillar airbag sensors on the left and right are of identical design and are allocated by way of mechanical coding during installation.

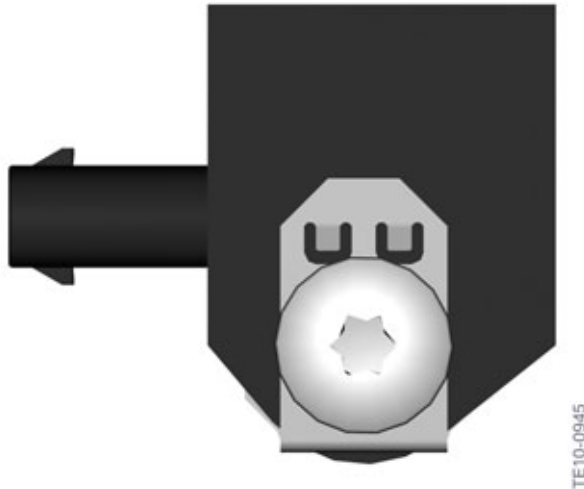

F10 Lateral and longitudinal acceleration sensor, B-pillar

5.2.2. Airbag sensor, front door (pressure)

The purpose of the airbag sensors in the front doors is to assist with identifying side-on crashes. In addition to the high lateral acceleration values that are present, the pressure in the door cavity also increases in the event of a side-on crash.

The airbag sensors in the front doors serve to verify the plausibility of the acceleration signals from the B-pillar airbag sensors and the ICM when a side crash is detected. The airbag sensors are situated in the inner door panel of the front doors and measure the increase in pressure in the event of a side collision. In the event of a side collision with the door, the outer door panel is pressed inward, thus reducing the door interior and increasing the pressure. This pressure change is measured by the airbag sensors. The airbag sensor also includes electronics, in addition to the pressure sensor, that digitize the pressure readings and transmit them cyclically to the Crash Safety Module. The data is transferred in the same way as the B-pillar airbag sensors. The pressure readings are evaluated in the Crash Safety Module.

F25 Passive Safety Systems

5. System Components

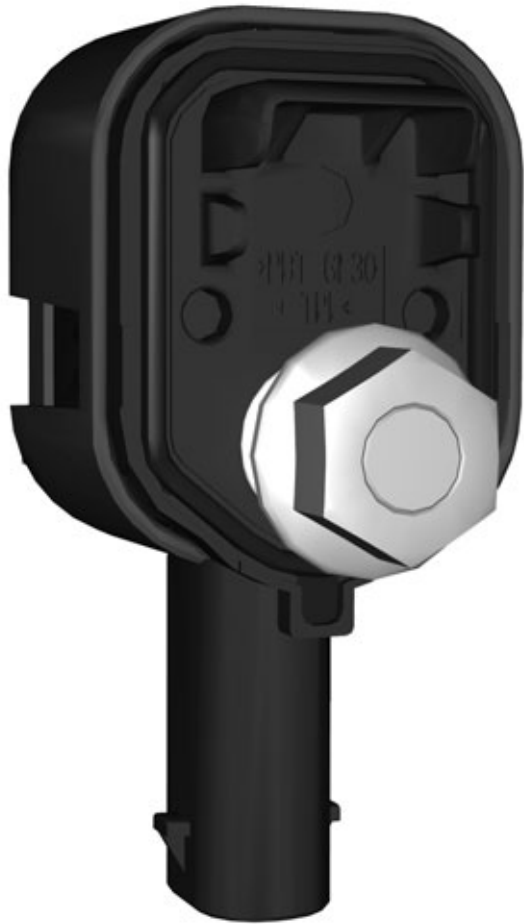

F25 Airbag sensor, front door (pressure)

5.2.3. Front sensor

Two front sensors are installed in the front area of the engine support. The measured values are forwarded to the Crash Safety Module where they are evaluated.

The sensors in the front area of the side member on the left and right assist with identification of a front-end crash.

They deliver additional information to the crash safety module on the characteristics and severity of the collision. Each sensor consists of an acceleration sensor for recording the deceleration, signal processing technology and an ASIC for data transfer. The measured values are sent in the form of a data telegram to the crash safety module and are used calculate the crash severity.

F25 Passive Safety Systems

5. System Components



TE08-1056

F25 Front sensor, engine support

5.2.4. Sensors in the ICM

The ICM control unit is located centrally on the transmission tunnel. In addition to the driving dynamics control sensors, the ICM in the F25 also incorporates longitudinal and lateral acceleration sensors for crash detection. The sensors in the ICM of F25 replace the central sensor that was used with the ACSM 3.

The ICM is connected to the ACSM directly via four lines for the purpose of transmitting longitudinal and lateral acceleration sensor data along with sensor data of the roll rate sensor and the vertical acceleration sensors.

The sensor data of the ICM assists the ACSM with side-on or front-end crash identification and roll-over detection.



TE10-0947

F25 ICM

F25 Passive Safety Systems

5. System Components

5.2.5. CIS mat

The capacitive interior sensing mat (CIS mat) is fitted in the front passenger seat instead of the seat occupancy mat. The CIS mat can detect whether the front passenger seat is occupied by an adult or a child in a child seat. The indicator lamp for front passenger airbag deactivation lights up to signal deactivation of the front passenger front and side airbags.

5.2.6. Seat belt buckle switch

The seat belt buckle switches are located in the seat belt buckles of the driver and front passenger seat.

The seat belt buckle switch detects whether the seat belt buckle tongue is in the seat belt buckle. The Crash Safety Module supplies power to the sensors and performs the evaluation.

From terminal 15, the seat belt buckle switch is permanently monitored and used for the visual and acoustic seat belt warning and also to determine which restraint systems are triggered.



TE08-1294

F25 Seat belt buckle switch

F25 Passive Safety Systems

5. System Components

5.2.7. Emergency call button

The emergency call button is located in the roof function center.



F25 Roof function center with emergency call button

5.3. Actuators

The following actuators are installed in the F25:

- Two-stage driver's airbag
- Two-stage front passenger airbag
- Knee airbag on left
- Head airbag on left and right
- Side airbag on front left and right
- Automatic tensioner with linear mechanical force limiter
- Crash-active headrests on front left and right
- Safety battery terminal.

In addition, the following indicator lights inform the vehicle occupants about the condition of the safety systems:

- Airbag indicator light
- Seat belt warning light
- Indicator lamp for front passenger airbag deactivation

The following graphic shows the airbags in the activated state. Depending on the type of crash, only specific airbags are activated.

F25 Passive Safety Systems

5. System Components

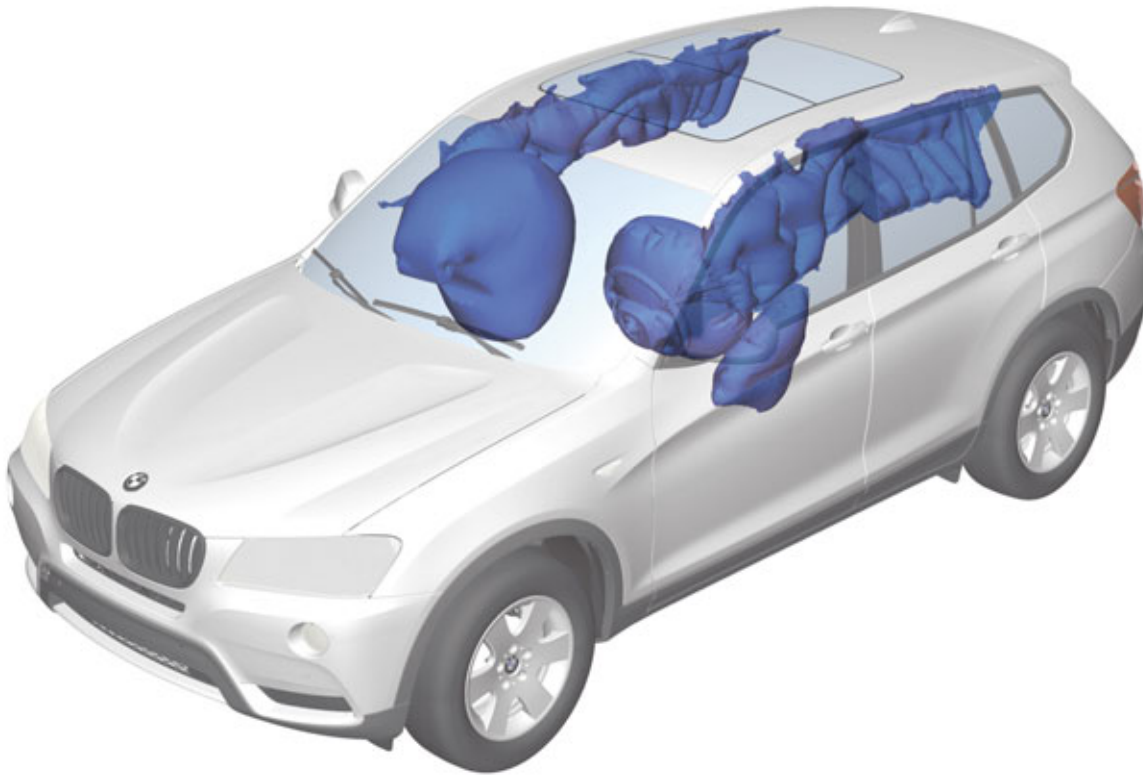

TE10-1147

F25 Airbags

5.3.1. Driver's airbag

The purpose of the driver's airbag is to reduce the risk of injury to the driver in combination with the seat belt in the event of a front-end collision. The driver's airbag is located in the steering wheel impact plate.

A two-stage generator is installed which can be used to activate the stages with a time difference, depending on the severity of the crash that has been detected.

5.3.2. Front passenger airbag

The purpose of the front passenger airbag is to reduce the risk of accident to the front passenger in the event of a front-end collision. The front passenger airbag is located in the dashboard. When the front passenger airbag expands, the dashboard tears open at defined points. The front passenger airbag opens towards the windscreen, emerges in the upwards direction and is supported on the windscreen and dashboard.

A two-stage generator is installed in which can be used to activate the stages with a time difference, depending on the severity of the crash that has been detected.

F25 Passive Safety Systems

5. System Components

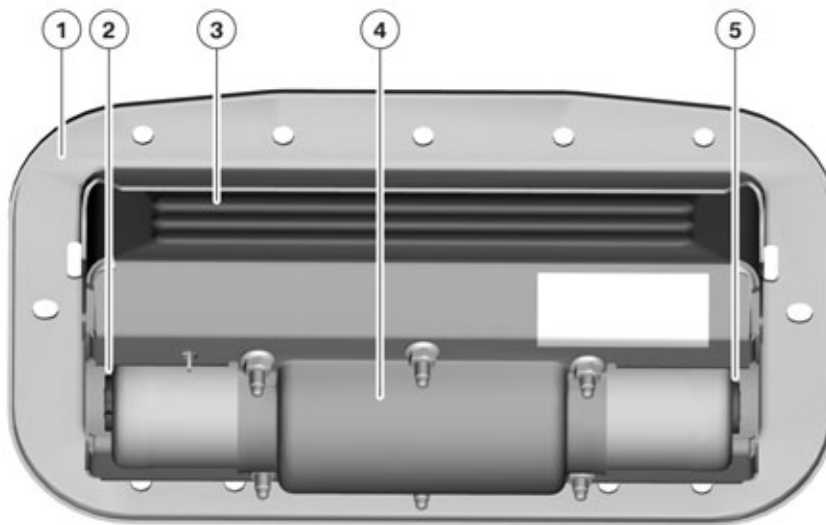

TE10-0953

F25 Front passenger airbag

Index	Explanation
1	Cover
2	First stage ignition squib
3	Housing, airbag
4	Gas generator
5	Second stage ignition squib

5.3.3. Knee airbags

Knee airbags are used for the front driver and passenger.

F25 Passive Safety Systems

5. System Components



TE10-0951

F25 Knee airbag

5.3.4. Head airbag

Head airbags are installed in the F25 to protect the occupant's head.

The head airbag extends from the A-pillar to the C-pillar and covers the entire area of the side windows. It expands between the occupants and side structure.

System features:

- Extended covered area across all front and rear side windows
- Protection of occupants from glass splinters
- Covered area for different-sized occupants optimized.

5.3.5. Side airbag, front

As with all current models, the side airbag at the front ignites out of the front seat backrest.

The side airbags and gas generators are accommodated in a plastic housing, the airbag module. This is installed in the front seat backrest and is disguised by the rear panel.

If activated, the side airbag emerges outwards between the backrest frame and backrest rear panel and spreads between the side structure and occupant.



It is important to ensure that no additional seat covers are fitted as they would greatly impair the function of the side airbag, or even immobilize it altogether.

F25 Passive Safety Systems

5. System Components

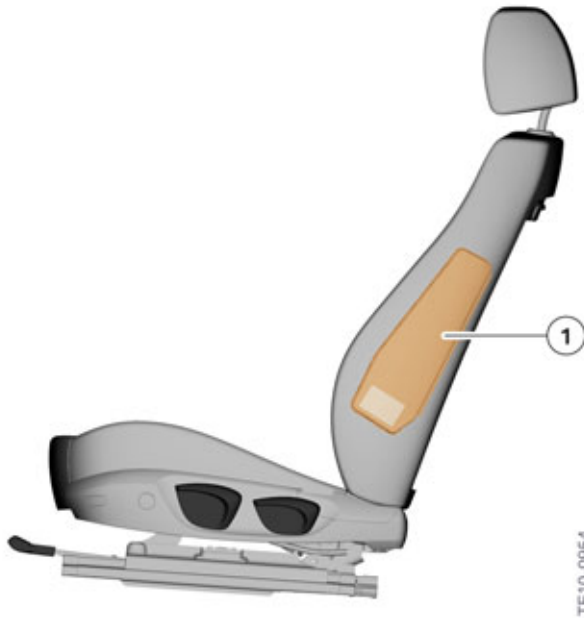

F25 Seat with side airbag

Index	Explanation
1	Side airbag

5.3.6. Seat belt

The familiar three-point seat belts are used as the seat belt systems in the F25.



F25 Seat belt

F25 Passive Safety Systems

5. System Components

Index	Explanation
1	Seat belt buckle tensioner (not for US)
2	Side airbag
3	Automatic tensioner with linear mechanical force limiter (US version)

Automatic reel with linear force limiter

In the event of a front-end or rear-end crash or rollover, the automatic reel blocks the extension of the seat belt in order to restrain the occupants. The belt force limiter limits the load exerted by the belt on the occupants during the accident and the airbags provide the remaining restraining effect. In terms of their effect therefore, the airbags and seat belts are precisely harmonized with one another. The load on the occupants is reduced by means of reduced belt forces and extensive support by the airbag.

With the linear system, the belt force is limited by the twisting motion of a torsion bar spring in the seat belt inertia reel.



When the belt force limiter responds, the airbag also absorbs the remaining forces not taken up by the seat belt. For this reason, the airbag and seat belt are precisely matched to one another.

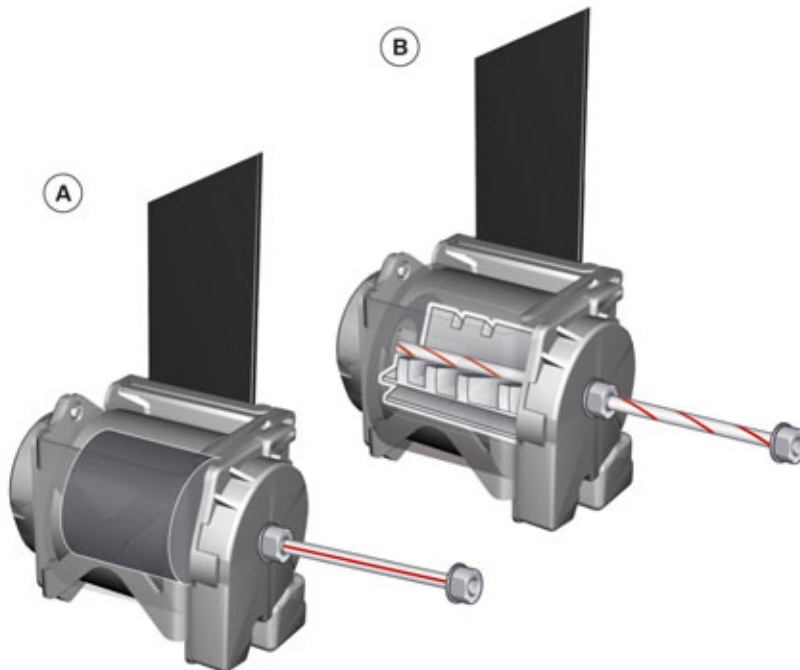

TE10-0950

F25 Automatic reel with force limitation

F25 Passive Safety Systems

5. System Components

Index	Explanation
A	Torsion bar spring unstressed
B	Torsion bar spring twisted

Automatic tensioner with linear mechanical force limiter

An automatic tensioner with linear mechanical force limiter for the driver and front passenger is built into the F25. In addition to force limitation effected by a torsion bar spring, the seat belt strap is retracted with the assistance of a gas generator in order to reduce belt slack prior to forwards displacement of the occupant.

By harmonizing the individual passive safety components, the seat belt with tensioner, force limiter and airbag, the kinetic energy acting on the occupants is dissipated more evenly for the duration of the crash. Thus lower occupant stress values are achieved. By using the automatic tensioner with linear mechanical force limiter this eliminates the need for an additional seat belt buckle tensioner.

The automatic tensioners with linear mechanical force limiter used in the F25 have been developed based on the system used in the E70.

5.3.7. Crash-active headrests, front

Two versions are available for the F25, depending on which seat is installed. Both are a head restraint with a pyrotechnic actuator that optimizes the distance and height in relation to the head if a rear-end collision of sufficient force occurs. This reduces the load on the cervical vertebrae in the event of a rear-end collision. The head restraint is activated early, even prior to backwards displacement of the occupant's head.

To provide the best possible degree of comfort, the front section of the manually adjustable head restraint can be pulled forwards or pushed backwards by approximately 30 mm. The setting is made in two stages. This allows for three different positions for the head restraint depth adjustment.

F25 Passive Safety Systems

5. System Components

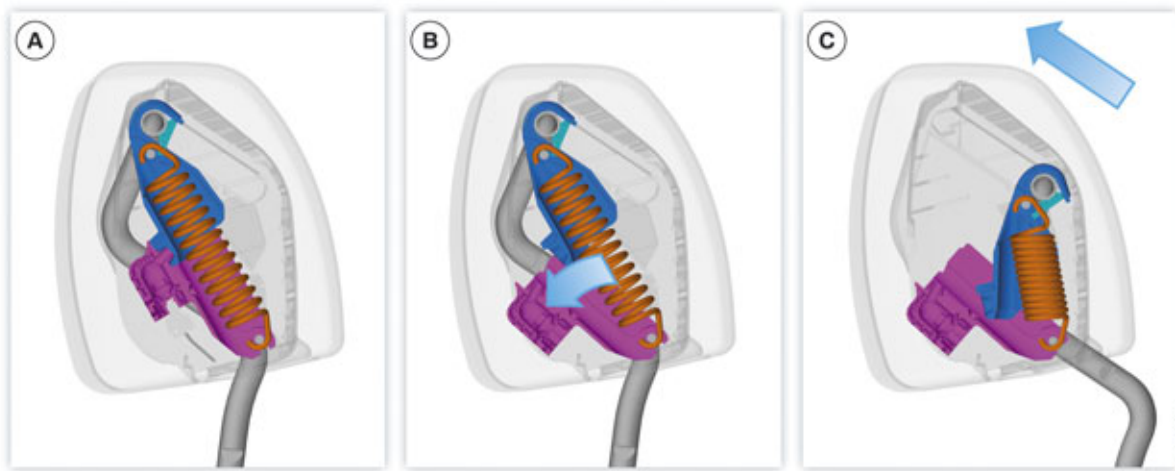
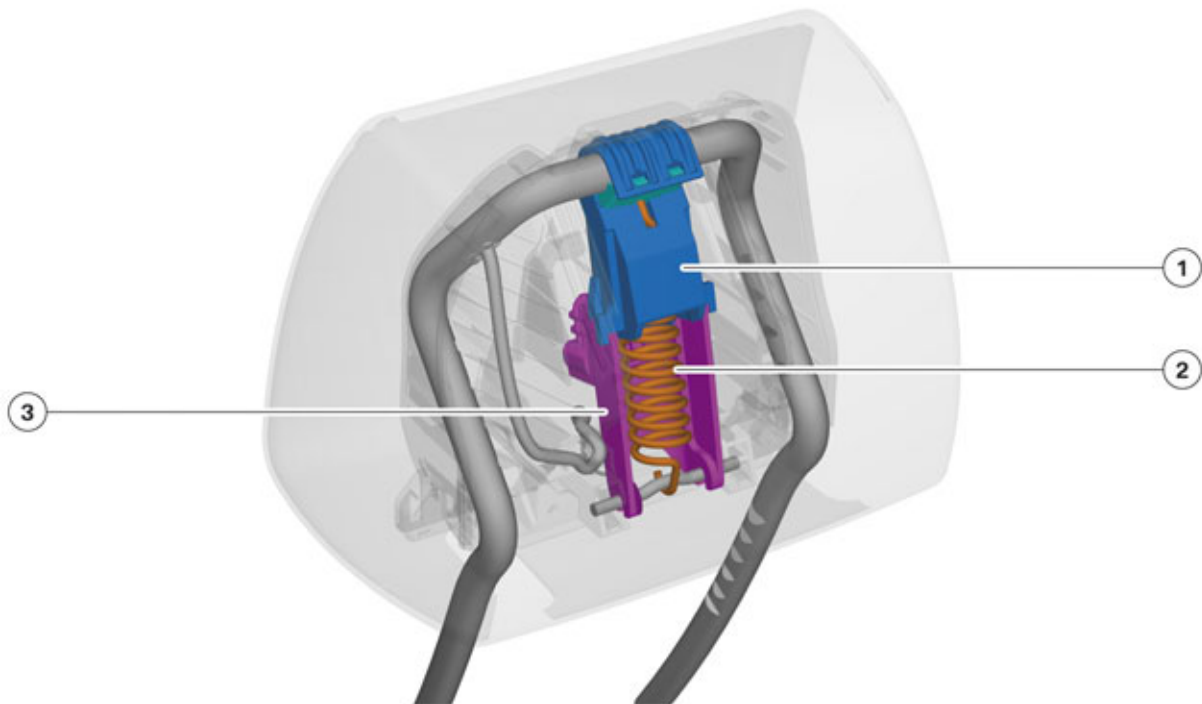

TK10-0832

F25 Crash-active headrests

Index	Explanation
A	Driving position
B	Support activated
C	Crash position
1	Support, upper part
2	Tension spring
3	Support, lower section with pyrotechnics

F25 Passive Safety Systems

5. System Components

The crash-active headrest reduces the load in the cervical vertebrae in the event of a rear-end collision. For the vehicle occupants therefore, correct adjustment of the head restraint and the distance of the head from the head restraint is of crucial importance.

In the event of a rear-end collision, the crash-active headrest reduces the distance between the head and the head restraint before the occupants are displaced backwards. This reduces the danger of injury to the cervical vertebrae, even if a minor accident occurs.



If the crash-active headrests have been triggered, the pyrotechnic actuators must be replaced in the workshop. In this case please always refer to the repair instructions.



Seat or head restraint covers and/or accessories that could impair the protective effect must not be mounted on the head restraints.

5.3.8. Safety battery terminal

The safety battery terminal is triggered at different thresholds when the Crash Safety Module detects a front-end, side-on or rear-end crash of sufficient severity. The connection line between the battery and starter motor/alternator and positive battery connection point is then severed by means of pyrotechnics. The safety battery terminal is located directly at the positive terminal of the battery.

Even though the safety battery terminal has been explosively severed, a voltage supply to all safety-relevant consumers such as hazard warning flashers, interior light and telephone is still ensured.

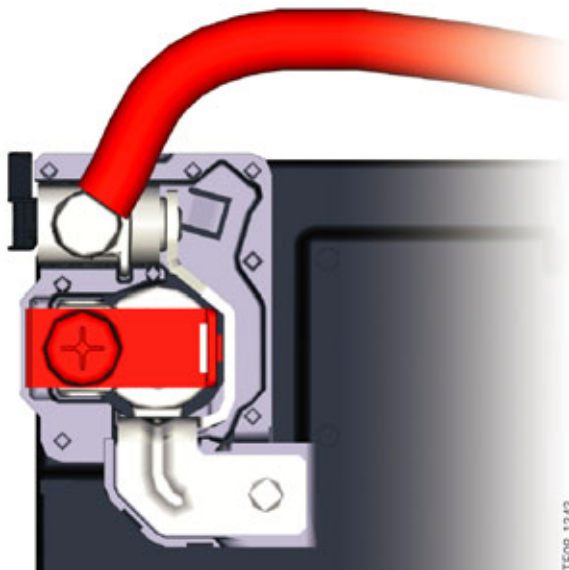

F25 Safety battery terminal

TE08-1343

F25 Passive Safety Systems

5. System Components

5.3.9. Airbag indicator light

The airbag indicator light is located on the instrument panel. The airbag indicator light lights up then goes out during the pre-drive check to signal readiness of the Crash Safety Module and passive safety systems. The airbag indicator light is controlled via a message on the PT-CAN from the Crash Safety Module to the instrument panel. The instrument panel receives a message cyclically. If the message remains off, the airbag indicator light is activated.



F25 Airbag indicator light (example shows high version of instrument panel)

5.3.10. Seat belt warning light

A visual and audible warning is issued if the seat belt is not fastened or is unbuckled when the vehicle is in motion.



F25 Seat belt warning light (example shows high version of instrument panel)

5.3.11. Indicator lamp for front passenger airbag deactivation

The indicator lamp for front passenger airbag deactivation in the F25 is in the roof function center. The indicator lamp for front passenger airbag deactivation is activated if the CIS mat detects a small child in a child seat or if the front passenger seat is not occupied.

F25 Passive Safety Systems

5. System Components

The brightness of the indicator lamp for front passenger airbag deactivation is controlled via the automatic brightness control of the display illumination.



F25 Roof function center with indicator lamp for front passenger airbag deactivation



Bayerische Motorenwerke Aktiengesellschaft
Händlerqualifizierung und Training
Röntgenstraße 7
85716 Unterschleißheim, Germany