

Technical training.
Product information.

F31 Complete Vehicle



BMW Service

Edited for the U.S. market by:
BMW Group University
Technical Training

ST1301

8/1/2013

General information

Symbols used

The following symbol/schematic diagram is used in this document to facilitate better comprehension or to draw attention to very important information:



Contains important safety information and information that needs to be observed strictly in order to guarantee the smooth operation of the system.

Information status and national-market versions

BMW Group vehicles meet the requirements of the highest safety and quality standards. Changes in requirements for environmental protection, customer benefits and design render necessary continuous development of systems and components. Consequently, there may be discrepancies between the contents of this document and the vehicles available in the training course.

This document basically relates to the European version of left-hand drive vehicles. Some operating elements or components are arranged differently in right-hand drive vehicles than shown in the graphics in this document. Further deviations may arise as a result of the equipment specification in specific markets or countries.

Additional sources of information

Further information on the individual topics can be found in the following:

- Operator's manual
- Integrated Service Technical Application.

Contact: conceptinfo@bmw.de

©2012 BMW AG, Munich, Germany

Reprints of this publication or its parts require the written approval of BMW AG, Munich

The information contained in this document forms an integral element of the technical training of the BMW Group and is intended for the trainer and participants in the seminar. Refer to the current respective information systems of the BMW Group for any changes/additions to the specifications.

Information status: **June 2012**
BV-72/Technical Training

F31 Complete Vehicle

Contents

1. Introduction.....	1
1.1. Models.....	1
1.2. History.....	1
1.3. New technical features.....	2
1.4. Dimensions.....	3
1.5. Vehicle weights.....	4
1.6. Silhouette comparison.....	4
1.7. Special features.....	5
2. Bodyshell.....	6
2.1. Materials.....	6
2.1.1. Weight proportions.....	7
2.2. Strut concept, underfloor.....	8
3. Tailgate.....	9
3.1. Power tailgate.....	10
3.1.1. Hands-free tailgate opening.....	10
3.1.2. System wiring diagram.....	11
4. Exterior Trim.....	13
4.1. Roof rails.....	13
4.2. Panorama glass roof.....	13
4.2.1. Dimensions.....	14
5. Interior Equipment.....	15
5.1. Dimensions.....	15
5.2. Material and color concept.....	15
5.3. Rear seats.....	16
6. Luggage Compartment.....	17
7. Automatic Start/Stop Function (MSA).....	18
7.1. System wiring diagram.....	19
7.2. Automatic mode.....	20
7.3. Switch-off inhibitor, switch-on requests, deactivators.....	21
7.3.1. Switch-off inhibitors.....	21
7.3.2. Switch-on requests.....	22
7.3.3. Deactivator.....	22
7.4. Information for service.....	23
7.4.1. Protection against automatic engine start.....	23
7.4.2. Automatic start/stop function checklist for acceptance by the customer.....	24

F31 Complete Vehicle

Contents

7.4.3.	Automatic deactivation of terminal 15.....	26
7.4.4.	Power management and battery replacement.....	26
8.	General Vehicle Electronics	27
8.1.	Bus overview.....	27
8.2.	Exterior lights.....	30
8.3.	Head-Up Display.....	30
9.	Radio and Headunits.....	31
9.1.	Overview of headunits F31.....	31
9.2.	Basic headunit.....	31
9.3.	Headunit High.....	32
10.	Antenna Systems.....	33
10.1.	System wiring diagram.....	36
11.	BMW ConnectedDrive.....	38
11.1.	BMW Apps.....	38
11.1.1.	ECO PRO analyzer.....	38
11.1.2.	Stitcher.....	39
11.1.3.	Wiki Local.....	39

F31 Complete Vehicle

1. Introduction

Following the introduction of the new compact sedan in the BMW 3-Series in February 2012 comes the fifth generation of the Sport Wagon, the F31, in early 2013.

Each generation of these vehicles combined exceptional sporting character and dynamics, maximum comfort and innovation - each using the technology available at the time.



BMW F31

The characteristic BMW proportions, the short overhang at the front, the long wheel base and the extended engine compartment lid transmit a dynamic image, even when the vehicle is stationary.

The formidable efficiency of BMW engines is already known from the F30. The engines are characterized by high power and low consumption at the same time.

Similar to the F30, different equipment packages are also offered in the F31, each with their own individual character.

1.1. Models

The following F31 model will arrive in dealer showrooms in early 2013:

Model	Engine	Power output [kW (HP)]	Torque [Nm (Ft-Lbs)]	Displacement [cm ³]
BMW 328i xDrive Sport Wagon	N20B2000	180 (240)	350 (258)	1997
BMW 328d xDrive Sport Wagon	N47D2001	135 (181)	380 (280)	1995

1.2. History

The first BMW 3-Series Sport Wagon was introduced, to Europe, in 1987. Release in the U.S. did not come until 2001 with the production of the E46/3. In the following table you will see during what years which vehicle generation was sold.

F31 Complete Vehicle

1. Introduction



TG12-0570

BMW 3-Series Sport Wagon – History

Index	Model	Sales period
A	E30/5	from 1987 to 1994 (not US)
B	E36/3	from 1995 to 1999 (not US)
C	E46/3	from 1998 to 2005
D	E91	from 2005 to 2012
E	F31	from 2012

1.3. New technical features

Of the many components which have been altered or newly developed, the following must be mentioned:

- Reinforcements, vehicle underbody
- Tailgate
- Rear seat backrest
- Headunit High

F31 Complete Vehicle

1. Introduction

1.4. Dimensions

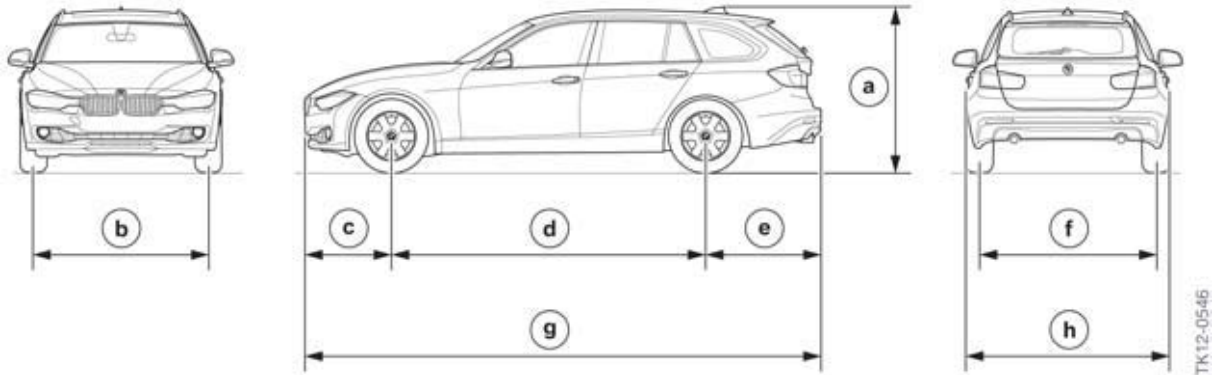

F31 overall dimensions

Index	Explanation		F31	E91
a	Vehicle height, empty	[mm]	1429	1418
b	Front track width, basic wheels	[mm]	1543 ¹	1506
c	Front overhang	[mm]	776	757
d	Wheel base	[mm]	2810	2760
e	Rear overhang	[mm]	1038	1010
f	Rear track width, basic wheels	[mm]	1583 ²	1535
g	Vehicle length	[mm]	4624	4537
h	Vehicle width excluding outside mirrors (vehicle width with outside mirror)	[mm]	1811 (2031)	1817 (1989)

¹ BMW 328i Sedan: 1531 mm.

² BMW 328i Sedan: 1572 mm.

In the case of vehicle curb weight the F31 has a turning circle of 11.3 m (E91: 11.0 m).

F31 Complete Vehicle

1. Introduction

1.5. Vehicle weights

Vehicle curb weights listed in the US market for the F31 and the E91 versions are set out in the following table.

Model (BMW 328i xDrive Sport Wagon)	Measured Units	Curb weight (US) (automatic transmission)
F31	kg/ lbs	1715/3780
E91	kg/ lbs	1710/3770

The F31 will only be available in the U.S. market with xDrive and automatic transmission.

By shifting the front axle 10 mm to the front, while retaining the engine mount, an even more reasonable axle-load distribution was able to be achieved in comparison to the predecessor.

1.6. Silhouette comparison

F31
E91

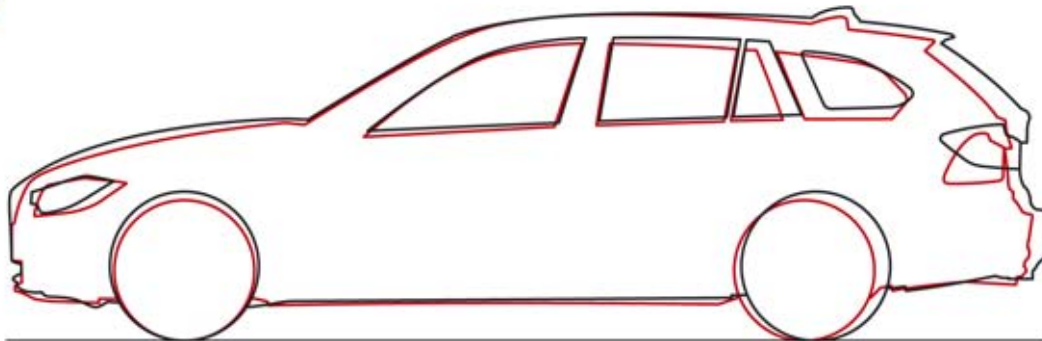

TK12-0547

F31 Silhouette comparison with BMW E91

		F31	E91
Vehicle height, empty	[mm]	1429	1418
Front overhang	[mm]	776	757
Wheel base	[mm]	2810	2760
Rear overhang	[mm]	1038	1010
Vehicle length	[mm]	4624	4537

The F31 has a higher roofline in the rear area, a flatter rear window, as well as a longer overhang at the rear, in comparison to the predecessor.

F31 Complete Vehicle

1. Introduction

1.7. Special features

Some of the features of the F31 are listed below:

- Engine with exhaust turbocharger
- Gasoline engine with Turbo-Valvetronic Direct Injection (TVDI) and BMW TwinPower Turbo
- Automatic start/stop function (MSA)
- Electronic Power Steering (EPS)*
- Increase of front track width by 37 mm compared to predecessor
- Improved driving dynamics thanks to significantly increased rigidity of the front carriage
- Reasonable axle-load distribution thanks to forward shift of front axle by 10 mm while retaining the engine mount
- Improved entrance in the rear passenger compartment
- Optional variable sports steering
- Optional Adaptive M Suspension (2VF)
- Optional Adaptive Headlight and High-beam Assistant
- Increase of the maximum possible desired speed of the active cruise control ACC to 210 km/h (130 mph)

* Electronic Power Steering is used for the first time in conjunction with xDrive on a sedan.

F31 Complete Vehicle

2. Bodyshell

2.1. Materials

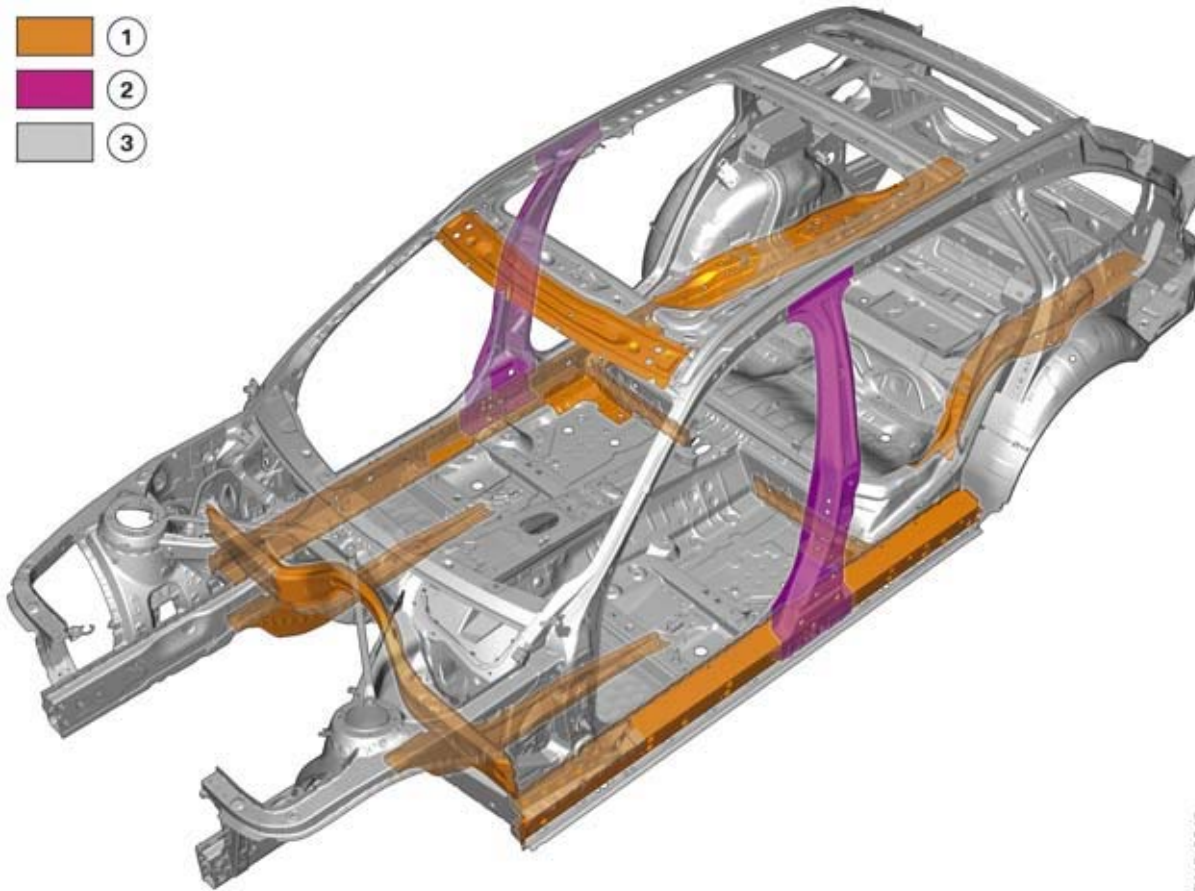
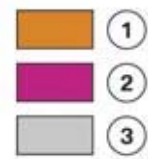

TK12-0549

F31 material grades for bodyshell

Index	Explanation
1	Multi-phase steels (> 300 MPa)
2	Hot-formed steels (> 900 MPa)
3	Other steels (< 300 MPa)

Multi-phase steels are steels where the structure consists of a number of phases. Higher-strength multi-phase steels with a yield strength $R_{p0.2}$ of 300 to 600 MPa are, for example, dual-phase steels or TRIP steels. Super-strength multi-phase steels with a yield strength $R_{p0.2}$ in excess of 600 MPa are, for example, complex-phase steels or martensitic-phase steels.

Hot-formed manganese-boron steels are super-strength steels with a yield strength $R_{p0.2}$ in excess of 900 MPa.

F31 Complete Vehicle

2. Bodyshell

2.1.1. Weight proportions

To reduce the vehicle weight and still guarantee maximum stability of the bodyshell, high-strength and super-strength multi-phase steels are used, among other things. In comparison to the predecessor, super-strength, hot-formed steels are also used.

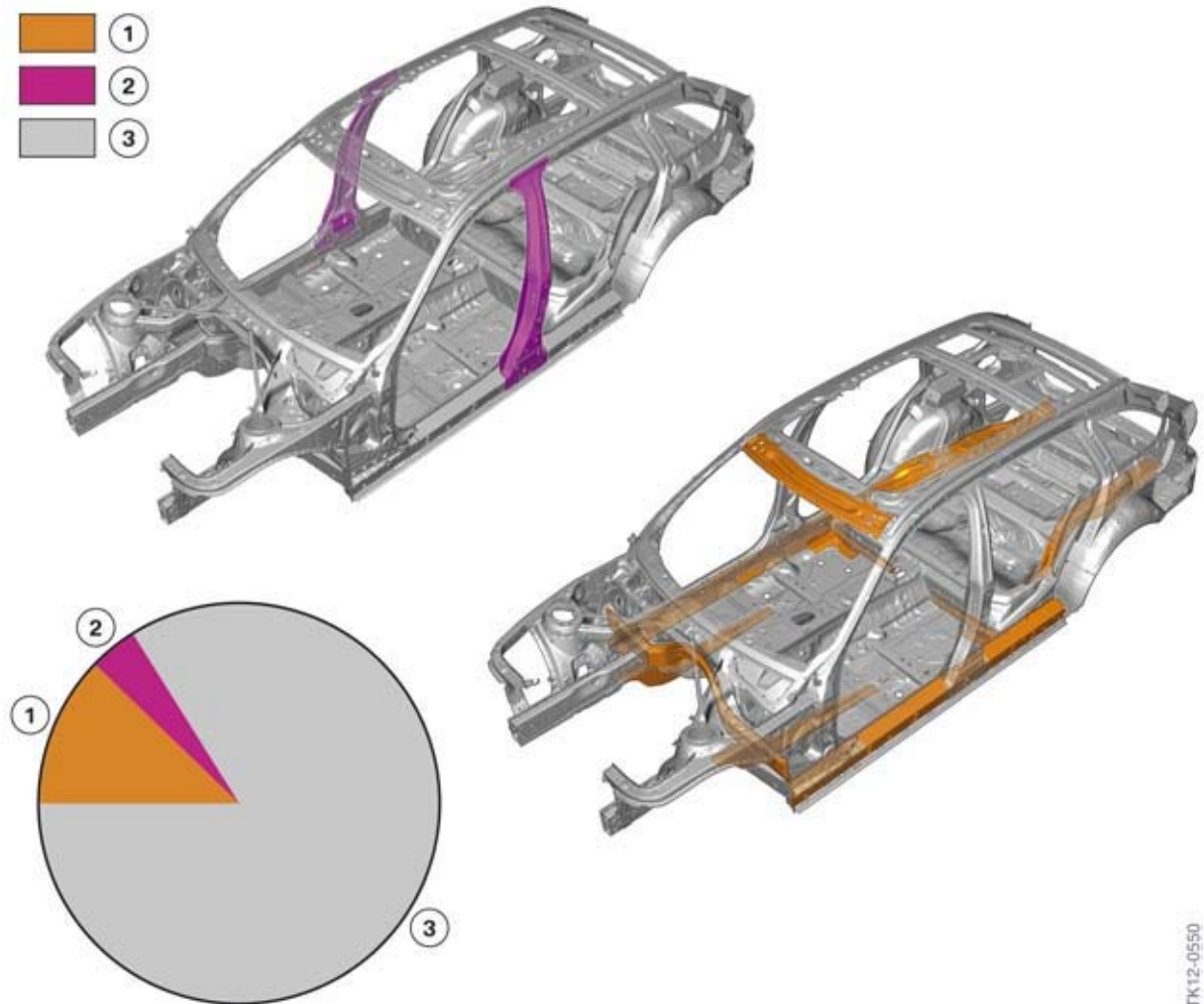

F31 bodyshell, distribution of material grades

TK12-0550

Index	Explanation
1	Multi-phase steels (> 300 MPa), 12 % of the body weight
2	Hot-formed steels (> 900 MPa), 4 % of the body weight
3	Other steels (< 300 MPa), 84 % of the body weight

F31 Complete Vehicle

2. Bodyshell

2.2. Strut concept, underfloor

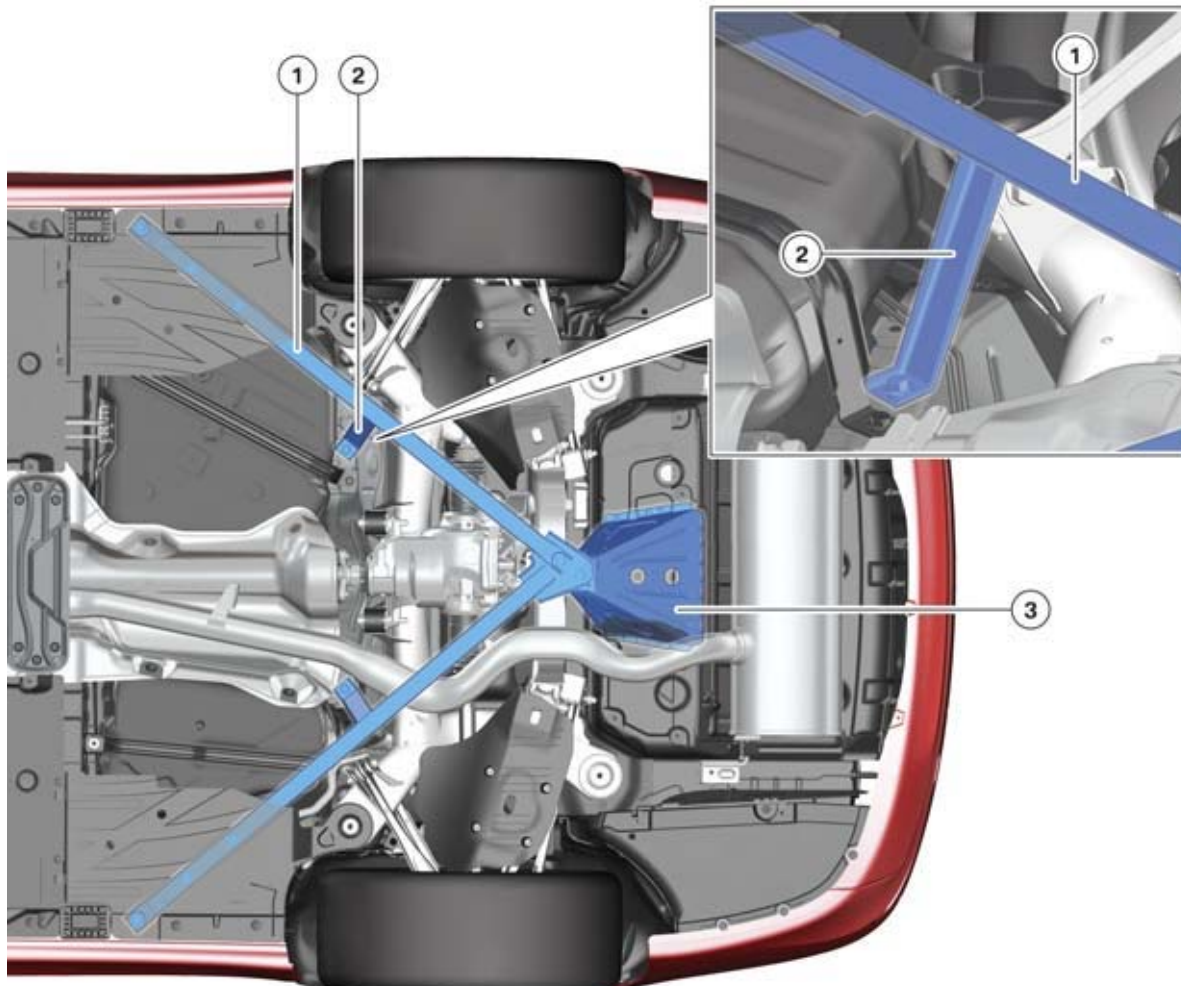

TK12-0551

F31 Strut concept, underfloor

Index	Explanation
1	Reinforcement strut
2	Support rod
3	Support stand

To increase the vehicle rigidity two reinforcement struts are installed at the vehicle underbody, which are secured at the side to the frame rail and at the rear to the also new support stand. The support stand is welded to the luggage compartment well which has a slightly thicker wall thickness in comparison to the F30.

F31 Complete Vehicle

3. Tailgate



F31 tailgate

Index	Explanation
1	Tailgate lock
2	Ground lights
3	Spindle drive

The tailgate lock actuator is located under the luggage compartment floor in the F31. The relevant retaining hook is installed in the tailgate.

The additional ground lights inside the handle recesses of the tailgate are also new. They illuminate the loading edge and the floor behind the vehicle so that one can see where they are stepping.

F31 Complete Vehicle

3. Tailgate

3.1. Power tailgate

For the first time in the BMW 3-Series a power tailgate is installed as standard. As is known from other BMW models, the tailgate is opened or closed by electric spindle drives in the water channel.

Two hall effect sensors are installed in the spindle drives to detect the position of the tailgate. These are read out from the control unit for the power tailgate.

The tailgate opens automatically when it is actuated by one of the following buttons:

- Button for the remote control or ID transmitter
- Button on the tailgate, outer
- Button on the A-post

In conjunction with the optional equipment Comfort Access (option 322) the tailgate can also be actuated hands-free by means of targeted foot movement.

Using the iDrive controller, how far the tailgate should open can be set.

The tailgate closes automatically if it is actuated via the button on the inside of the tailgate.

3.1.1. Hands-free tailgate opening

The hands-free tailgate opening is installed in vehicles with optional equipment Comfort Access (option 322). It is another operating element for the tailgate by the customer. Two sensors under the rear bumper detect the movement of the customers foot by making a simple kicking motion. The top sensor detects the shin while the bottom detects the toes.

For more information refer to ST1113 F30 Complete Vehicle: General Vehicle Electronics

F31 Complete Vehicle

3. Tailgate

3.1.2. System wiring diagram

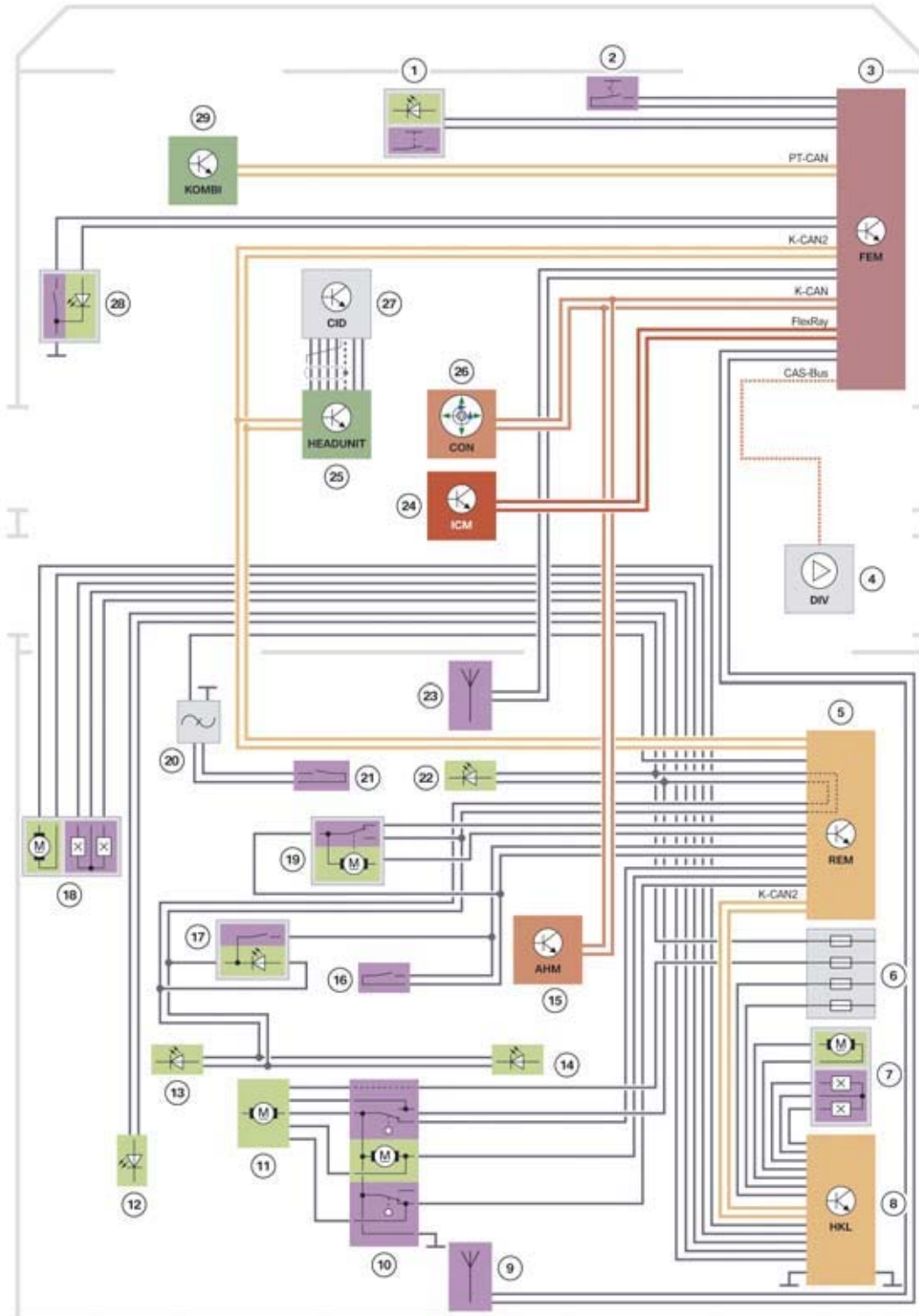

F31 Automatic rear lid actuation

TE12-0561

F31 Complete Vehicle

3. Tailgate

Index	Explanation
1	Button for central locking system/hazard warning switch
2	Hotel position switch
3	Front Electronic Module (FEM)
4	Antenna diversity with remote control receiver (FBD)
5	Rear Electronic Module (REM)
6	Power distribution box, luggage compartment
7	Engine spindle drive, right
8	Control unit for power tailgate (HKL)
9	Bumper antenna, Comfort Access
10	Door lock, tailgate
11	Automatic Soft Close system, tailgate
12	Luggage compartment light*
13	Tailgate light*
14	Tailgate light (discontinued depending on vehicle equipment)
15	(not US)
16	External tailgate button
17	Internal tailgate push-button
18	Engine spindle drive, left
19	Door lock, rear window
20	Interference suppression filter
21	Button, rear window
22	Luggage compartment light*
23	Luggage compartment antenna, Comfort Access
24	Integrated Chassis Management (ICM)
25	Headunit
26	Controller
27	Central information display (CID)
28	Tailgate push-button on the A-post
29	Instrument cluster (KOMBI)

* depending on vehicle equipment designed as LED or bulb.

F31 Complete Vehicle

4. Exterior Trim

4.1. Roof rails



F31 roof rails

The roof rails are designed to optimally fit the outer contour of the vehicle. They are available as an option in either black or Aluminum Satin.

4.2. Panorama glass roof



F31 panoramic glass sunroof

TK12-0560

F31 Complete Vehicle

4. Exterior Trim

Index	Explanation
1	Glass sunroof
2	Fixed glass element
3	Frame with motors for glass sunroof and sliding head liners
4	Sliding head liner, rear
5	Sliding head liner, front
6	Wind deflector

A two-piece panorama glass roof is now standard equipment for the F31 in the US market. The larger area of glass gives the interior a light and roomy feel while providing the passengers with a sense of spaciousness.

The panoramic glass roof is a slide / tilt sunroof that runs inwards, the same as that of the F25. The glass sunroof and the sliding head liner are fully electric and are operated by means of a switch on the roof function center (FZD).

To exclude the risk of possible injury an anti-trap mechanism, for the glass sunroof and the sliding head liners, is active over the entire range of travel. The anti-trapping feature complies with all international legal requirements.

4.2.1. Dimensions

Dimensions

- Glass sunroof, length: 472 mm
- Glass sunroof, width: 847 mm
- Fixed glass element, length: 500 mm

Opening width

- Glass sunroof fully opened: 464 mm
- Sliding head liner fully opened: 858 mm
- Glass sunroof ventilation gap: 43.5 mm

F31 Complete Vehicle

5. Interior Equipment

5.1. Dimensions

Above all, the headroom and legroom in the rear passenger compartment have been increased in the F31.

		F31	E91
Shoulder room, front	[mm]	1400	1408
Shoulder room, rear	[mm]	1400	1400
Elbow room, front	[mm]	1451	1459
Elbow room, rear	[mm]	1460	1455
Maximum headroom, front	[mm]	1026	978
Maximum headroom, rear	[mm]	973	964
Front legroom	[mm]	1068	1054
Rear legroom	[mm]	888	874
Luggage compartment capacity	[liters]	495	460

5.2. Material and color concept

In addition to the comprehensive offering of optional equipment, the F31 can also be individualized with the following equipment packages:

- BMW Sport Line (ZSL)
- BMW Modern Line (ZML)
- BMW Luxury Line (ZLL)
- BMW M Sport Line (ZMM)

The equipment packages contain both general optional equipment and line-specific features.

The content of the equipment packages is partly binding. Individual elements cannot be deselected, creating an excellent price/performance ratio.

F31 Complete Vehicle

5. Interior Equipment

5.3. Rear seats



F31 through-loading system

The rear seat backrest can be divided into the ratio 40/20/40. The three sections can be folded down either individually or together in order to achieve a total luggage compartment capacity of 1500 liters.

F31 Complete Vehicle

6. Luggage Compartment



F31 luggage compartment

Special features

- Luggage compartment capacity up to approx. 35 liters larger than predecessor
- Enlarged loading opening in width and height
- Level luggage compartment floor with flowing transition to the side panel
- Roller cover for luggage compartment disconnected from the load area net
- Roller cover for luggage compartment can be stowed under additional flap under the luggage compartment floor
- Luggage compartment can also be protected with the load area net when the backrest is folded down
- Cover, loading edge with stainless steel insert
- Even, stable areas at the side and flap at the left with access to the DVD changer
- 12 V power socket, left
- Two bag hooks integrated in the luggage compartment trim panel
- Tie-down by four lashing eyes
- Luggage compartment net and tensioning strap on the right luggage compartment trim panel

F31 Complete Vehicle

7. Automatic Start/Stop Function (MSA)

The automatic start/stop function (MSA) comes standard in the F31. The operation is similar to current BMW models, but overall comfort of the function is improved.

The following measures were taken to improve performance:

- Immediately, before the engine automatically shuts down, the drivetrain is relieved of the alternator and air conditioning compressor loads thus reducing drive belt tension. Vibration is minimized and results in a smoother engine shutdown.
- Noises during automatic engine starting are significantly reduced by earlier disengagement of the starter motor. The starter motor is now disengaged when a safe combustion process is reached instead of release at idle speed, as before. This is identified by the Digital Engine Electronics (DME) or Digital Diesel Electronics (DDE).
- Consistent automatic start/stop functionality is improved by:
 - elimination of the outside temperature threshold of 3 °C (37 °F) (switch-off inhibitor)
 - decreasing the reactivation speed to 5 km/h (3 mph) (switch-off inhibitor)
 - elimination of time restrictions of automatic engine stops for some selected switch-off inhibitors.

If the automatic start/stop function for the engine is not available due to a switch-off inhibitor, this is displayed on the instrument cluster. The vehicle must be at a standstill for this. The display is delayed by one second.

The following switch-off inhibitors are exceptions:

- The engine is not running at idle speed
- The steering wheel movement is not yet completed (steering wheel angle however < 90°)
- The brake pedal is not pressed firmly enough

An indicator also appears in the Central Information Display, when in the EfficientDynamics menu, with information on the relevant switch-off inhibitor. If the driver suppresses an automatic engine shutdown, the selector lever position is in drive position S/M, the display does not appear.

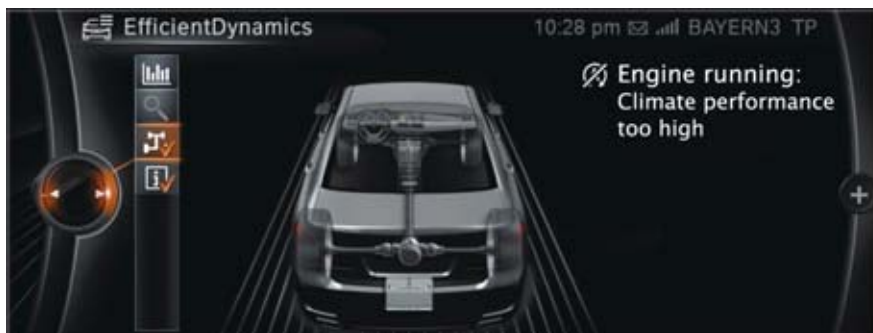

F31 technology experience monitor (HU-H)

F31 Complete Vehicle

7. Automatic Start/Stop Function (MSA)

7.1. System wiring diagram

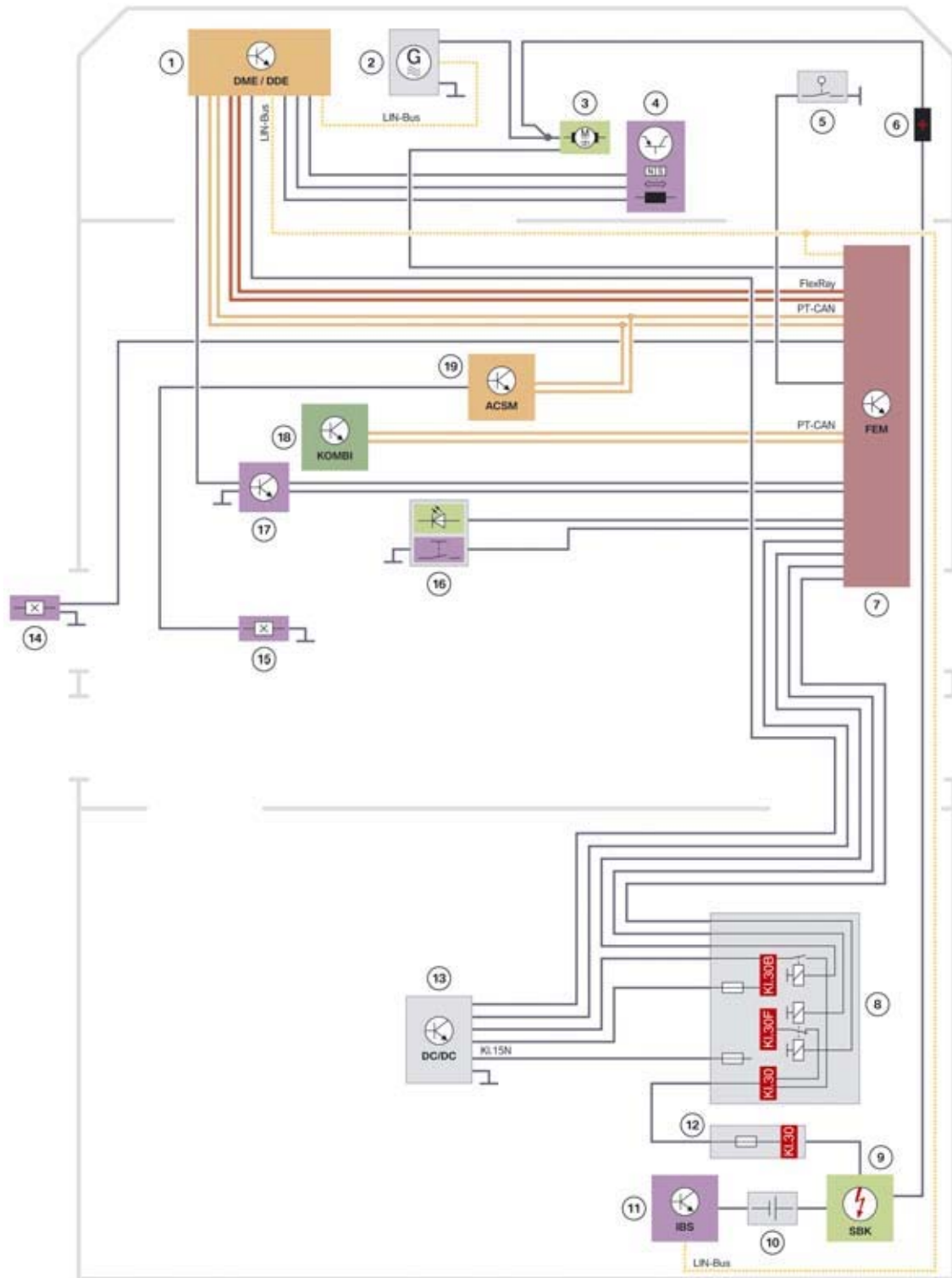

F31 wiring diagram, automatic start/stop function

TE12-0553

F31 Complete Vehicle

7. Automatic Start/Stop Function (MSA)

Index	Explanation
1	Digital Engine Electronics (DME); Digital Diesel Electronics (DDE)
2	Alternator
3	Starter motor
4	(not US)
5	Engine compartment lid contact switch
6	B+ jump start terminal point
7	Front Electronic Module (FEM)
8	Power distribution box, luggage compartment
9	Safety battery terminal (SBK)
10	Battery
11	Intelligent battery sensor (IBS)
12	Battery power distribution box
13	DC/DC converter
14	Door contact, front driver's side
15	Seat belt buckle switch, driver
16	START/STOP button
17	(not US)
18	Instrument cluster (KOMBI)
19	Crash Safety Module (ACSM)

7.2. Automatic mode

The automatic start/stop function is ready for operation following every engine start.

The automatic start/stop function is activated at road speeds of > 5km/h (3 mph).

The driver's absence is detected via the seat belt buckle switch and via the door contact.

When the driver leaves the vehicle, the automatic start/stop function is deactivated to prevent the engine from starting automatically.

The automatic start/stop function is always reactivated if:

- the driver's seat belt is fastened and the vehicle is travelling at a speed of > 5 km/h (3 mph)
- the driver's door is closed and the vehicle is travelling at a speed of > 5 km/h (3 mph).

The prerequisites for deactivation of the automatic start/stop function vary depending on which switching mode the seat belt buckle switch and door contact are in when the automatic start/stop function is activated:

F31 Complete Vehicle

7. Automatic Start/Stop Function (MSA)

Status during activation of automatic start/stop function	Prerequisites for deactivation of automatic start/stop function
<ul style="list-style-type: none">The driver's seat belt is fastenedThe driver's door is closed	The driver unfastens the seat belt buckle and opens the driver's door
<ul style="list-style-type: none">The driver's seat belt is not fastenedThe driver's door is closed	The driver opens the driver's door
<ul style="list-style-type: none">The driver's seat belt is fastenedThe driver's door is opened	The driver unfastens the seat belt buckle

The automatic start/stop function is reactivated if:

- the seat belt buckle is fastened and/or the driver's door is closed and the engine is started
- the seat belt buckle is fastened and/or the driver's door is closed and the vehicle is travelling at a speed of > 5 km/h (3 mph).

7.3. Switch-off inhibitor, switch-on requests, deactivators

7.3.1. Switch-off inhibitors

Under certain conditions, it is necessary to suppress the automatic start/stop function if:

- the brake pedal is not pressed firmly enough which means the vehicle is detected as not being held sufficiently
- the vehicle stops on uphill/downhill gradients > 12%
- the steering angle is > 6°
- the steering wheel movement is not yet complete (as otherwise sufficient support would not be provided by the power steering as a consequence)
- the vehicle was not driven at a speed of > 5 km/h (3 mph) following the previous engine shutdown
- the engine is not running at idle speed (accelerator pedal is being pressed)
- the vehicle is reversing
- the operating temperature of the engine is too low
- the active carbon filter is being flushed (gasoline engines only)
- the diesel particulate filter is being regenerated
- the fuel grade is insufficient
- the transmission adaptation is active
- the hydraulic impulse storage is not yet charged (holds hydraulic pressure in transmission)
- Stop-and-go traffic

F31 Complete Vehicle

7. Automatic Start/Stop Function (MSA)

- the state of charge is too low
- the ambient temperature is above +30°C (86 °F) (with heating and air conditioning system switched on)
- the condensation sensor of the IHKA detects fogging of the windshield
- the heating and air conditioning system is switched on but the passenger compartment has not yet heated up or cooled down to the required temperature
- ABS braking has been applied.

7.3.2. Switch-on requests

Conversely, it may also be necessary to start the engine if:

- the vehicle is not sufficiently held by the released brake pedal
- the steering wheel is moved
- the accelerator pedal is actuated
- the transmission switches from "P" to "D"; the driver previously shifted from position "D" to "P" when the engine was automatically shut down so he could take his foot off the brake pedal
- the transmission changes from "D" to "N" or "R"
- the state of charge is too low
- the ambient temperature is above +30°C (86 °F) (with heating and air conditioning system switched on)
- the condensation sensor of the IHKA detects fogging of the windshield
- the evaporator temperature is too low to ensure sufficient climate control
- Special case: the driver's seat belt is still fastened, the driver's door is opened and the brake pedal is released
- the vehicle rolls (vehicle speed > 5 km/h (3 mph)).

Different input variables are used, for example:

- ambient pressure (by ambient pressure sensor)
- engine speed (by crankshaft sensor)
- force and displacement in the tandem brake master cylinder, determined from brake pressure in the front axle brake circuit (pressure sensor in the DSC).

7.3.3. Deactivator

If a deactivation condition exists, the automatic start/stop function is deactivated.

The following scenarios arise, depending on when the deactivation condition for the automatic start/stop function occurred:

F31 Complete Vehicle

7. Automatic Start/Stop Function (MSA)

- the engine continues running and is no longer stopped automatically
- the engine was stopped automatically and starts once again automatically
- the engine was stopped automatically and no longer starts automatically (the Check Control message "MSA off" appears - the start/stop button must be operated in order to start the engine).

The following deactivators may occur:

- the driver's absence has been detected
- the engine did not start when the ignition was switched on
- the engine compartment lid is unlocked
- a fault related to the automatic start/stop function has been detected at the engine, transmission or components involved in the automatic start/stop function
- the bus communication is faulty
- the automatic start/stop function has been deactivated via the automatic start/stop button
- the automatic start/stop function was deactivated via the diagnosis system
- the vehicle is in transport mode
- the engine was switched off on account of insufficient engine speed

The individual statuses can be read out using the diagnosis system.

An easy-to-follow example of a deactivation with subsequent switch-on request:

- the automatic start/stop function is deactivated via the automatic start/stop button in the automatic engine shutdown phase,
- as a consequence, the engine starts automatically,
- after this, no further automatic engine shutdowns occur, the automatic start/stop function remains deactivated.

7.4. Information for service

7.4.1. Protection against automatic engine start



Observe the safety precautions when carrying out work on vehicles equipped with the automatic start/stop function!

The engine is prevented from starting automatically when work is being carried out in the engine compartment. The automatic start/stop function is deactivated as soon as the engine compartment lid is opened.

The engine can be restarted via the start/stop button.

F31 Complete Vehicle

7. Automatic Start/Stop Function (MSA)

The automatic start/stop function is reactivated if:

- the engine compartment lid is closed and the engine is restarted
- the engine compartment lid is closed and the vehicle is travelling at a speed of > 5 km/h (3 mph).

7.4.2. Automatic start/stop function checklist for acceptance by the customer

In the event of customer complaints, check these against the "Automatic Start/Stop function checklist".

Process any fault entries using the diagnosis system. If no fault entries exist, check the condition of the automatic start/stop function with the automatic start/stop function system check.

The automatic start/stop function system check service function shows an overview of the most recent automatic start/stop function status and provides further assistance with troubleshooting.

Customer complaint: Frequently no engine shutdown - the engine repeatedly does not stop in situations where it should shut down automatically.

Check the general automatic engine shutdown criteria in dialogue with the customer:

	Yes	No
Driver's seat belt fastened?	<input type="checkbox"/>	<input type="checkbox"/>
Vehicle at standstill?	<input type="checkbox"/>	<input type="checkbox"/>
Automatic transmission in position "D", brake pedal pressed?	<input type="checkbox"/>	<input type="checkbox"/>
Engine at operating temperature?	<input type="checkbox"/>	<input type="checkbox"/>
Vehicle not driven backwards before stopping?	<input type="checkbox"/>	<input type="checkbox"/>
Automatic start/stop function activated (automatic start/stop button not operated - LED does not light up)?	<input type="checkbox"/>	<input type="checkbox"/>
State of battery charge OK (no long immobilization periods or excessive short-distance driving)?	<input type="checkbox"/>	<input type="checkbox"/>
Quality level of battery OK (no external charging procedure, no other devices connected to the battery)?	<input type="checkbox"/>	<input type="checkbox"/>

If all criteria have been answered with **Yes**:

- Implement automatic start/stop function system check service function

If at least one criterion has been answered with **No**:

- Automatic start/stop function is in working order

F31 Complete Vehicle

7. Automatic Start/Stop Function (MSA)

Customer complaint: Engine does not shutdown from time to time - the engine sometimes does not stop in situations where it should shut down automatically.

Check whether the automatic function has prevented the engine from being shutdown for safety or comfort reasons. Explain the automatic functions to the customer:

	Yes	No
Heating and air conditioning system switched on and passenger compartment in cooling-down period (e.g. when setting off or following engine shutdown)	<input type="checkbox"/>	<input type="checkbox"/>
Windshield starts to fog up with automatic air conditioning	<input type="checkbox"/>	<input type="checkbox"/>
Steering wheel movements when vehicle is at a standstill	<input type="checkbox"/>	<input type="checkbox"/>
Stop-and-go traffic (at least three stops made in short succession at a speed of < 25 km/h)	<input type="checkbox"/>	<input type="checkbox"/>

If all criteria have been answered with **No**:

- Implement automatic start/stop function system check service function

If at least one criterion has been answered with **Yes**:

- Automatic start/stop function is in working order

Customer complaint: Sudden automatic engine start - the engine unexpectedly starts automatically although no automatic engine start was expected.

Check whether the engine has been automatically started by the automatic function for safety or comfort reasons. Explain the automatic functions to the customer:

	Yes	No
Passenger compartment heating up with heating and air conditioning system switched on	<input type="checkbox"/>	<input type="checkbox"/>
Windshield starts to fog up with automatic air conditioning	<input type="checkbox"/>	<input type="checkbox"/>
Steering wheel movements when vehicle is at a standstill	<input type="checkbox"/>	<input type="checkbox"/>
The vehicle has started moving, speed < 5 km/h (3 mph)	<input type="checkbox"/>	<input type="checkbox"/>
Low brake vacuum due to repeated operation of brake pedal	<input type="checkbox"/>	<input type="checkbox"/>
State of battery charge too low due to extended engine stop phases	<input type="checkbox"/>	<input type="checkbox"/>

If all criteria have been answered with **No**:

- Implement automatic start/stop function system check service function

If at least one criterion has been answered with **Yes**:

- Automatic start/stop function is in working order

F31 Complete Vehicle

7. Automatic Start/Stop Function (MSA)

Customer complaint: Engine not starting - the brake pedal was released but the engine did not start automatically.

	Yes	No
Driver's door opened and seat belt buckle unfastened during the engine stop phase?	<input type="checkbox"/>	<input type="checkbox"/>
Engine compartment lid opened?	<input type="checkbox"/>	<input type="checkbox"/>

If both criteria have been answered with **No**:

- Implement automatic start/stop function system check service function

If at least one criterion has been answered with **Yes**:

- Automatic start/stop function is in working order

7.4.3. Automatic deactivation of terminal 15

Terminal 15 is switched off automatically via the door contact when the driver's door is opened and closed with the engine switched off.

Terminal 15 can be switched back on permanently by subsequently pressing the start/stop button.

7.4.4. Power management and battery replacement

The automatic start/stop function and power management are strongly intertwined.

The data on battery type and state of charge could get lost after:

- Programming of the engine control
- Replacement of the intelligent battery sensor
- Disconnection of the battery
- Battery replacement

This data will only be available again once a standby current measurement has been carried out internally in the vehicle and after it has gone to sleep and has been locked. This measurement takes around 6 hours during which the vehicle must not be woken up. The automatic start/stop function will remain inactive until the data is transferred.

In order for the vehicle to register the battery data after the battery has been replaced, the internal standby current must be measured.

If the battery is replaced, an AGM battery must be reinstalled to ensure the automatic start/stop function remains in proper working order.

F31 Complete Vehicle

8. General Vehicle Electronics

8.1. Bus overview

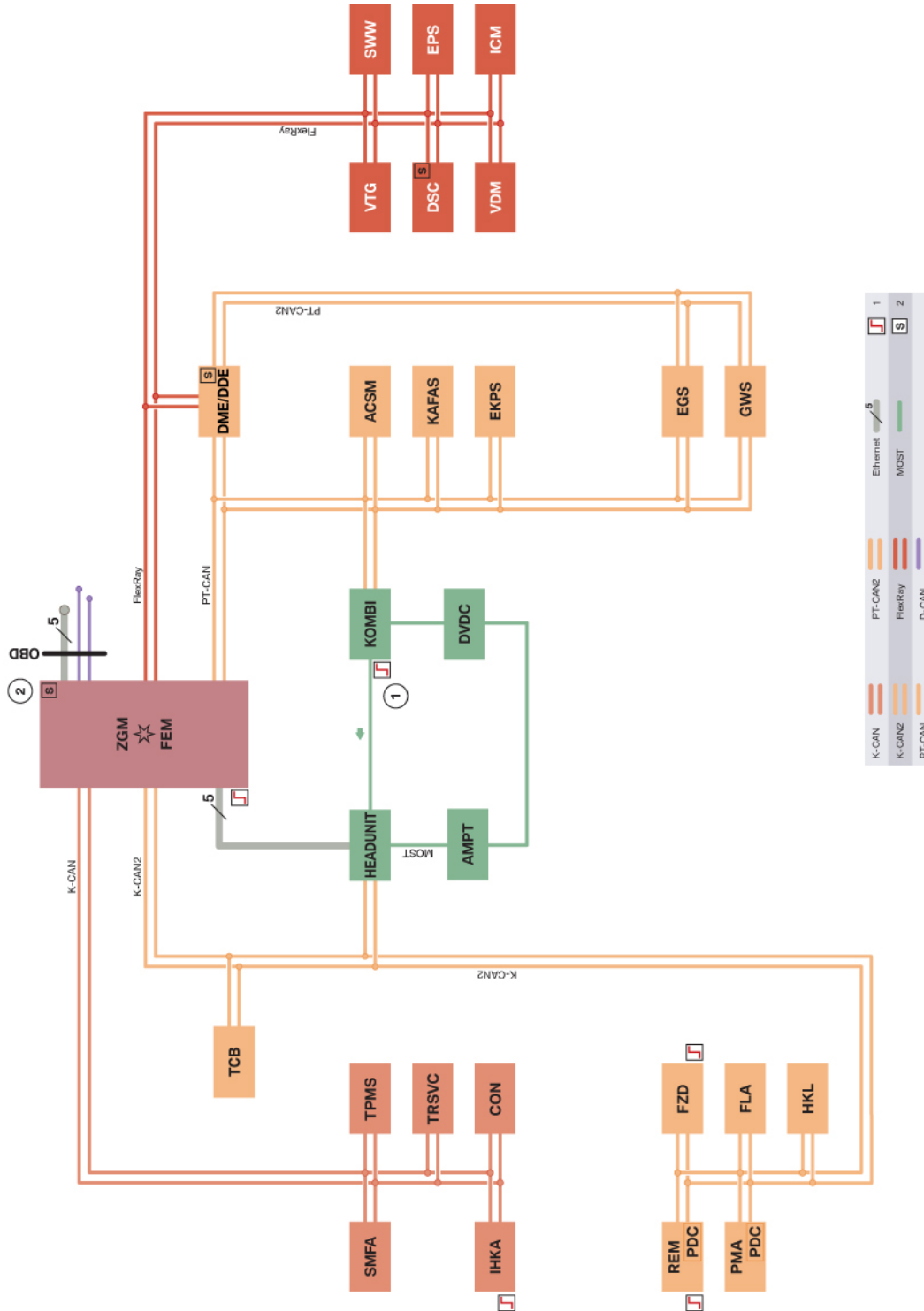

F31 Bus overview

TE12-0562_2

F31 Complete Vehicle

8. General Vehicle Electronics

Index	Explanation
1	Control units authorized to perform wake-up function
2	Start-up node control units for starting and synchronizing the FlexRay bus system
ACSM	Advanced Crash Safety Module (ACSM)
AMPT	Top HiFi amplifier
CON	Controller
D-CAN	Diagnosis-on-Controller Area Network
DDE	Digital Diesel Electronics
DME	Digital Engine Electronics
DSC	Dynamic Stability Control
DVDC	DVD changer
EGS	Electronic transmission control
EKPS	Electronic fuel pump control
EPS	Electronic Power Steering (electromechanical power steering)
Ethernet	Cable-based data network technology for local data networks
FEM	Front Electronic Module
FLA	High-beam assistant
FlexRay	Fast, preset and fault-tolerant bus system for use in automotive sector
FZD	Roof function center
GWS	Gear selector switch
HEADUNIT	Headunit (Basic, or Headunit-High)
HKL	Automatic tailgate actuation
ICM	Integrated Chassis Management
IHKA	Integrated automatic heating / air conditioning system
K-CAN	Body controller area network
K-CAN2	Body controller area network 2
KAFAS	Camera-based driver support systems
KOMBI	Instrument cluster (MOST only with option 6WA, instrument cluster with extended scopes)
MOST	Media Oriented System Transport
OBD	On-board diagnosis (diagnostic socket)
PDC	Park Distance Control (with option 5DP, Parking Maneuvering Assistant: integrated in the Parking Maneuvering Assistant control unit, otherwise integrated in the Rear Electronic Module control unit)
PMA	Parking Maneuvering Assistant
PT-CAN	Powertrain controller area network

F31 Complete Vehicle

8. General Vehicle Electronics

Index	Explanation
PT-CAN2	Powertrain controller area network 2
TCB	Telematic Communication Box (replaced the Combox telematics) ¹
TPMS	Tire pressure monitoring system
REM	Rear Electronic Module
SMFA	Driver's seat module
SWW	Lane change warning
TRSVC	Control unit for all-round vision camera
VDM	Vertical Dynamics Management
ZGM	Central gateway module

¹ Only for vehicles with Headunit High (HU-H)

F31 Complete Vehicle

8. General Vehicle Electronics

8.2. Exterior lights

The exterior lights of the F31 are based on the current BMW F30 models.

The F31 is equipped with halogen headlights as standard. Bi-xenon headlights (option 522) are offered as optional equipment.

With halogen headlights, the headlight beams are regulated manually.

With the optional equipment, bi-xenon headlight, LEDs are used for the daytime running lights, parking lights and positioning lights.

The Adaptive Headlight is available as an element of the optional equipment Lighting Package (option ZPL). It is only offered in conjunction with bi-xenon headlights.

8.3. Head-Up Display



F31 entertainment list in the Head-Up Display

Head-Up Display is available as an option in the F31. As well as incoming calls, entertainment and telephone lists can now be displayed. Depending on the drivers preference they can be set to display on the HUD or as before on the instrument cluster. Selection of displays can be controlled using the switch block on the steering wheel, or for vehicles with HU-H, the iDrive controller.

F31 Complete Vehicle

9. Radio and Headunits

9.1. Overview of headunits F31

Optional equipment	Headunit	CID	Controller	Navigation
Radio Professional (standard)	Basic headunit	6.5"	5-button	No
Professional navigation (option 609)	Headunit High (HU-H)	8.8"	7-button	Yes

9.2. Basic headunit



F31 Basic headunit

Index	Explanation
1	CID
2	Audio system operation unit
3	Basic headunit
4	Controller

The Basic headunit (HU-B) is installed as standard equipment.

The Basic headunit comes with a central information display (CID) with 6.5" screen.

F31 Complete Vehicle

9. Radio and Headunits

9.3. Headunit High



F31 Front view of Headunit High with DVD drive

Index	Explanation
1	DVD drive
2	Housing of Headunit High

The new HU-H is the successor to the previously used Car Information Computer (CIC). Information on the Headunit High can be found in the product information bulletin "Headunit High".

The telephone and multimedia functions are integrated in the Headunit High. A Combox is no longer required with the Headunit High. For telematics functions the new control unit Telematic Communication Box (TCB) is installed. Information on this can also be found in the Headunit High Training Reference manual ST1211.

F31 Complete Vehicle

10. Antenna Systems

The F31 has different antenna systems, depending on the national-market version and optional equipment used:

Antenna	System	Location
FM antenna	Radio	Rear window
AM antenna	Radio	Rear spoiler
SDARS antenna	Radio	Roof
GPS antenna	Navigation system or TCB	Roof antenna
Remote control service antenna	CAS (remote control services)	Right shoulder
Telephone antenna	Telephone	Roof-mounted antenna
Bluetooth antenna	Telephone	Wiring harness
Emergency call antenna	Telematics services	Left, rear inner wheel arch section

In vehicles with Radio Professional (standard equipment) or vehicles with Professional navigation system (option 609) a phase diversity is used.

The remote control service antenna is located on the right shoulder under the side window for the F31. The emergency call antenna is located on the left, rear inner wheel arch section.

The following graphic provides an overview of the other antenna system components.

F31 Complete Vehicle

10. Antenna Systems

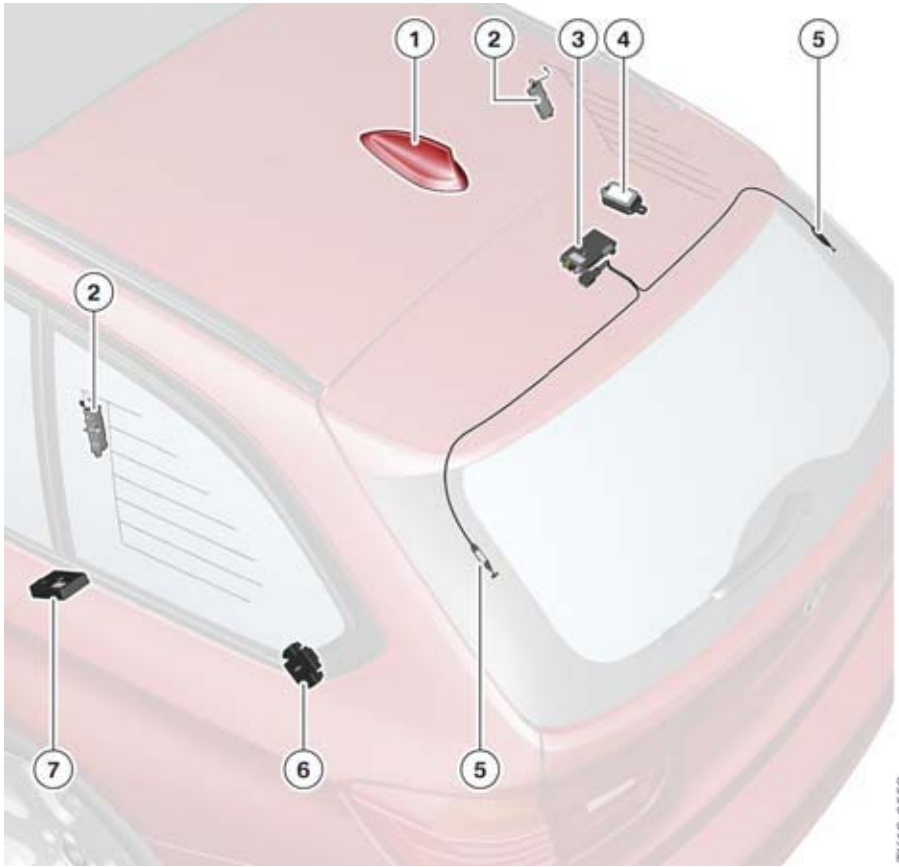

F31 antenna system

TK12-0558

Index	Explanation
1	Roof-mounted antenna
2	(not US)
3	Antenna diversity/Phase diversity
4	Remote control service antenna
5	Noise suppressor for heated rear window
6	Interference suppression filter for audio/additional brake light; wave trap, heated rear window
7	Emergency call antenna

You can see the layout of the antennas in the rear window on the following graphic.

F31 Complete Vehicle

10. Antenna Systems

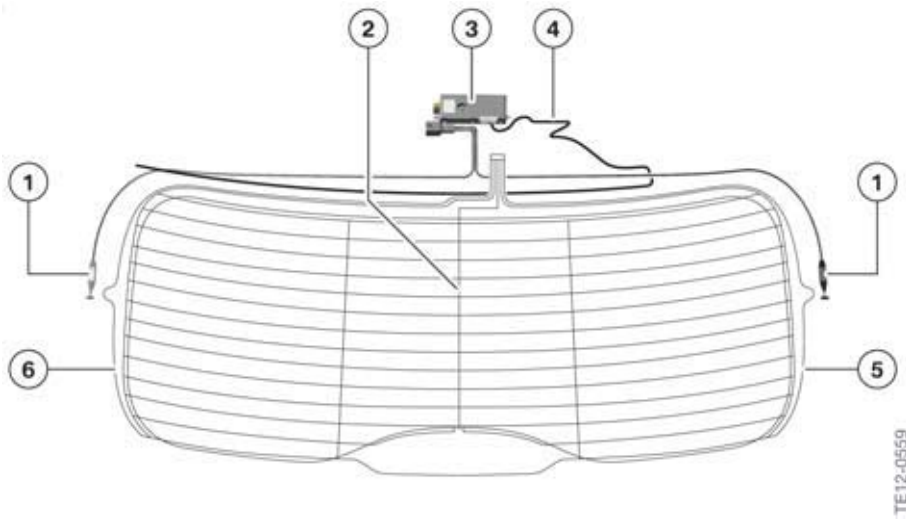

F31 antenna system, rear window

Index	Explanation
1	Noise suppressor for heated rear window
2	(not US)
3	Antenna diversity/Phase diversity
4	AM antenna
5	FM2 antenna
6	FM1 antenna

F31 Complete Vehicle

10. Antenna Systems

10.1. System wiring diagram

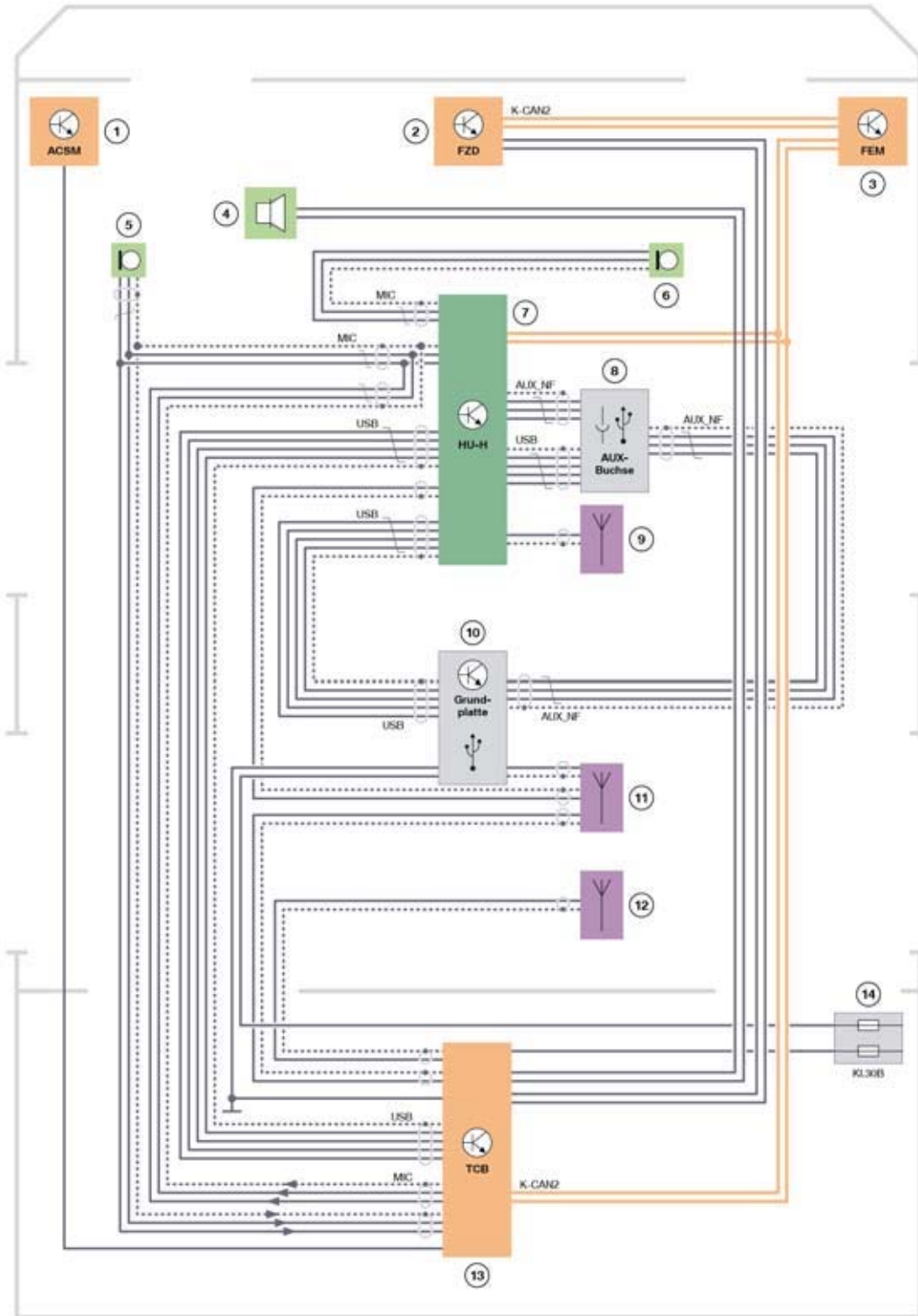

TE11-0297_2

F31 wiring diagram, antenna systems

F31 Complete Vehicle

10. Antenna Systems

Index	Explanation
1	Crash Safety Module (ACSM)
2	Roof function center (FZD)
3	Front Electronic Module (FEM)
4	Emergency loudspeaker
5	Microphone for the driver (MIC)
6	Microphone 2 for the front passenger (MIC2)
7	Headunit High
8	AUX-In connection with integrated USB audio interface
9	Bluetooth antenna
10	Video-compatible base plate for the snap-in adapter
11	Cell telephone antennas, GPS
12	Emergency GSM antenna
13	Telematic Communication Box (TCB)
14	Power distribution box, rear

F31 Complete Vehicle

11. BMW ConnectedDrive

11.1. BMW Apps

The optional equipment BMW Apps (option 6NR) was enhanced with the following two functions:

- ECO PRO analyzer
- Stitcher

The "Wiki Local" function was also enhanced.

So that the new functions are available, the corresponding version of the App must be installed on the iPhone®.

11.1.1. ECO PRO analyzer

The ECO PRO analyzer evaluates the driving style of the driver in the categories of acceleration, and route-ahead. The current evaluation of the driving style is shown on the CID. In the case of a consumption-optimized driving style stars are shown in the different categories and the unevenness in the road shown disappears.

The driver is also supported to adopt a driving style which optimizes consumption with the display of ECO PRO tips. The current journey can be compared to other journeys via a high score list. With the ECO PRO analyzer App on the iPhone® further details on the individual journeys can be called up. The ECO PRO analyzer function is available in the vehicle only when ECO PRO mode is activated and for vehicles with HU-H.



Sample displays, ECO PRO analyzer on the CID and on the iPhone®

Index	Explanation
A	Current evaluation of the driving style
B	High score list
C	App on the iPhone®

F31 Complete Vehicle

11. BMW ConnectedDrive

11.1.2. Stitcher

A new Internet radio service is available in conjunction with the optional equipment BMW Apps (option 6NR). The Stitcher App, developed by a third party and certified by BMW, allows the use of Internet radio services for news and information.

The user can compile personalized stations from a variety of programs. Via an evaluation system the user can assess the received contributions and receive program suggestions based on the evaluations of other users. The Stitcher App for the iPhone® can be downloaded free of charge from the iTunes® store.



Sample display, Stitcher on the CID

11.1.3. Wiki Local

The existing "Wiki Local" function was enhanced. The function can now also be used outside the vehicle on the iPhone®. The last search results and the saved favorites can be accessed.

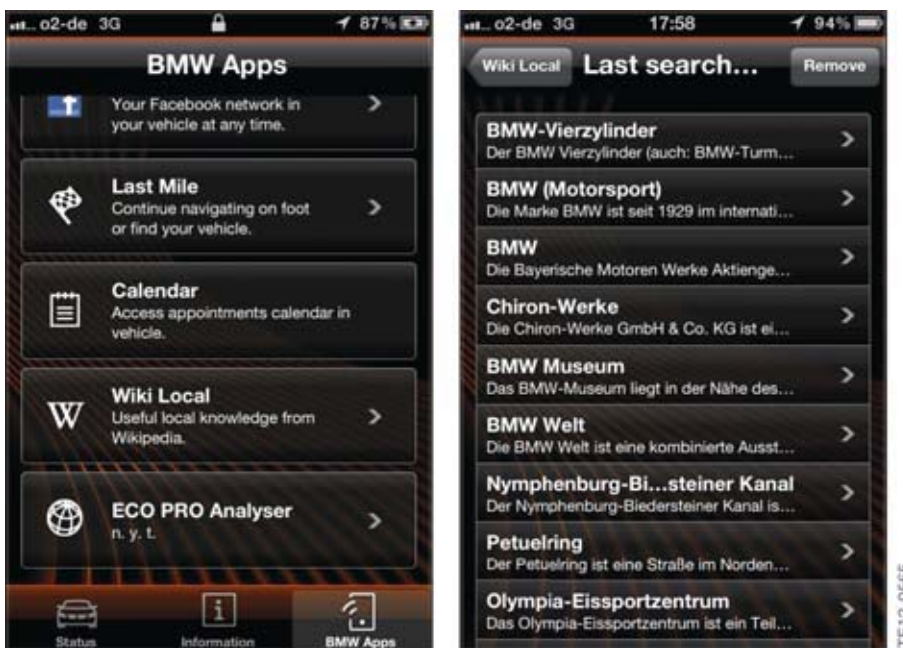

Sample display, Wiki Local on the iPhone®



Bayerische Motorenwerke Aktiengesellschaft
Qualifizierung und Training
Röntgenstraße 7
85716 Unterschleißheim, Germany