

Technical training.
Product information.

F48 Introduction



BMW Service

Edited for the U.S. market by:
BMW Group University
Technical Training

ST1508

9/1/2015

General information

Symbols used

The following symbol is used in this document to facilitate better comprehension or to draw attention to very important information:



Contains important safety information and information that needs to be observed strictly in order to guarantee the smooth operation of the system.

Information status and national-market versions

BMW Group vehicles meet the requirements of the highest safety and quality standards. Changes in requirements for environmental protection, customer benefits and design render necessary continuous development of systems and components. Consequently, there may be discrepancies between the contents of this document and the vehicles available in the training course.

This document basically relates to the European version of left-hand drive vehicles. Some operating elements or components are arranged differently in right-hand drive vehicles than shown in the graphics in this document. Further differences may arise as a result of the equipment specification in specific markets or countries.

Additional sources of information

Further information on the individual topics can be found in the following:

- Owner's Handbook
- Integrated Service Technical Application.

Contact: conceptinfo@bmw.de

©2015 BMW AG, Munich

Reprints of this publication or its parts require the written approval of BMW AG, Munich

The information contained in this document forms an integral part of the technical training of the BMW Group and is intended for the trainer and participants in the seminar. Refer to the latest relevant information systems of the BMW Group for any changes/additions to the technical data.

Information status: **June 2015**
BV-72/Technical Training

F48 Introduction

Contents

1.	Introduction	1
1.1.	Dimensions.....	2
1.2.	Weights and payload.....	2
1.3.	Silhouette comparison.....	3
2.	Bodyshell	4
2.1.	Material properties of bodyshell.....	4
3.	Emissions Reduction	5
4.	Doors, Lids and Hatches	6
4.1.	Doors.....	6
4.2.	Tailgate.....	8
4.2.1.	Automatic operation of tailgate.....	9
5.	Exterior Trim	10
5.1.	Panorama glass roof.....	10
6.	Interior Equipment	12
6.1.	Instrument panel.....	12
6.2.	Front door trim panel.....	13
6.3.	Front seats.....	14
6.4.	Rear seats.....	15
6.4.1.	Seat adjustment.....	17
6.4.2.	Backrest remote unlocking.....	18
7.	Luggage Compartment	22

F48 Introduction

1. Introduction

From October 2015 the new BMW F48 X1 will be available. Since the introduction of the E84 in August of 2012 , the F48 represents the second generation of the X1 Sports Activity Vehicle.

The F48 will currently be offered with xDrive only..
All engines in the F48 will be transversely mounted.

In the US the F48 comes standard with a xDrive system that works with a clutch instead of a transfer box for the longitudinal torque distribution.



TG15-06-49

BMW X1 – F48

In addition to the optional equipment, the F48 can also be individualized with the following equipment packages:

- Luxury package
- M sport package

F48 Introduction

1. Introduction

1.1. Dimensions

Below you see the outer dimensions of the F48 compared to the E84 using the example of the BMW X1 xDrive28i.

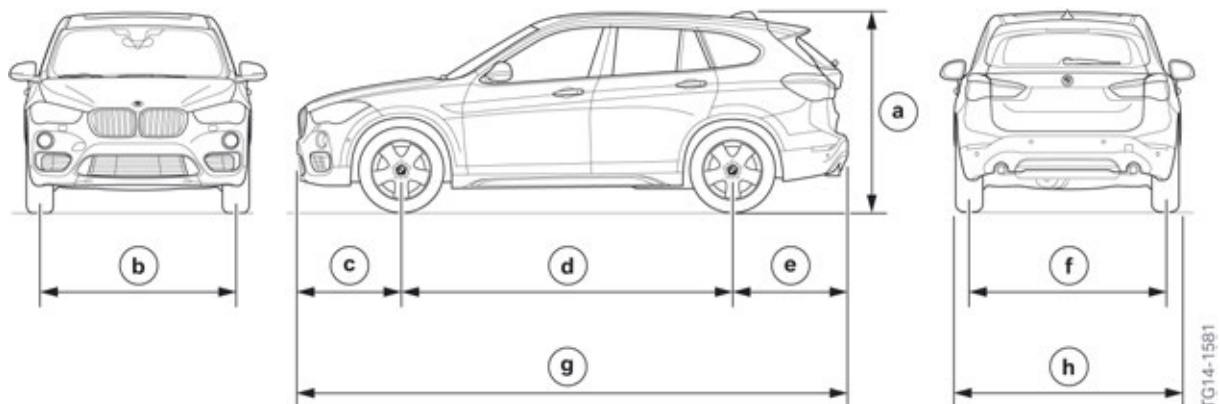

F48 Outer dimensions

Index	Explanation		F48	E84	Change
a	Vehicle height, empty	[mm]	1598	1545	+ 53
	ground clearance		183	161	+ 22
b	Front track width, basic wheels	[mm]	1561	1500	+ 61
c	Front overhang	[mm]	842	817	+ 25
d	Wheelbase	[mm]	2670	2760	- 90
e	Rear overhang	[mm]	927	907	+ 20
f	Rear track width, basic wheels	[mm]	1562	1529	+ 33
g	Vehicle length	[mm]	4439	4484	- 45
h	Width excluding exterior mirrors (vehicle width including exterior mirrors)		1821	1798	+ 23
			(2060)	(2058)	(+ 2)

1.2. Weights and payload

Vehicle curb weights and payloads of the F48 are set out in the following table:

		F48	E84
Vehicle curb weight (DIN)	[kg] lbs	1660 / 3660	1600 / 3527
Permissible total weight	[kg] lbs	2140 / 4720	2040 / 4497
Payload	[kg] lbs	408 / 900	550 / 1212
Roof load	[kg] lbs	75 / 165	75 / 165

F48 Introduction

1. Introduction

1.3. Silhouette comparison

F48
E84

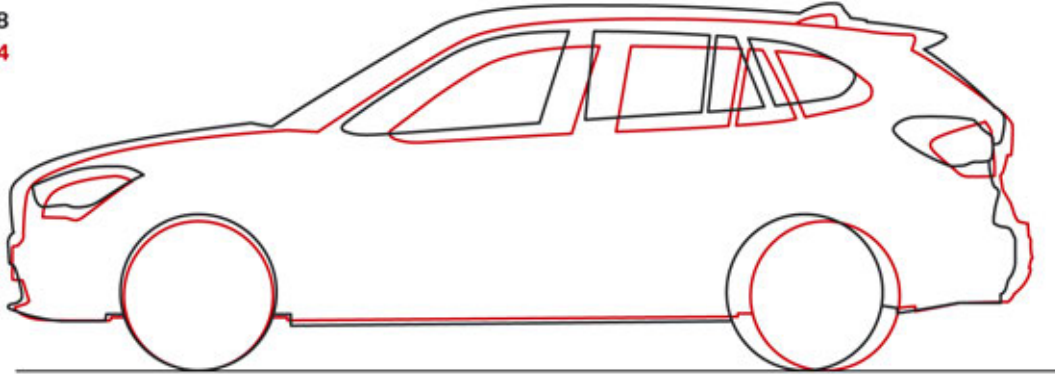

F48 silhouette comparison with BMW X1 E84

TG14-1582

F48
F25
F15

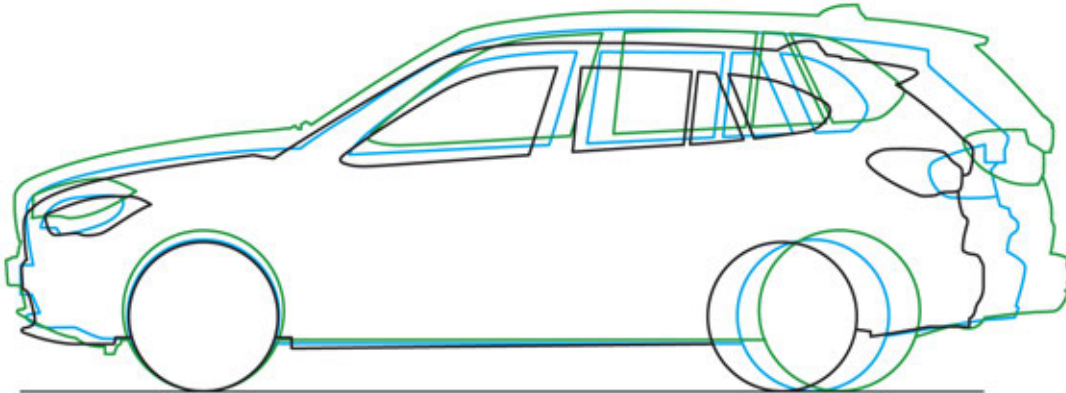

F48 silhouette comparison with BMW X3 F25 and BMW X5 F15

TG14-1583

F48 Introduction

2. Bodyshell

2.1. Material properties of bodyshell

The use of state-of-the-art steels, as well as the intelligent material mix, has a positive effect on the vehicle weight. The distinctive body rigidity ensures the driving dynamics typical of BMW.

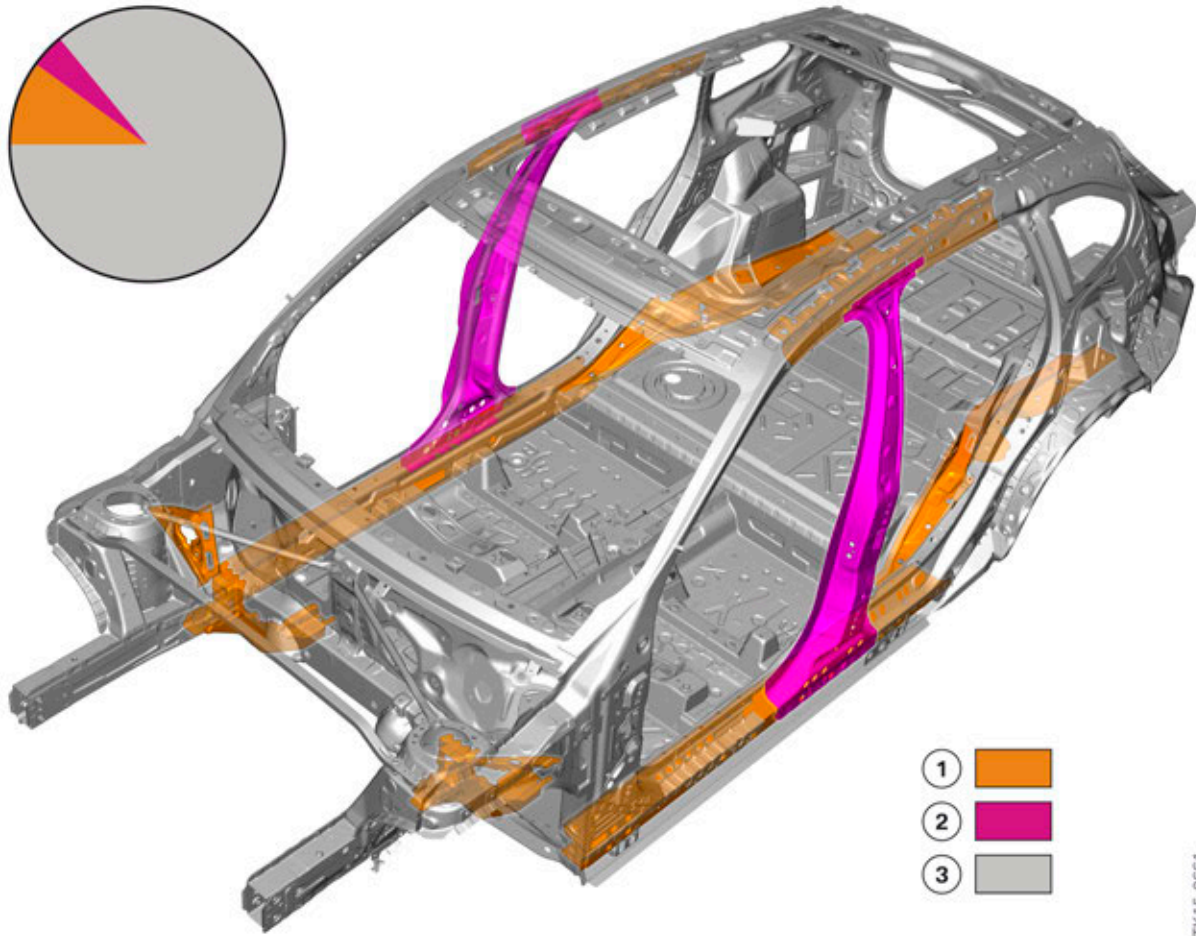

F48 Material properties of bodyshell

Index	Explanation
1	Multi-phase steels (> 300 MPa), 9 % of the body weight
2	Hot-formed steels (> 900 MPa), 4 % of the body weight
3	Other steels (< 300 MPa), 87 % of the body weight

Multi-phase steels are steels where the structure consists of a number of phases. Higher-strength multi-phase steels with a yield strength $R_{p0.2}$ of 300 to 600 MPa are, for example, dual-phase steels or TRIP steels. Super-strength multi-phase steels with a yield strength $R_{p0.2}$ in excess of 600 MPa are, for example, complex-phase steels or martensitic-phase steels.

Hot-formed manganese-boron steels are super-strength steels with a yield strength $R_{p0.2}$ in excess of 900 MPa.

F48 Introduction

3. Emissions Reduction

In addition to the measures in the drive and chassis and suspension area, the weight reduction of the body, as well as the aerodynamics measures, help reduce the CO₂ emissions of the F48.

A low body weight was also able to be achieved with the following measures:

- Bulkhead, carrier support and B-pillar made from Taylor Rolled blanks (optimized material thickness).
- Bumper support, front and rear, made from aluminium.
- Engine compartment lid made from aluminium
- High use of high-strength and super-strength multiphase steels and super-strength, hot-formed steels

The following measures ensure a low drag:

- Air ducts in front of the front wheel arches ("Air Curtain").
- Aeroblades and air guides in front of the front wheels ("Displacer").
- Rear spoiler and aeroblades at the side at the tailgate

F48 Introduction

4. Doors, Lids and Hatches

4.1. Doors

The F48 outer door skin is welded to the inner door panel, in order to increase the rigidity of the doors.

A further increase of the rigidity is achieved by additional laser welded seams between the inner door panels and the end plates:

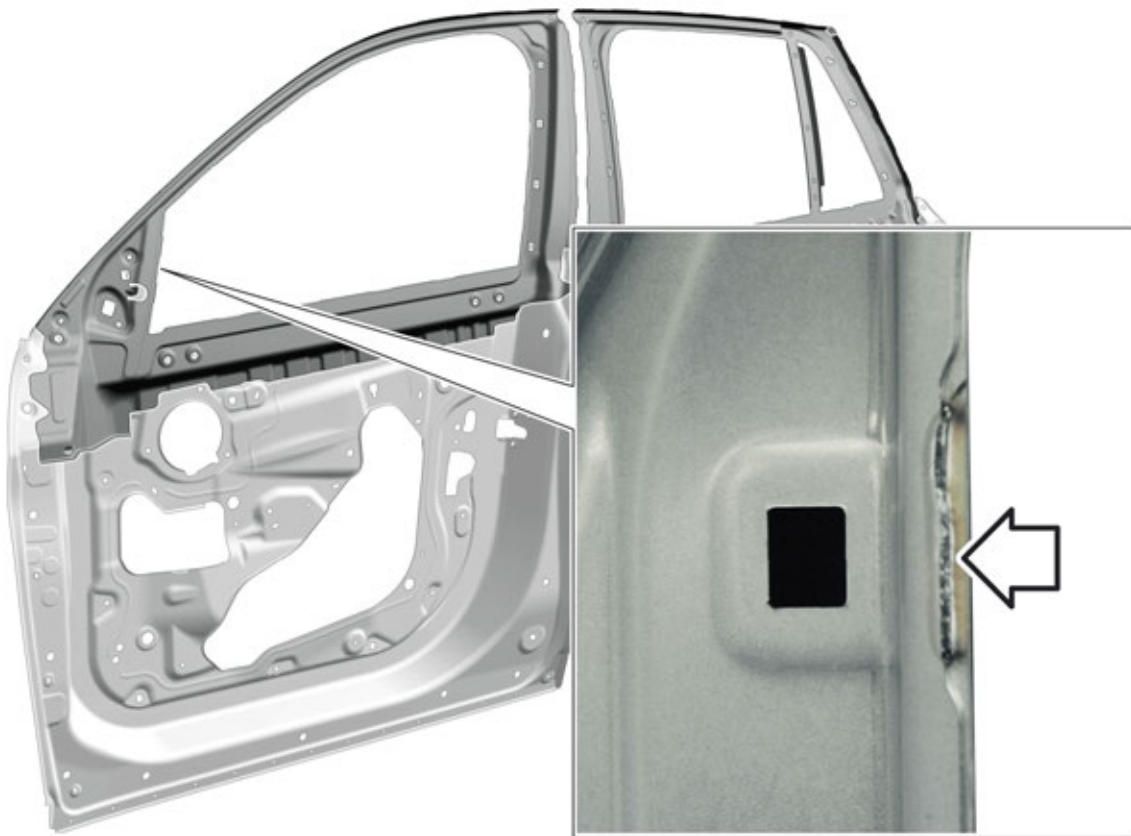

TK15-0662

F48 laser weld seams, doors

F48 Introduction

4. Doors, Lids and Hatches



F48 sealing tape, doors

In order to reduce the noise level in the passenger compartment, additional sealing tape is clipped on to the inner door panels. The tape also helps reduce contamination in the sill areas.

F48 Introduction

4. Doors, Lids and Hatches

4.2. Tailgate



F48 aeroblades, tailgate

Index	Explanation
1	Rear spoiler
2	Aeroblades

Like in the F15, aeroblades are also attached at the side of the tailgate in the F48. Tear-off edges occur as a result of the side aeroblades and the rear spoiler, which cause the specific stall at the D-pillar. This lowers the total drag of the vehicle.

F48 Introduction

4. Doors, Lids and Hatches

4.2.1. Automatic operation of tailgate



F48 Automatic operation of tailgate

An automatic operation of tailgate (SA 316) is standard for the F48. As is known from current BMW models, the tailgate is opened or closed by an electric spindle on the drivers side.

Two hall effect sensors are installed in the spindle drive to detect the position of the tailgate. These are read out from the control unit for the automatic operation of the tailgate.

The tailgate opens or closes automatically when it is actuated by one of the following buttons:

- Button for the remote control or ID transmitter
- Button on the tailgate, outer or inner
- Button on the driver's door

In conjunction with the optional equipment Comfort Access (SA 322), the tailgate can also be opened hands free by means of targeted foot movement. Two sensors detect the movement contactlessly via capacitive measurement.

F48 Introduction

5. Exterior Trim

5.1. Panorama glass roof

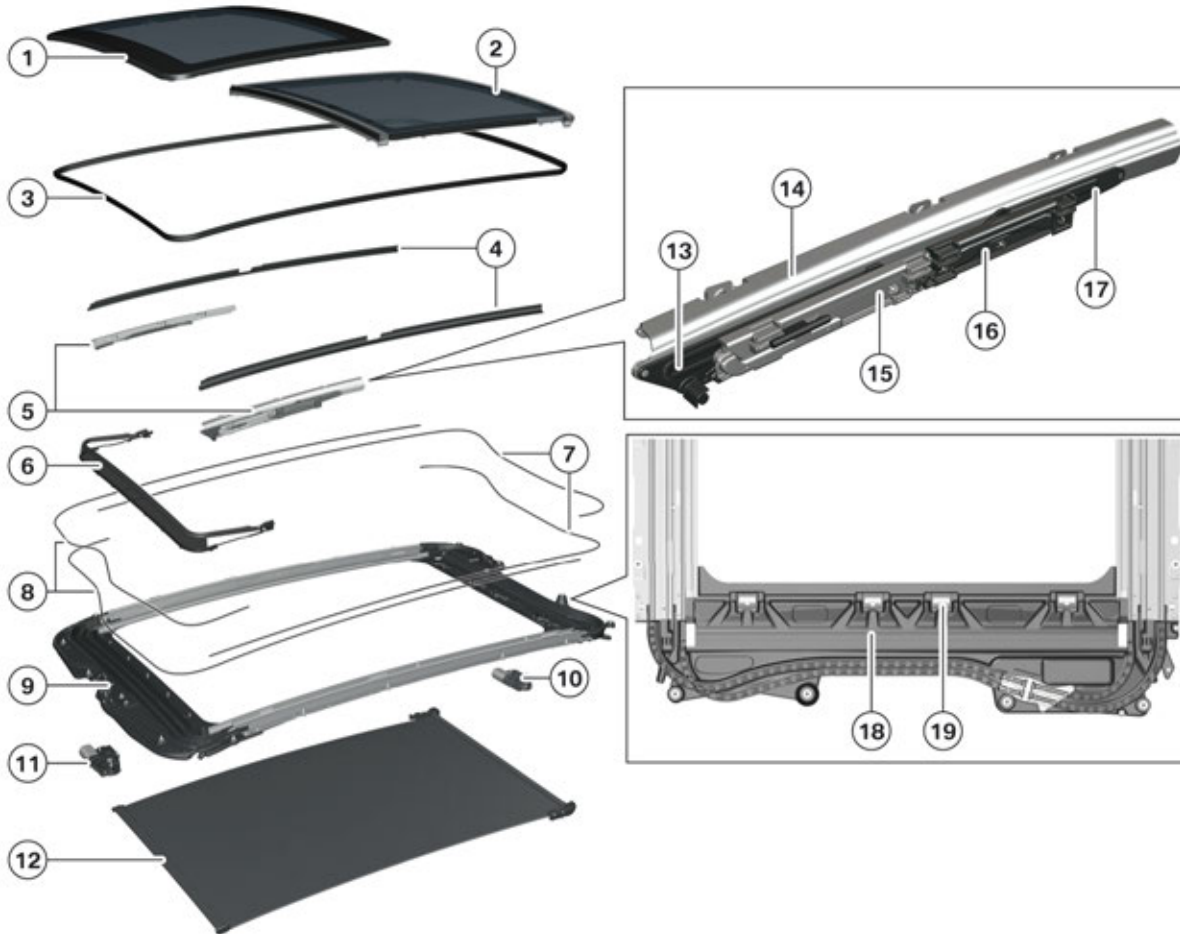

TK13-2703

F48 panorama glass roof

Index	Explanation
1	Glass slide/tilt sunroof panel (moveable)
2	Glass slide/tilt sunroof panel (tightly screwed)
3	Gasket
4	Side panel
5	Kinematics
6	Wind deflector
7	Bowden cable (roller sunblind)
8	Bowden cable (glass slide/tilt sunroof panel)
9	Frame
10	Electric motor (roller sunblind)
11	Electric motor (glass slide/tilt sunroof panel)

F48 Introduction

5. Exterior Trim

Index	Explanation
12	Roller sunblind
13	Positioning lever, front
14	Sliding carriage
15	Gate, front
16	Gate, rear
17	Positioning lever, rear
18	Rear part of frame
19	Steel inlay

The optional panorama glass roof (SA 402) allows greater outside light in the vehicle when the roller sunblind is open. For the first time at BMW, when fully opening the panorama glass roof, the front glass slide/tilt sunroof panel is pushed outwards across the rear glass slide/tilt sunroof panel.

The roller sunblind is electrically adjustable. If the glass slide/tilt sunroof panel is put into a vent position, the roller sunblind moves back for the necessary air circulation. Side panels cover the area between the frame and the glass slide/tilt sunroof panel.

The rear and front parts of the frame are made from plastic with steel inlays in order to reduce the weight and lower the vehicle's center of gravity.

The following components of the panorama glass roof can be replaced without removing the roof liner:

- Side panel, left
- Side panel, right
- Wind deflector
- Glass slide/tilt sunroof panel, front
- Glass slide/tilt sunroof panel, rear

An emergency operation of the glass slide/tilt sunroof panel is possible using a hexagon socket wrench at the front drive.

F48 Introduction

6. Interior Equipment

6.1. Instrument panel



F48 instrument panel, center console

All F48 vehicles come standard with automatic air conditioning (SA 534), the glove box is also equipped with additional ventilation.

A fold-down compartment on the driver's side dashboard below the headlight switch adds additional storage.

F48 Introduction

6. Interior Equipment

6.2. Front door trim panel



F48 front door trim panel

Index	Explanation
1	Fiber-optic conductor
2	Button, tailgate activation

The door trim panel on the drivers side also incorporates the button for the tailgate activation.

Depending on the vehicle equipment, the door trim panels are also equipped with fibre-optic conductors over the decorative strips.

F48 Introduction

6. Interior Equipment

6.3. Front seats

Power front seats with drivers side memory is standard. Along with ISOFIX child seat mountings.

An integrated side airbag, as well as a seat belt system with belt tensioner, are used for all front seat versions of the F48. The following equipment can be ordered:

- Sport seats for driver and front passenger (SA 481)
- Lumbar support for driver and front passenger (SA 488)
- Seat heating for driver and front passenger (SA 494)
- Heated front seats (SA 494)

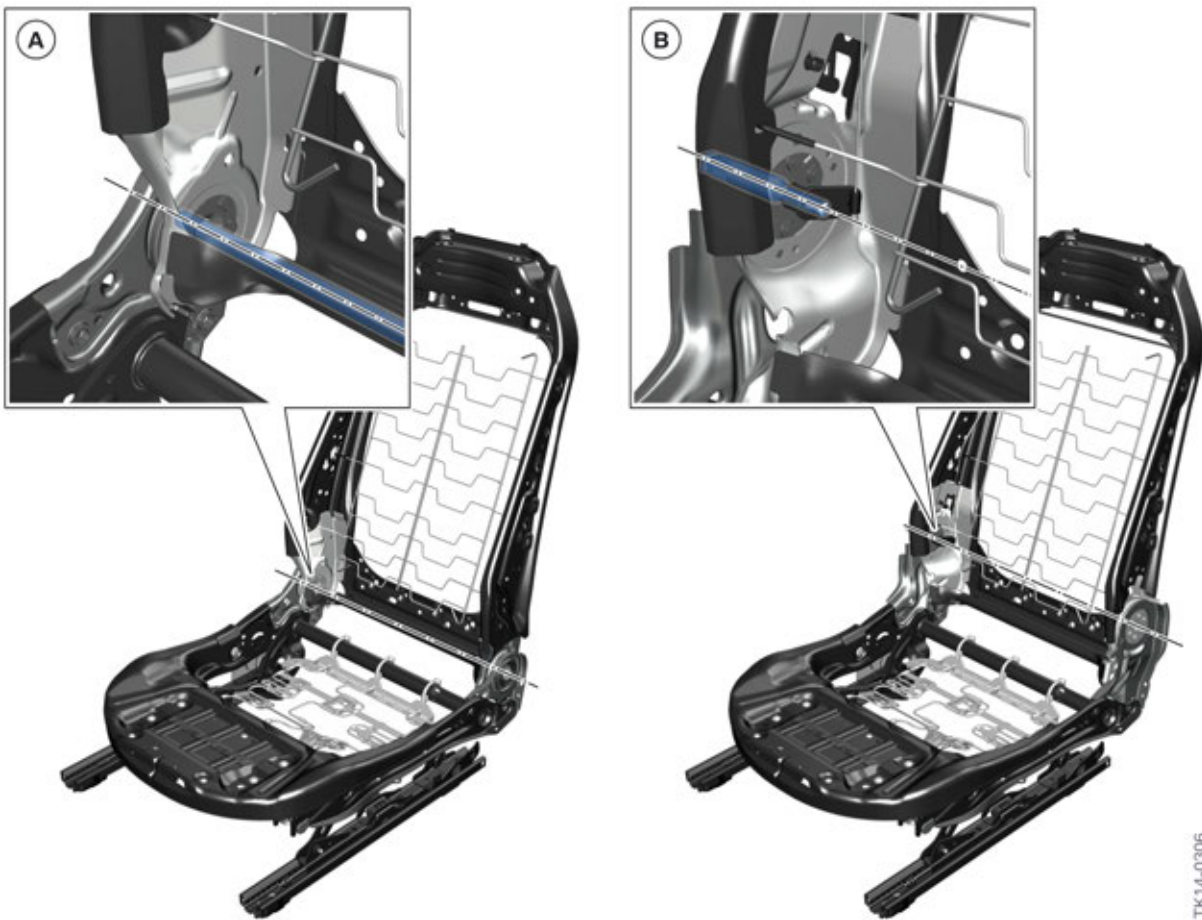

TK14-0306

F48 backrest at front passenger seat

Index	Explanation
A	Basic seat
B	Folding-down front passenger backrest (Not For US)

F48 Introduction

6. Interior Equipment

6.4. Rear seats



F48 rear seats

The rear seat backrest is divided as standard into three sections in the ratio 40:20:40. Each individual section can be folded forwards separately via a loop at the rear seat backrest lower section. In the F48 the rear seat backrests are no longer secured to the body using a connection, but are only secured at the pivot points via the latch mechanism.

The rear head restraints can be adjusted very far downwards thanks to their L-shape, thus offering an optimal view of the rear.

F48 Introduction

6. Interior Equipment

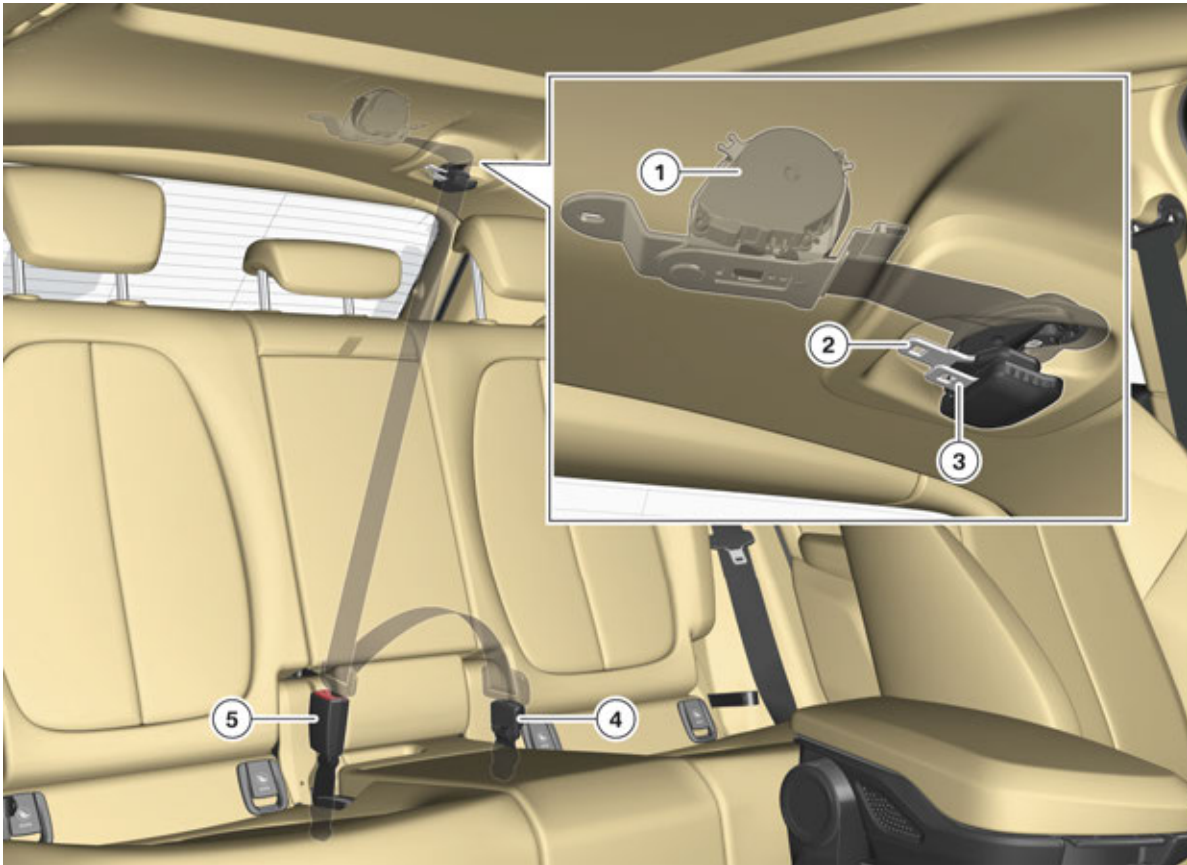

F48 middle seat belt in the rear passenger compartment

Index	Explanation
1	Inertia reel
2	Top buckle
3	Bottom buckle
4	Seat belt buckle (for bottom buckle)
5	Seat belt buckle (for top buckle)

Another new feature at BMW concerns the middle seat belt in the rear passenger compartment, whose inertia reel is housed between the roof and roof-liner. There are two buckles at the end of the seat belt, which are retained magnetically at the belt holder. To close the middle seat belt, the bottom buckle (3) must be inserted in the left seat belt buckle (4) and the top buckle (2) in the right seat belt buckle (5).

The right seat belt buckle (5) is released using the red button in the buckle. The left seat belt buckle (4) is released using the belt end.

F48 Introduction

6. Interior Equipment

6.4.1. Seat adjustment



F48 examples of seat adjustment for rear seat

With the optional equipment "Sliding and Reclining rear seat adjustment" (SA 4FD), the seat bench is divided in the ratio 60:40. Both sides can be adjusted 130 mm in a longitudinal direction, independent of each other.

In addition, the inclination of the rear seat backrests can be adjusted in 2° steps. For instance, the seating comfort in the rear passenger compartment or the size of the luggage compartment can be optimized, depending on requirements.

TK15-1106

F48 Introduction

6. Interior Equipment

6.4.2. Backrest remote unlocking

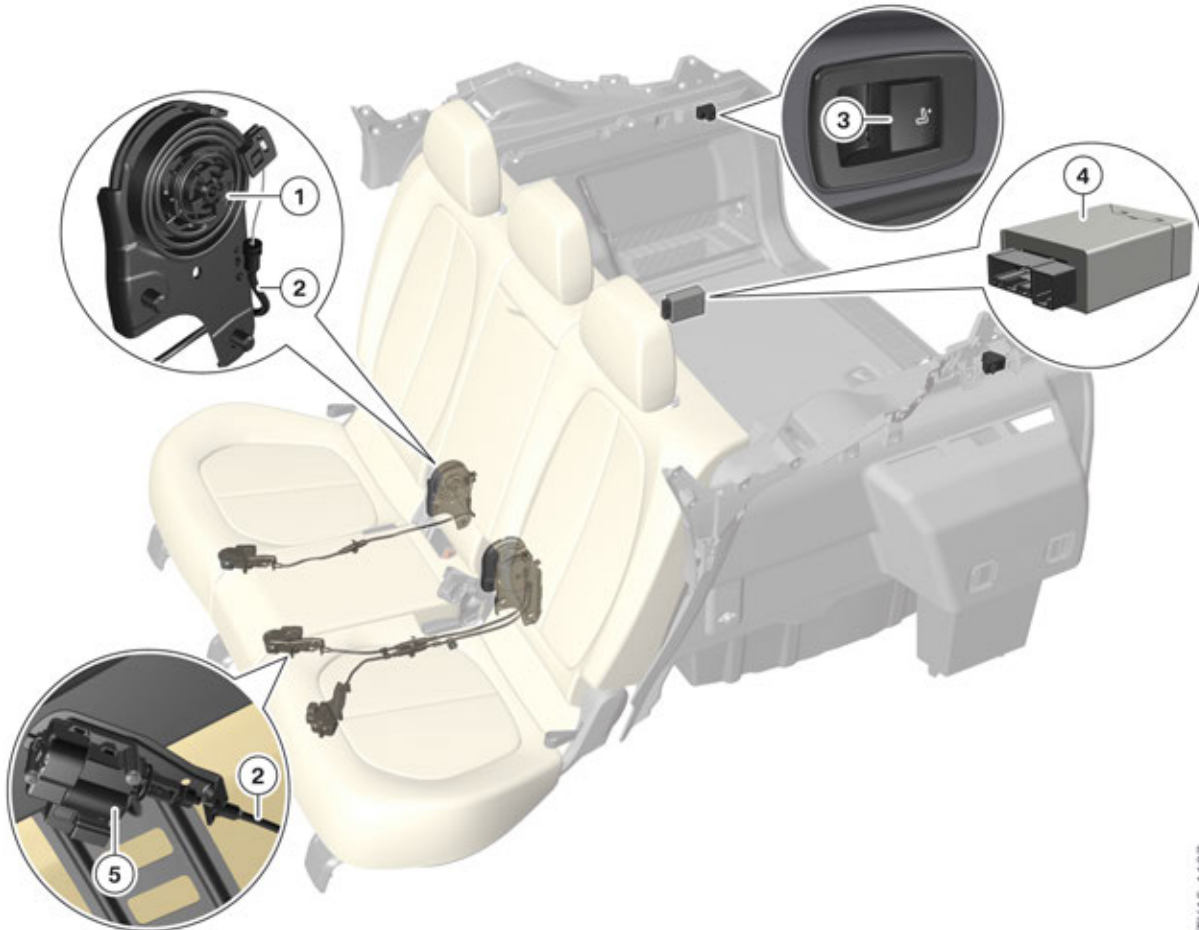

TK15-1107

F48 Backrest remote unlocking

Index	Explanation
1	Latch mechanism (at the pivot points)
2	Bowden cable
3	Button, backrest remote unlocking
4	Control unit, backrest remote unlocking
5	Motor, backrest remote unlocking

In conjunction with the optional equipment "Sliding and Reclining rear seat adjustment" (SA 4FD), an electric remote unlocking of the rear seat backrests is also used. The corresponding rear seat backrests are unlocked electrically and then fold forwards by spring tension.

The two buttons of the backrest remote unlocking are located in the luggage compartment on the left and right. By pressing the left button, the left and middle section of the rear seat backrest folds forward. By pressing the right button, the right section of the rear seat backrest folds forwards.

F48 Introduction

6. Interior Equipment

The control unit for the backrest remote unlocking reads the two buttons and activates the three motors of the backrest remote unlocking with a time delay. The control unit is located under the right storage compartment in the luggage compartment and does not have diagnostic capability.

F48 Introduction

6. Interior Equipment

System wiring diagram

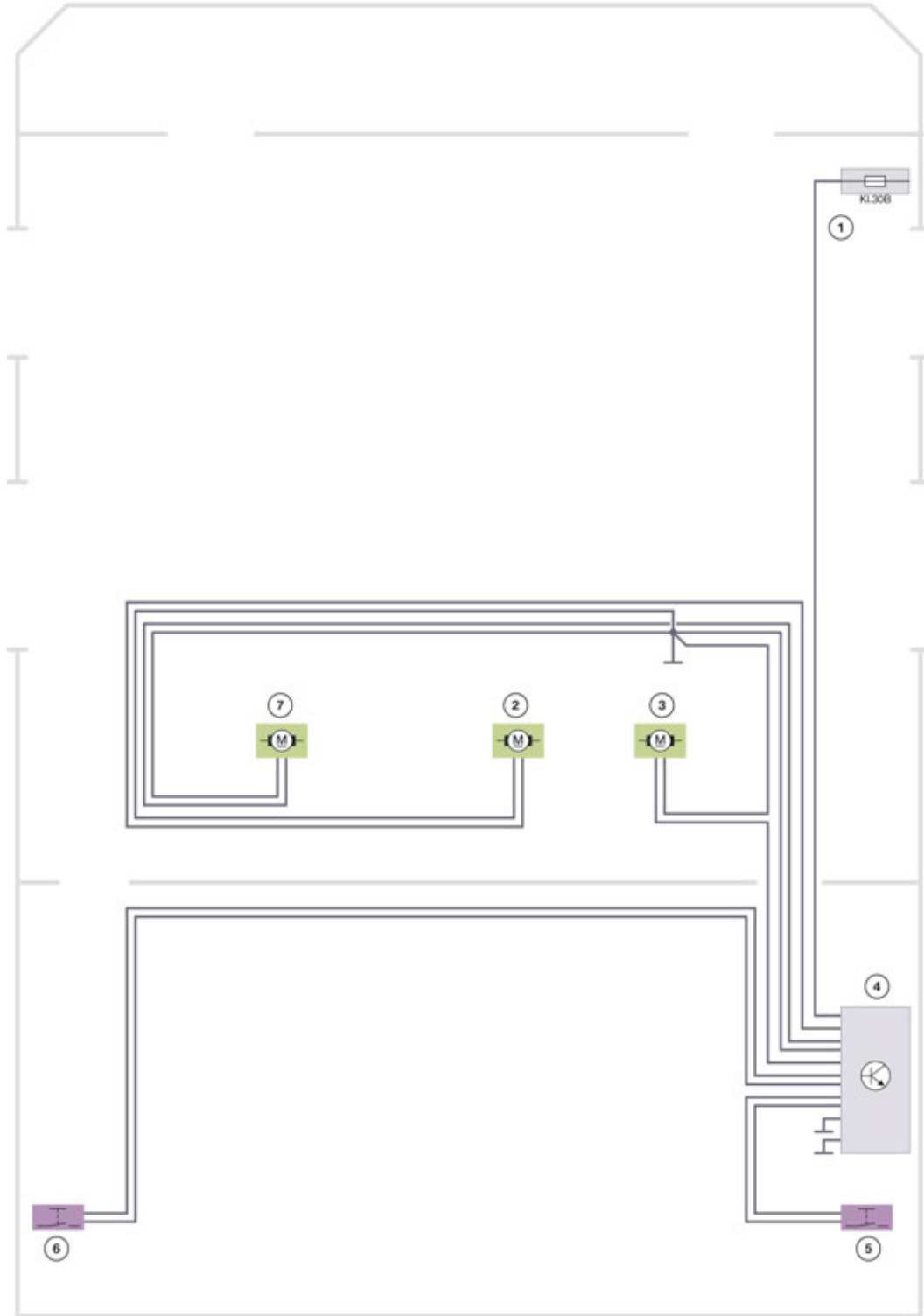

TE13-2697

F48 system wiring diagram for backrest remote unlocking

F48 Introduction

6. Interior Equipment

Index	Explanation
1	Power distribution box, passenger compartment
2	Motor, backrest remote unlocking, middle
3	Motor, backrest remote unlocking, right
4	Control unit, backrest remote unlocking
5	Button, backrest remote unlocking, right
6	Button, backrest remote unlocking, left
7	Motor, backrest remote unlocking, left

F48 Introduction

7. Luggage Compartment



TK15-1108

F48 examples of functional spatial concept

The luggage compartment capacity of the F48 is 505 liters and can be extended up to 1550 liters.

The spatial offering can be used variably thanks to the functional spatial concept. Depending on the vehicle equipment, the following options are offered to change the luggage compartment capacity:

- Folding down the rear seat backrest (separated in the ratio 40:20:40)
- Tilt adjustment of the rear seat backrests (separated in the ratio 40:20:40)
(Sliding and Reclining rear seat adjustment (SA 4FD))
- Forward/back adjustment of the seat bench (separated in the ratio 60:40)
(Sliding and Reclining rear seat adjustment (SA 4FD))

A foldable luggage compartment floor enables easy access to the storage room underneath.



Bayerische Motorenwerke Aktiengesellschaft
Qualifizierung und Training
Röntgenstraße 7
85716 Unterschleißheim, Germany