

Technical training.
Product information.

F48 General Vehicle Electronics



BMW Service

Edited for the U.S. market by:
BMW Group University
Technical Training

ST1508

9/1/2015

General information

Symbols used

The following symbol is used in this document to facilitate better comprehension or to draw attention to very important information:



Contains important safety information and information that needs to be observed strictly in order to guarantee the smooth operation of the system.

Information status and national-market versions

BMW Group vehicles meet the requirements of the highest safety and quality standards. Changes in requirements for environmental protection, customer benefits and design render necessary continuous development of systems and components. Consequently, there may be discrepancies between the contents of this document and the vehicles available in the training course.

This document basically relates to the European version of left-hand drive vehicles. Some operating elements or components are arranged differently in right-hand drive vehicles than shown in the graphics in this document. Further differences may arise as a result of the equipment specification in specific markets or countries.

Additional sources of information

Further information on the individual topics can be found in the following:

- Owner's Handbook
- Integrated Service Technical Application.

Contact: conceptinfo@bmw.de

©2015 BMW AG, Munich

Reprints of this publication or its parts require the written approval of BMW AG, Munich

The information contained in this document forms an integral part of the technical training of the BMW Group and is intended for the trainer and participants in the seminar. Refer to the latest relevant information systems of the BMW Group for any changes/additions to the technical data.

Information status: **June 2015**
BV-72/Technical Training

F48 General Vehicle Electronics

Contents

1. Vehicle Electrical System	1
1.1. Data bus overview	1
1.2. Main bus systems	3
1.2.1. K-CAN	3
1.2.2. PT-CAN	8
1.2.3. FlexRay	9
1.2.4. D-CAN	13
1.2.5. Ethernet	13
1.2.6. MOST	13
1.3. Sub-bus systems	13
1.3.1. Local interconnect network bus	13
1.3.2. Local-CAN	14
1.3.3. USB	14
1.3.4. APIX	14
1.4. Control units	15
1.4.1. Complete overview	15
1.4.2. Body Domain Controller	17
1.4.3. Frontal Light Electronics	17
1.4.4. TRSVC control unit	18
1.4.5. Park Distance Control/Parking Maneuver Assistant	19
1.4.6. Crash Safety Module	20
1.4.7. Dynamic Stability Control	20
1.4.8. Optional equipment system	21
1.4.9. Camera-based driver support systems	22
1.4.10. Automatic operation of tailgate	23
1.4.11. Longitudinal torque distribution	23
2. Voltage Supply	24
2.1. Overview	24
2.2. Components	26
2.2.1. Battery	27
2.2.2. Intelligent battery sensor	27
2.2.3. Power distribution boxes	28
3. Exterior Lights	30
3.1. Headlights	30
3.1.1. Halogen headlight	30
3.1.2. LED headlight with extended scope	31
3.1.3. fog lights	34
3.2. Rear lights	35
3.2.1. In vehicles with halogen headlights	35

F48 General Vehicle Electronics

Contents

3.2.2.	Vehicles with LED headlights.....	36
4.	Interior Lighting.....	37
4.1.	System wiring diagram.....	38
5.	Heating/Air Conditioning Systems.....	41
5.1.	Components and systems.....	41
5.1.1.	Integrated automatic heating and air conditioning.....	41
5.1.2.	Heating and air-conditioning unit.....	46
5.1.3.	Microfilter.....	48
5.1.4.	Air/Water separation (Venturi adapter).....	49
5.1.5.	ECO PRO mode of heating and air conditioning program.....	51
6.	Locking and Security Functions.....	52
6.1.	Overview of functions.....	54
6.1.1.	Remote control receiver.....	55
6.2.	Central locking system.....	55
6.2.1.	Special functions.....	56
6.2.2.	System wiring diagram.....	57
6.3.	Comfort Access.....	59
6.3.1.	System wiring diagram.....	60
6.3.2.	System components.....	62
6.4.	Hands free tailgate opening.....	63
6.4.1.	System wiring diagram.....	64
6.4.2.	Functional description of tailgate opening.....	65
7.	Alarm System.....	69
7.1.	System wiring diagram.....	69
8.	Wash/Wipe System.....	71
8.1.	Introduction.....	71
8.2.	Operation.....	71
8.3.	System wiring diagram.....	72
9.	Steering Wheel Heating.....	74
9.1.	System wiring diagram.....	74

F48 General Vehicle Electronics

1. Vehicle Electrical System

1.1. Data bus overview

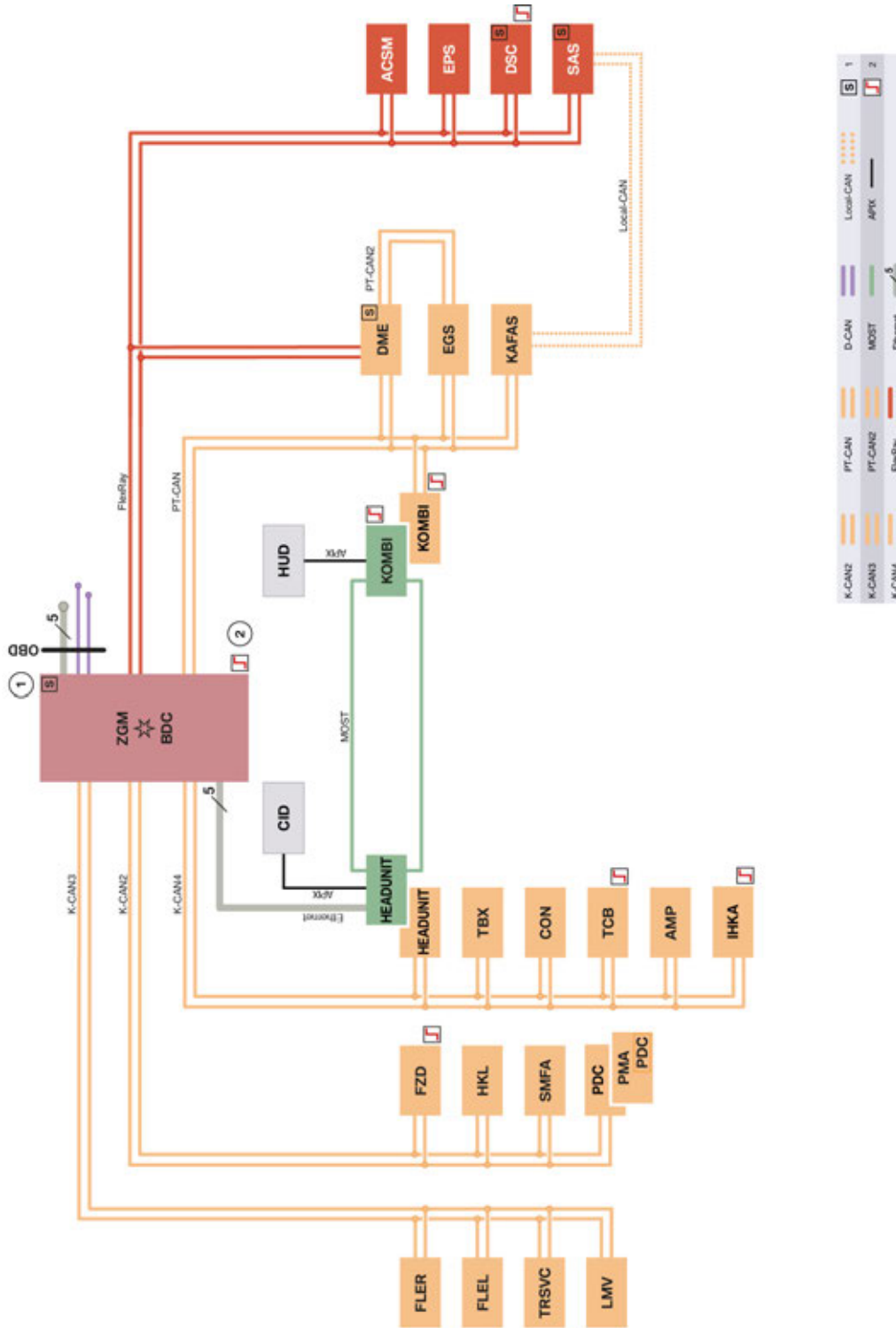

F48 data bus overview

F48 General Vehicle Electronics

1. Vehicle Electrical System

Index	Explanation
1	Start-up node control units for starting and synchronizing the FlexRay bus system
2	Control units with wake-up authorisation
ACSM	Advanced Crash Safety Module
AMP	Audio amplifier
BDC	Body Domain Controller
CID	Central information display
CON	Controller
DME	Digital Motor Electronics
DSC	Dynamic Stability Control
EGS	Electronic transmission control
EPS	Electronic Power Steering
FLEL	Frontal Light Electronics Left
FLER	Frontal Light Electronics Right
FZD	Roof function center
HEADUNIT	Headunit
HKL	Automatic operation of tailgate
HUD	Head-Up Display
IHKA	Integrated heating and air conditioning
KAFAS	Camera-based driver support systems
KOMBI	Instrument cluster
LMV	Longitudinal torque distribution
PDC	Park Distance Control
PMA	Parking Manoeuvring Assistant
SAS	Optional equipment system
SMFA	Driver's seat module
TBX	Touchbox
TCB	Telematic Communication Box
TR SVC	Control unit for rear view camera and Side View
ZGM	Central gateway module

F48 General Vehicle Electronics

1. Vehicle Electrical System

1.2. Main bus systems

1.2.1. K-CAN

In the F48 the following K-CANs are used:

- K-CAN2
- K-CAN3
- K-CAN4

All K-CAN data buses have a data transfer rate of 500 kBit/s.

The K-CAN with 100 kBit/s is no longer used in the F48.

F48 General Vehicle Electronics

1. Vehicle Electrical System

K-Can termination

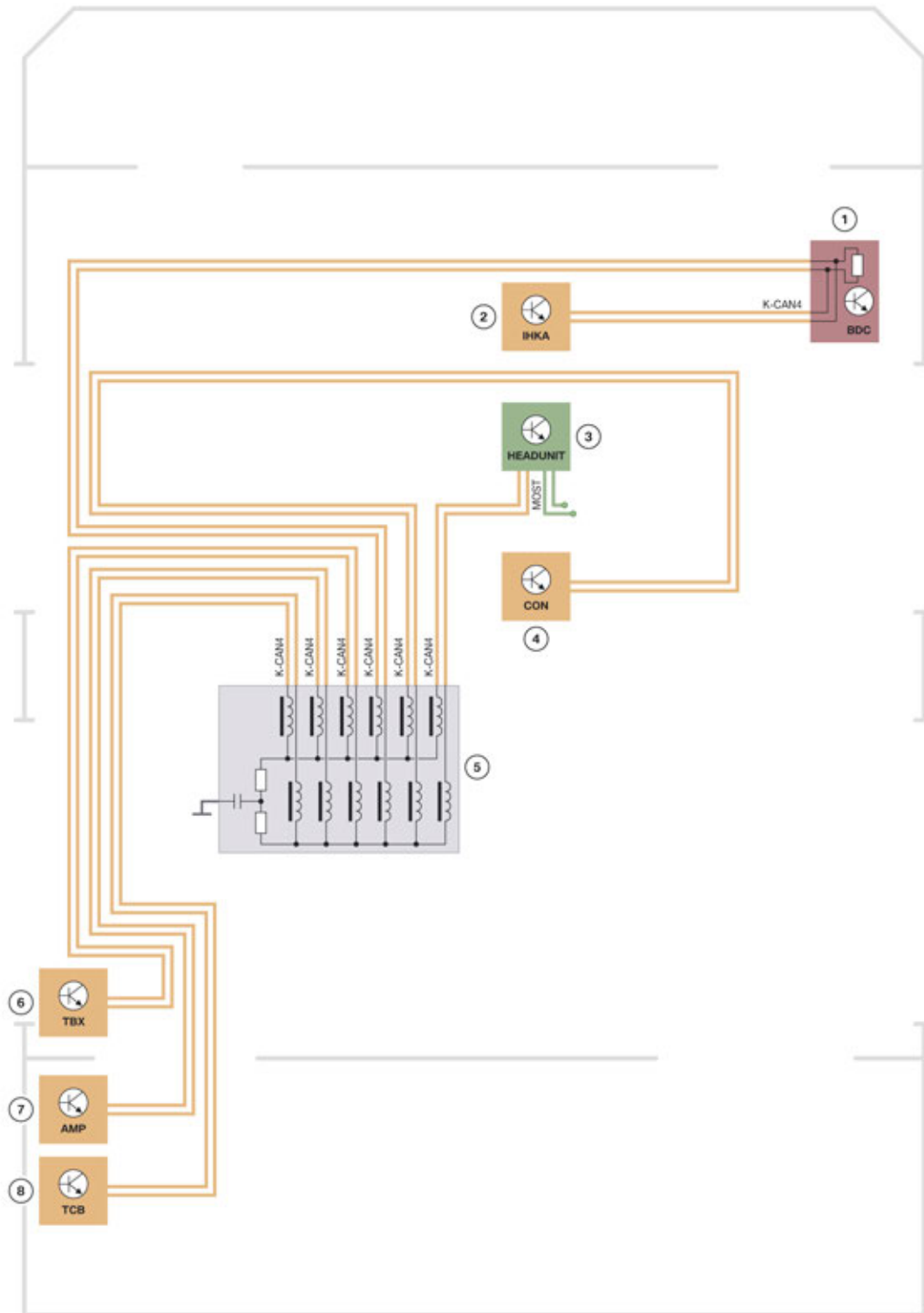

TE13-2568

F48 K-Can termination

F48 General Vehicle Electronics

1. Vehicle Electrical System

Index	Explanation
1	Body Domain Controller (BDC)
2	Integrated heating and air conditioning
3	Headunit
4	Controller (CON)
5	K-CAN terminator
6	Touchbox (TBX)
7	Audio amplifier (AMP)
8	Telematic Communication Box (TCB)

The CAN buses are shown in the overview of the bus systems. The actual physical layout (topology) is shown using the example of the K-CAN2.

As with most bus systems, terminating resistors are also used for protection of the K-CAN to avoid residual voltages on the data lines.

The terminating resistors for the termination are located in the:

- Body Domain Controller and
- K-CAN terminators.

All other control units are connected at the K-CAN terminator without a terminating resistor.

F48 General Vehicle Electronics

1. Vehicle Electrical System

CAN terminator

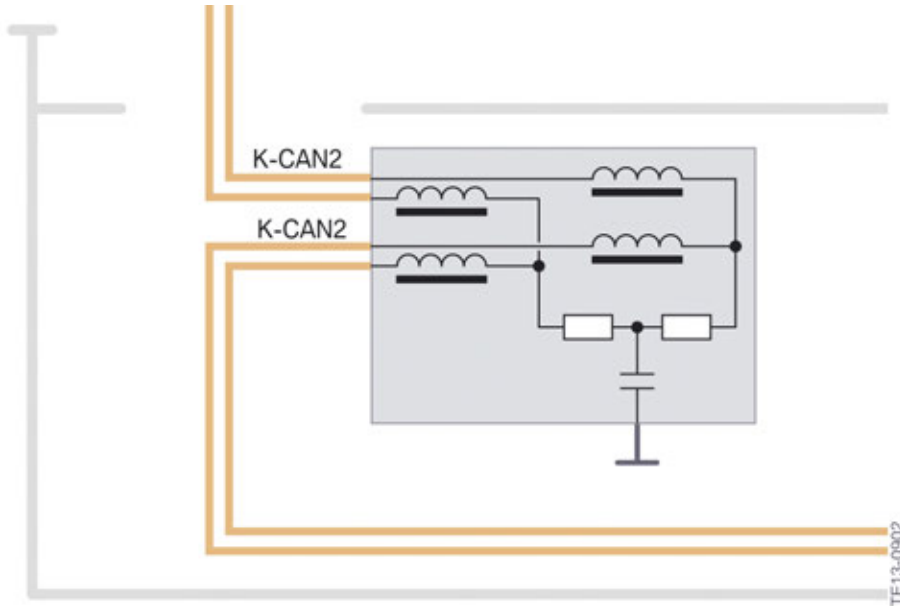

CAN terminator

Depending on the equipment package, in the CAN terminator the terminating resistor for the corresponding CAN bus is installed. The terminating resistor comprises two resistances connected in series, each 60 Ohm. A measuring tap against ground with a capacitor for the reduction of high-frequency faults is also installed. Ferrite beads are installed for all bus lines in the CAN terminator. Ferrite beads suppress high-frequency faults on the CAN data lines, thus making possible line lengths of up to 5 m in the wiring harness.

Ferrite core

A ferrite core is a component made from the ferromagnetic material iron oxide hematite (Fe_2O_3). It is characterized by low or no conductivity. The inductance or the magnetic field is increased as part of a coil (throttle or transformer). If a ferrite core is secured around a conductor, which routes signals at low frequency or direct current voltage, high-frequency faults are attenuated with its help.



Ferrite core

Index	Explanation
1	Ferrite core using the example of a USB line

F48 General Vehicle Electronics

1. Vehicle Electrical System

Oscilloscope

If there are no terminating resistors in a CAN bus or they are faulty, this may lead to reflections or faults. These reflections or faults are shown in the following graphic:

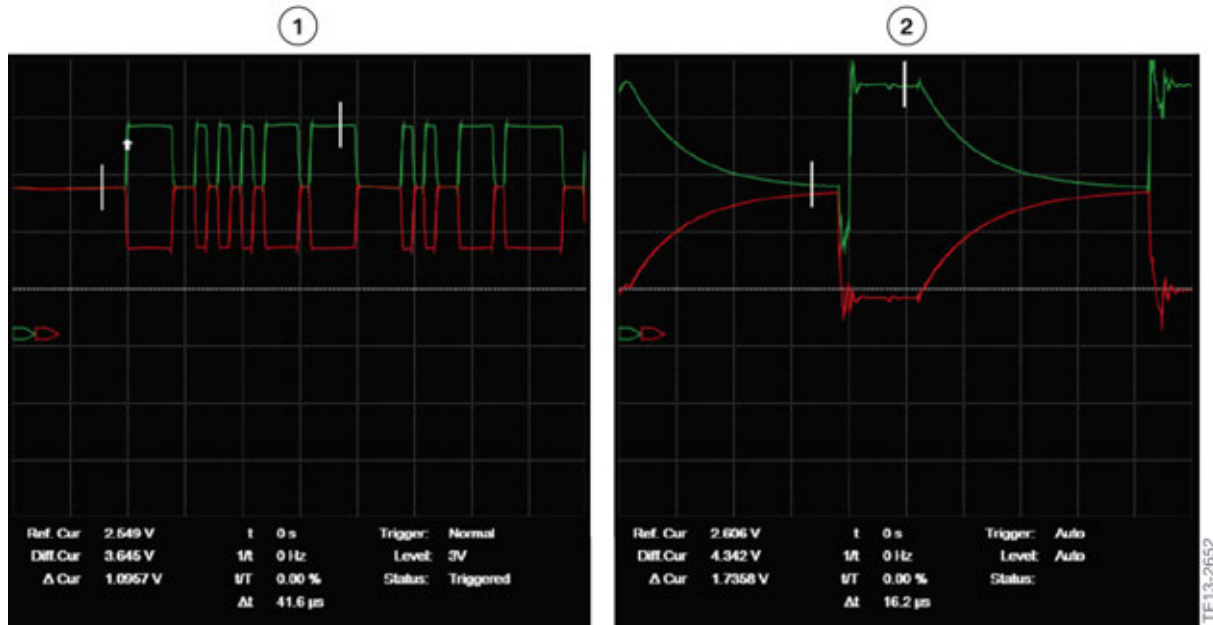

Oscilloscope holder K-CAN

Index	Explanation
1	Oscilloscope holder with active CAN terminator
2	Oscilloscope holder with disconnected or faulty CAN terminator

F48 General Vehicle Electronics

1. Vehicle Electrical System

Installation location

Depending on the equipment package, a maximum of four CAN terminators are installed in the F48.

The installation locations are shown in the following graphic:

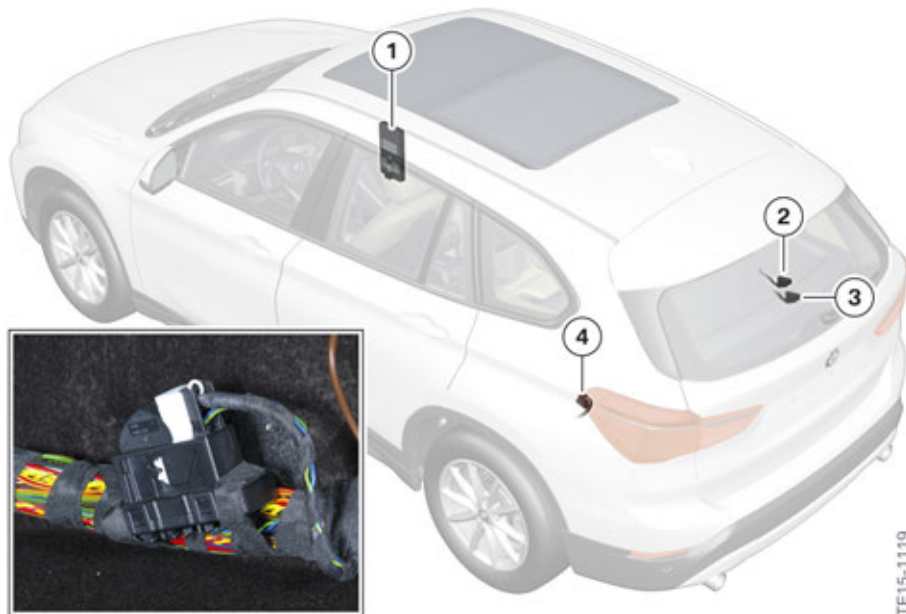

F48 installation location of CAN terminators

Index	Explanation
1	CAN terminator integrated in the Body Domain Controller
2	K-CAN3 terminator, rear right
3	K-CAN2 terminator, rear right
4	K-CAN4 terminator, rear left

1.2.2. PT-CAN

In the F48 the following PT-CANs are used:

- PT-CAN
- PT-CAN2

F48 General Vehicle Electronics

1. Vehicle Electrical System

1.2.3. FlexRay

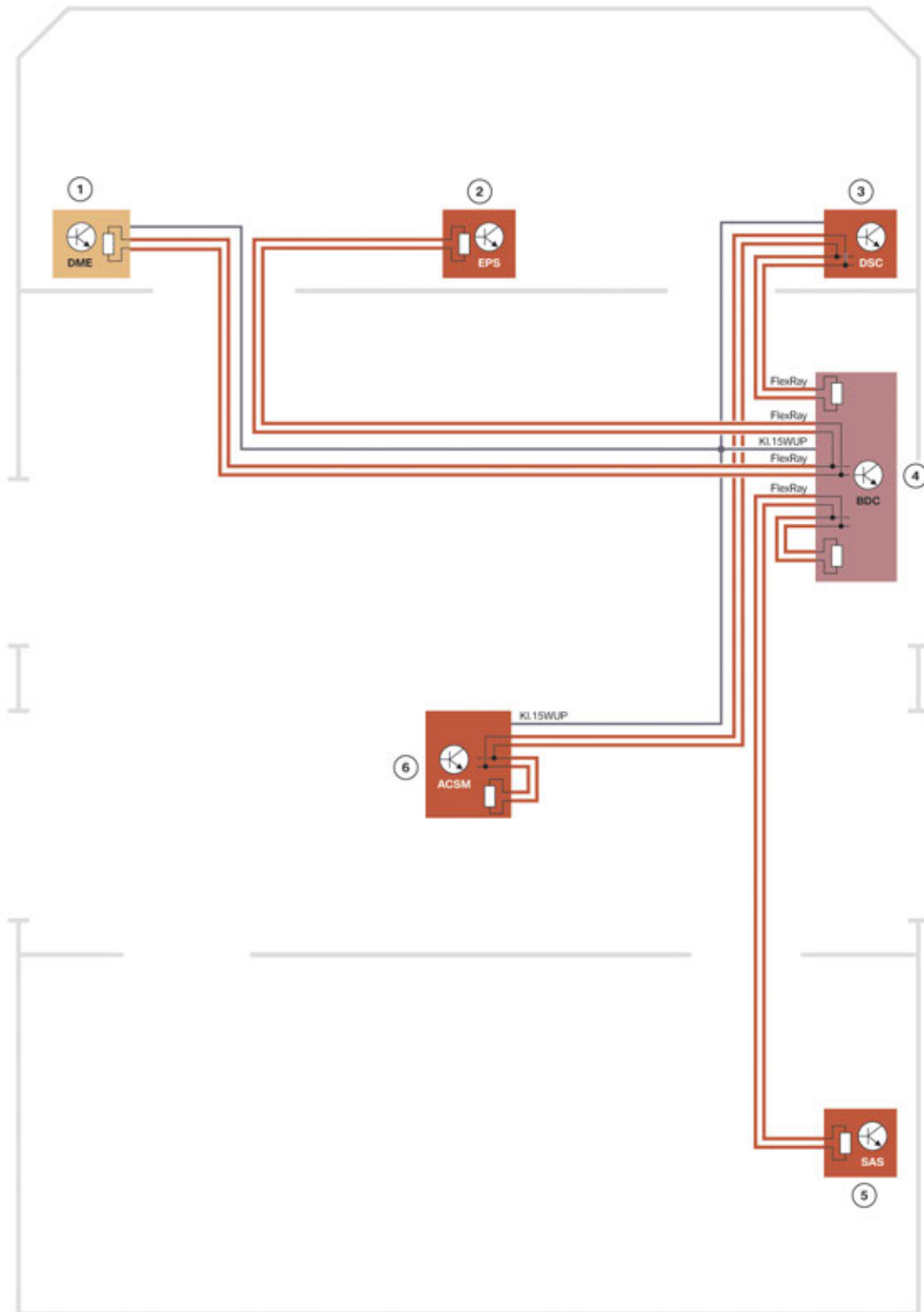

F48 system wiring diagram for FlexRay

TE13-0796

F48 General Vehicle Electronics

1. Vehicle Electrical System

Index	Explanation
1	Digital Motor Electronics (DME)
2	Electronic Power Steering (electromechanical power steering) (EPS)
3	Dynamic Stability Control (DSC)
4	Body Domain Controller (BDC)
5	Optional equipment system (SAS)
6	Crash Safety Module (ACSM)

FlexRay data bus topology

The FlexRay is shown in a simplified form in the data bus overview. The actual topology (star-shaped data bus topology) is shown in the graphic at the top.

The star coupler with four drivers is located in the Body Domain Controller (BDC). The FlexRay control units are connected to these bus drivers independent of their termination type.

Bus termination

As with most bus systems, resistors are also used for termination for the FlexRay to avoid reflections on the data lines at both ends of the data lines. The value of these terminating resistors is calculated from the data transfer speed and the cable lengths. The terminating resistors are located in the control units. In the F48 the terminating resistors have a value of 90 ohm (total resistance 45 ohm).



Use the vehicle wiring diagram for measuring the (de-energized) FlexRay data bus for the determination of the line or terminating resistor.

Signal properties

Electrical faults, which arise from incorrect cable routing, contact resistances, etc. may cause faulty data transfer.

F48 General Vehicle Electronics

1. Vehicle Electrical System

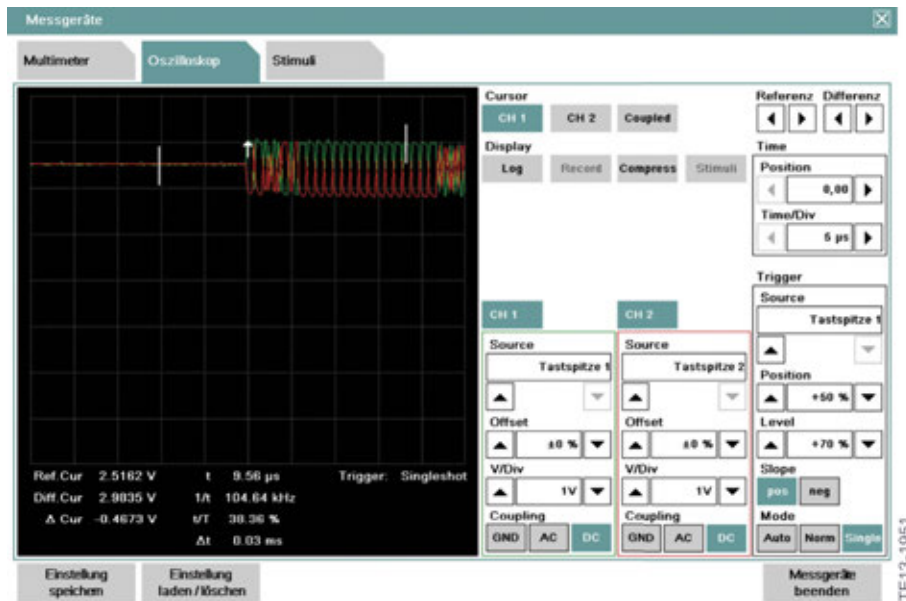

Oscilloscope presentation of FlexRay

The voltage ranges of the FlexRay bus system are:

- System ON - no bus communication 2.5 V
- High signal - 3.1 V (voltage signal increases to 600 mV and upwards)
- Low signal - 1.9 V (voltage signal decreases from 600 mV downwards)

The voltage values are measured against ground.

F48 General Vehicle Electronics

1. Vehicle Electrical System

Deterministic data transfer

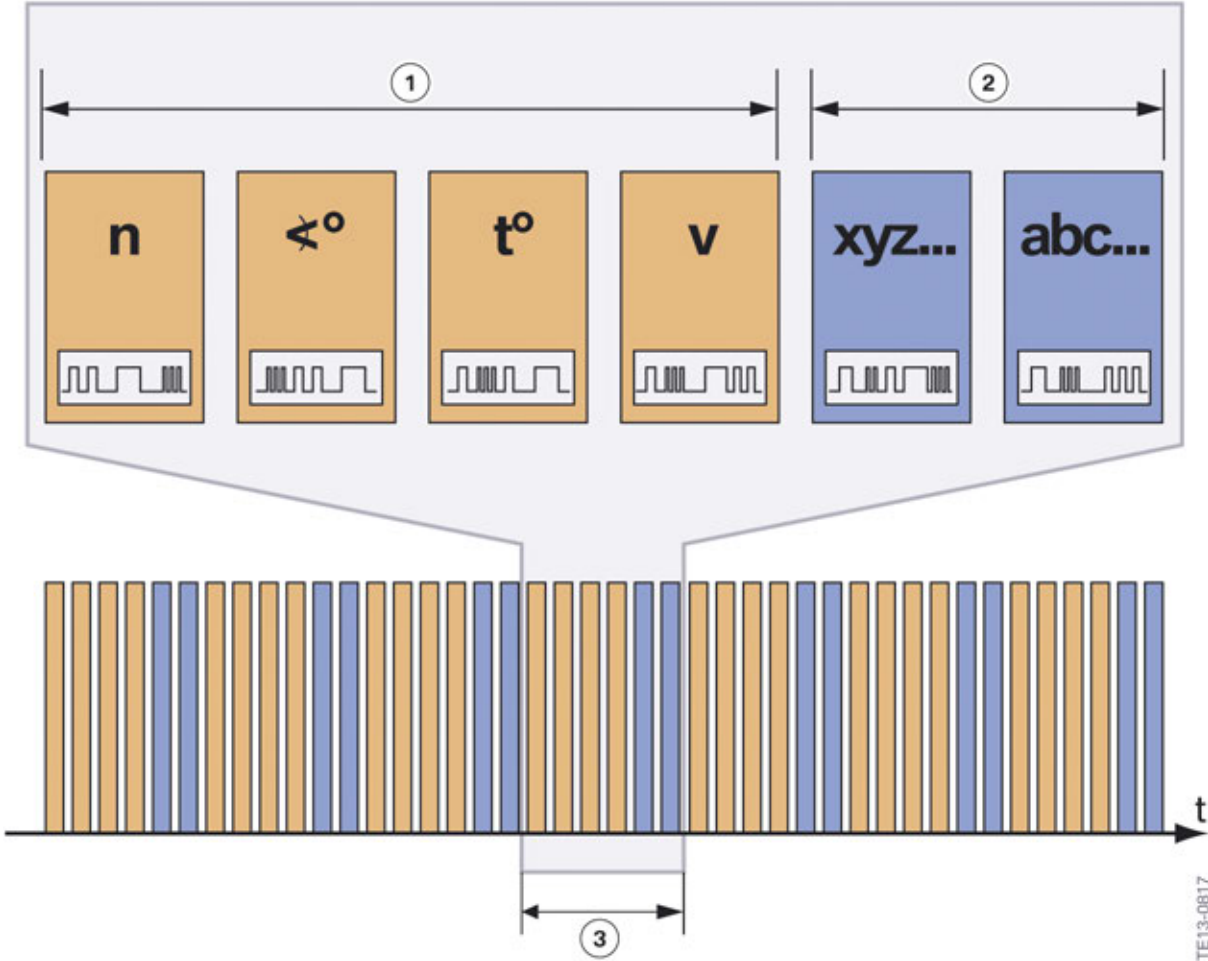

Deterministic data transfer

Index	Explanation
1	Time-controlled range of cyclical data transfer
2	Event-controlled range of cyclical data transfer
3	Cycle [5 ms overall cycle duration, of which 3 ms static (= time-controlled) and 2 ms dynamic (= event-controlled)]
n	Speed of rotation
α°	Angle
t°	Temperature
v	Speed
xyz... abc...	Event-controlled information
t	Time

F48 General Vehicle Electronics

1. Vehicle Electrical System

The CAN bus system is an event-controlled bus system. Data is transmitted when an event occurs. As these events have different priorities (e.g. ambient temperature has a lower priority than a DSC intervention, for example), the priorities are also sent in the bus message. The message with the higher priority is sent first. As the control unit still wants to send the message which has the lower priority, it frequently results in overloading in the bus systems.

The FlexRay works with so-called "time slots". With this method the messages are sent and are not controlled by events, but each control unit in the FlexRay network is assigned a fixed time slot in which it sends its message within a certain period. This time slot is synchronised with every restart of the data bus. The control units which synchronize the FlexRay are always labelled in the bus diagram with a "S" (see chapter 1.1).



The FlexRay can also be synchronised with the BMW diagnosis system in the event of a fault and corresponding fault code.

1.2.4. D-CAN

The D-CAN for the vehicle diagnosis has a data transfer rate of 500 kBit/s.

1.2.5. Ethernet

The Ethernet access is used for programming the entire vehicle.

In a F48 with navigation system the map update for the navigation can also be effected using the Ethernet interface.

1.2.6. MOST

In the F48 the Media Oriented System Transport (MOST) bus works at a data transfer rate of 22.5 MBit/s.

1.3. Sub-bus systems

1.3.1. Local interconnect network bus

Different data rates are used for the local interconnect network bus according to the information required. The data transfer rates of the local interconnect network bus in the F48 range from 19.2 kBit/s to 20.0 kBit/s.

Examples:

- 19.2 kBit/s FLEL, FLER
- 20.0 kBit/s remote control receiver

The Body Domain Controller is designed for the different data rates at the corresponding inputs.

F48 General Vehicle Electronics

1. Vehicle Electrical System

1.3.2. Local-CAN

With corresponding optional equipment, the Local Controller Area Network connects the optional equipment system (SAS) with the control unit for the camera-based driver support systems (KAFAS).

The Local Controller Area Network has a data transfer rate of 500 kBit/s.

1.3.3. USB

Depending on the equipment, the following USB connections are possible:

- from the headunit to the Telematic Communication Box (TCB)
- from the headunit to the telephone base plate
- from the headunit to the USB port

1.3.4. APIX

The central information display (CID) and the Head-Up Display (HUD) in the F48 are not connected to a vehicle data bus. Both control units are connected directly to the headunit via an APIX interface or the instrument cluster (KOMBI). APIX (Automotive Pixel Link) is a bit-serial data transfer system.

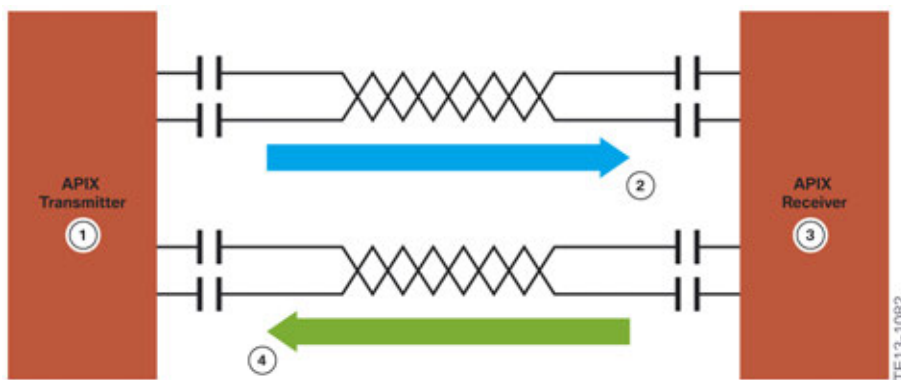

APIX

Index	Explanation
1	APIX transmitter
2	Message to be sent (max. 1 Gbit/s)
3	APIX receiver
4	Confirmation message (62.5 Mbit/s)

F48 General Vehicle Electronics

1. Vehicle Electrical System

1.4. Control units

This chapter contains information on control units,

- which are used for the first time in the F48
- which have been adapted for the F48

1.4.1. Complete overview

The installation locations of all the control units are shown in the following graphic.

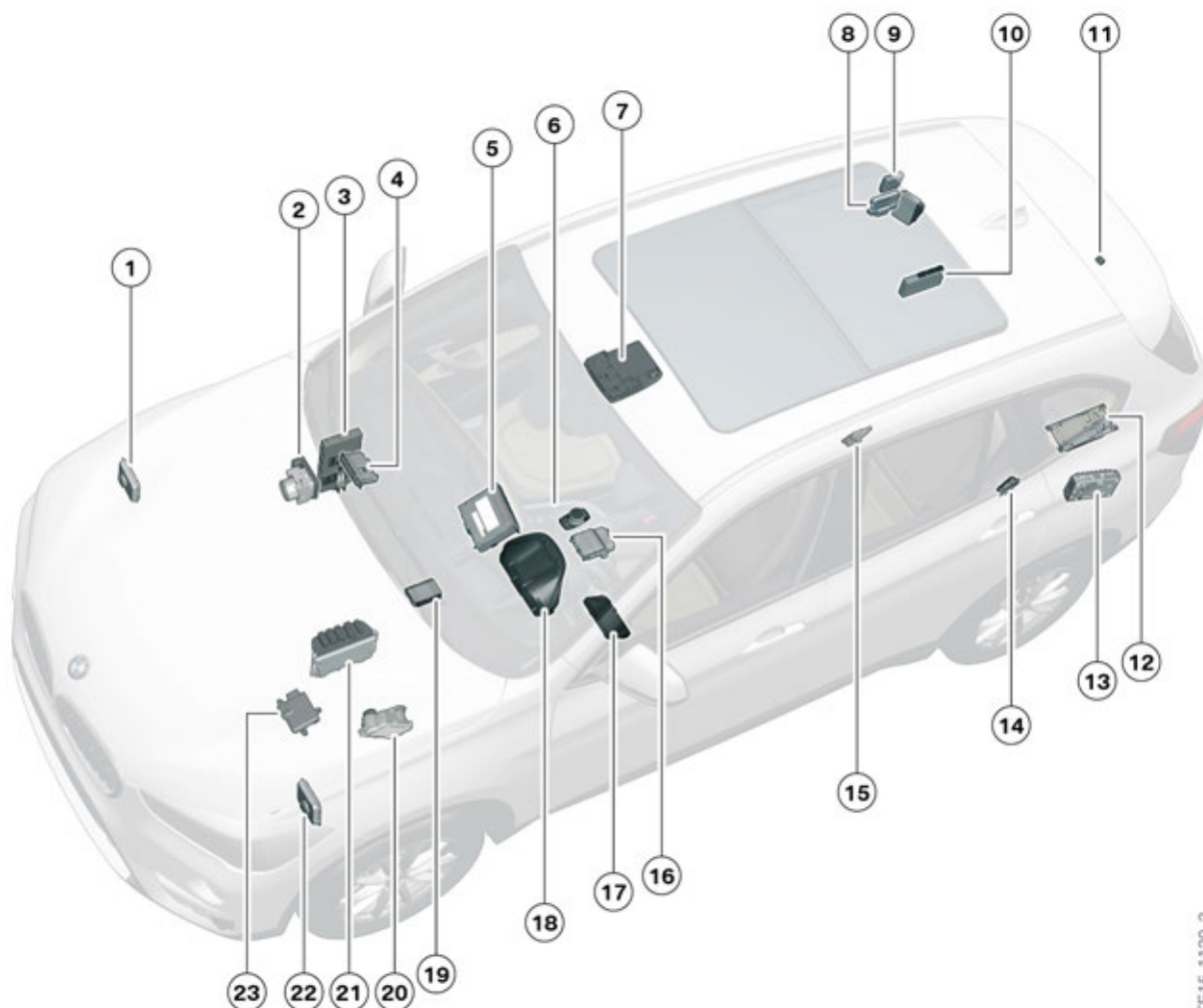

F48 Installation location of the control units

TE15-1120_2

F48 General Vehicle Electronics

1. Vehicle Electrical System

Index	Explanation
1	Frontal Light Electronics Right (FLER)
2	Dynamic Stability Control (DSC)
3	Body Domain Controller (BDC)
4	Camera-based driver support systems (KAFAS)
5	Headunit
6	Controller (CON)
7	Roof function center (FZD)
8	Optional equipment system (SAS)
9	Park Distance Control (PDC)/Parking Manoeuvring Assistant (PMA)
10	Automatic operation of tailgate (HKL)
11	Rear view camera (RFK)
12	Telematic Communication Box (TCB)
13	Amplifier (AMP)
14	Touchbox (TBX)
15	Longitudinal torque distribution (LMV)
16	Crash Safety Module (ACSM)
17	Driver's seat module (SMFA)
18	Instrument cluster (KOMBI)
19	Integrated heating and air conditioning (IHKA)
20	Electronic Power Steering (EPS)
21	Digital Engine Electronics (DME)
22	Electronic transmission control (EGS)
23	Frontal Light Electronics Left (FLEL)

F48 General Vehicle Electronics

1. Vehicle Electrical System

1.4.2. Body Domain Controller

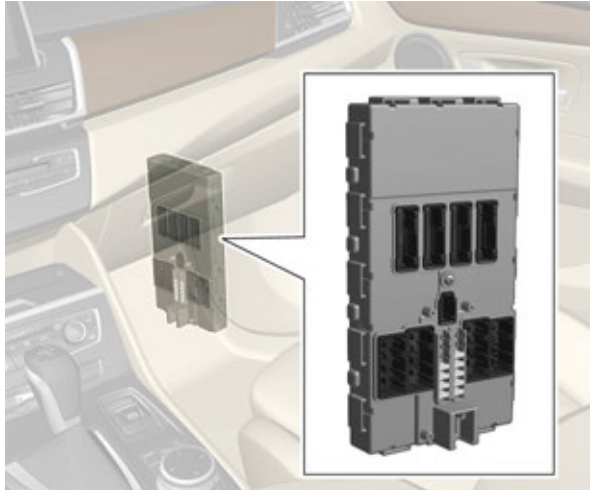

F48 Body Domain Controller (BDC)

The Body Domain Controller replaces the control units known from the F20/F30:

- Front Electronic Module (FEM)
- Rear Electronic Module (REM)

Further information on the Body Domain Controller is available in the ST1312 reference manual "F15 General Vehicle Electrical System".

1.4.3. Frontal Light Electronics

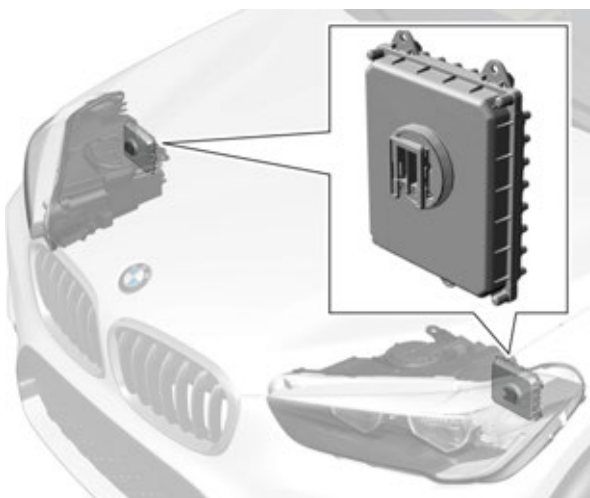

F48 Frontal Light Electronics Left and Right

The control units for the Frontal Light Electronics Left (FLEL) and Frontal Light Electronics Right (FLER) are installed in the left and right headlight for the LED headlight equipment.

F48 General Vehicle Electronics

1. Vehicle Electrical System

The Frontal Light Electronics includes:

- The activation of the LEDs in the corresponding headlight.
- The activation of the stepper motor for the headlight beam throw adjustment.

The control units FLEL and FLER are connected at the K-CAN3 and at the LIN.

1.4.4. TRSVC control unit

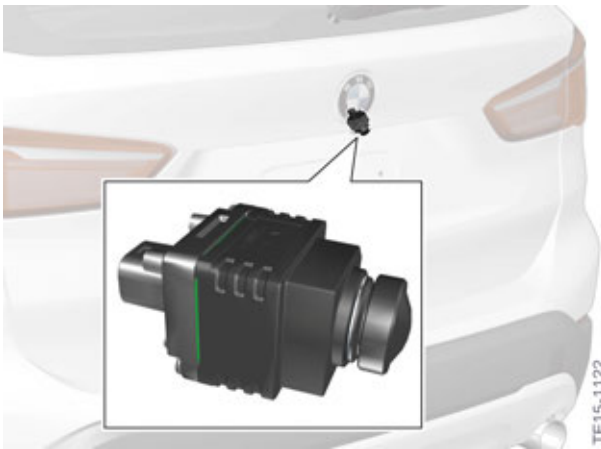

F48 TRSVC control unit

The Top Rear Side View Camera (TRSVC) control unit and the actual rear view camera are integrated in the one housing.

Only the rear view camera is offered for the F48.

The TRSVC control unit is connected at the K-CAN3. With the BMW diagnosis system the rear view camera is displayed as a TRSVC.

F48 General Vehicle Electronics

1. Vehicle Electrical System

1.4.5. Park Distance Control/Parking Maneuver Assistant



F48 Park Distance Control

Park Distance Control (PDC) assists the driver when maneuver in and out of a parking space. The current distance from an obstruction is indicated by acoustic signals and on a visual display.

In vehicles with Parking Maneuver Assistant (PMA), the sensors of the Park Distance Control (PDC) are evaluated by the Parking Maneuver Assistant control unit.

The customer can find the Parking Maneuver Assistant in the equipment list as Parking Maneuver Assistant (SA 5DP). The Parking Maneuver Assistant facilitates parking in gaps between cars parallel to the roadway.

The PDC/PMA control unit is connected at the K-CAN2.



In the BMW diagnosis system the PDC control unit is displayed as a PMA.

F48 General Vehicle Electronics

1. Vehicle Electrical System

1.4.6. Crash Safety Module



F48 Crash Safety Module

The function of the Advanced Crash Safety Module (ACSM) is to permanently evaluate all sensor signals in order to identify a crash situation. The ACSM evaluates the information from the sensors then forwards corresponding measures for selective activation of the necessary restraint systems.

The ACSM records the yaw rate and sends this information on the FlexRay data bus.

No additional yaw sensors are required for the following systems:

- Dynamic Stability Control (DSC)
- Navigation system

The ACSM is connected to the FlexRay.

1.4.7. Dynamic Stability Control

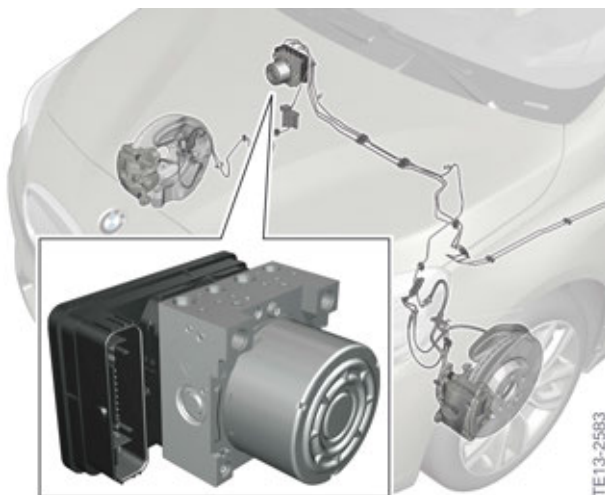

F48 Dynamic Stability Control

F48 General Vehicle Electronics

1. Vehicle Electrical System

The Dynamic Stability Control (DSC) also includes the tire pressure control function as well as the activation of the actuators of the EMF, in addition to the familiar functions for driving stability control, in the F48. These functions are described in more detail in the section "F48 Chassis and Suspension".

The DSC is connected at the FlexRay.

1.4.8. Optional equipment system

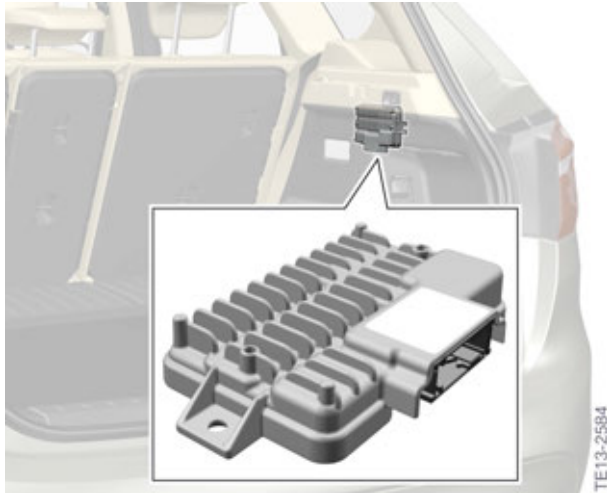

F48 Optional equipment system

The optional equipment system SAS control unit is not an element of the standard equipment. The vehicle must have at least one of the two optional equipment packages in order for an SAS to be installed:

- Dynamic Damper Control (SA 223)
- Driving Assistant (SA 5AS)

The optional equipment system (SAS) control unit provides a variety of driver assistance functions.

Possible functions:

- Collision warning with city braking function (SA 5AS)
- Pedestrian warning with city braking function (SA 5AS)
- Cruise control with braking function (as a sub-function of ACC Stop&Go (SA 5AS))
- Camera-based cruise control ACC Stop&Go (SA 5AT)
- Dynamic Damper Control (SA 223)

The image information required by the optional equipment system (SAS) is provided by the camera-based driver support systems (KAFAS) control unit.

The optional equipment system is connected at the FlexRay and via a Local Controller Area Network at the camera-based driver support system.

F48 General Vehicle Electronics

1. Vehicle Electrical System

1.4.9. Camera-based driver support systems

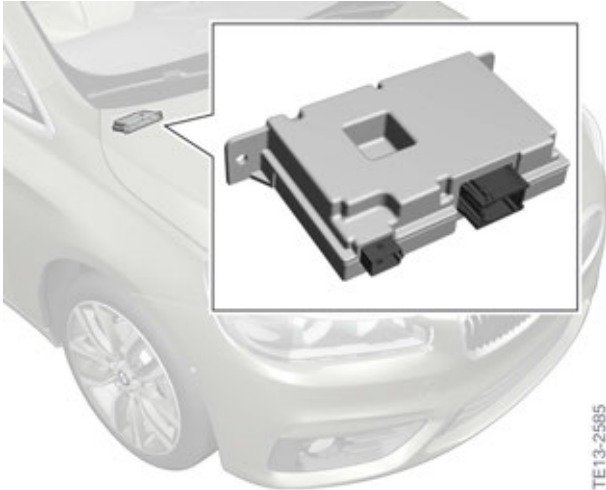

F48 Camera-based driver support systems

The control unit camera-based driver support systems (KAFAS) is required for the following optional equipment:

- Camera-based cruise control ACC Stop&Go
- Road sign recognition including no overtaking display
- Lane departure warning
- Collision warning
- Pedestrian warning with city braking function
- Collision warning with city braking function

The camera-based driver support system control unit is connected to the PT-CAN and to the optional equipment system (SAS) via a Local Controller Area Network.

F48 General Vehicle Electronics

1. Vehicle Electrical System

1.4.10. Automatic operation of tailgate

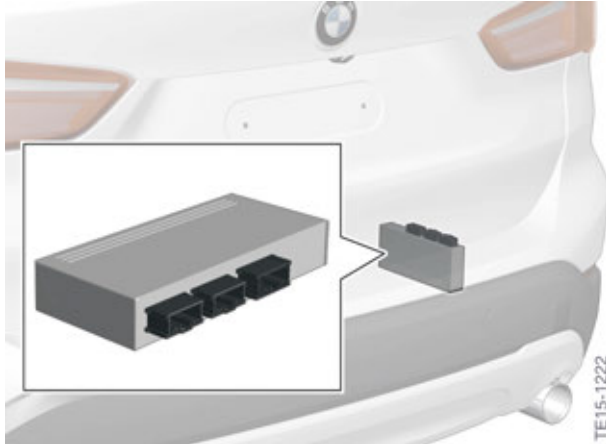

F48 control unit for automatic operation of tailgate

The automatic operation of tailgate (HKL) is responsible for the automatic tailgate opening and closing. The HKL monitors and activates the electric spindle drives for the tailgate activation.

The HKL is connected at the K-CAN2.

1.4.11. Longitudinal torque distribution

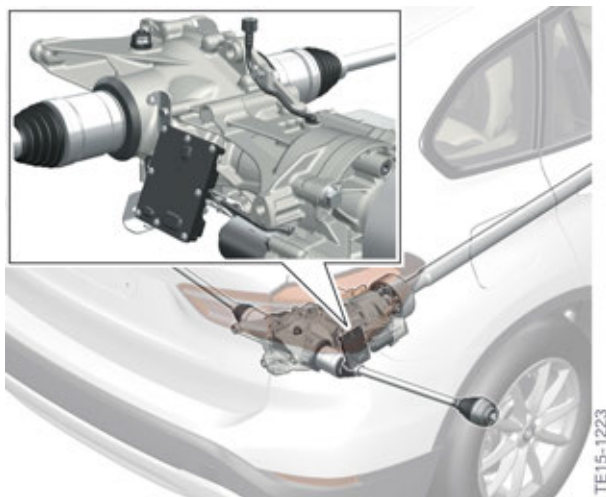

F48 control unit for longitudinal torque distribution

In the F48 with four-wheel drive, the longitudinal torque distribution distributes the drive torque variably to the front and rear axles.

The longitudinal torque distribution is connected at the K-CAN3.

F48 General Vehicle Electronics

2. Voltage Supply

2.1. Overview

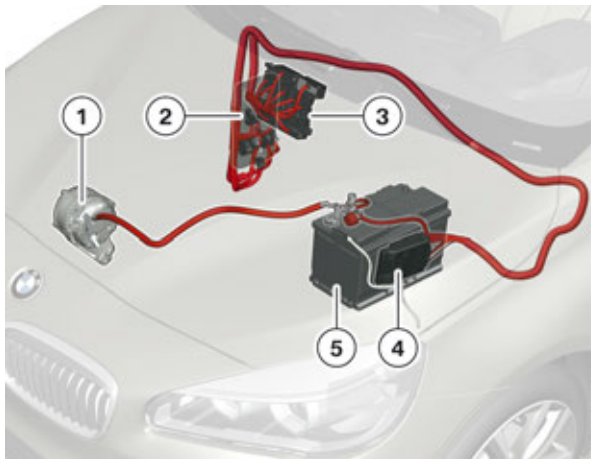

F48 Voltage supply

Index	Explanation
1	Alternator
2	Body Domain Controller (BDC)
3	Power distribution box, passenger compartment
4	Battery power distribution box
5	Battery

F48 General Vehicle Electronics

2. Voltage Supply

Index	Explanation
1	B+ jump start terminal point
2	Electric fan relay
3	Battery
4	Intelligent battery sensor
5	Battery power distribution box
6	Digital Engine Electronics (DME)
7	Alternator
8	Starter motor
9	Preheating control unit (only for diesel-engine cars)
10	Electronic Power Steering (EPS)
11	Dynamic Stability Control (DSC)
12	Power distribution box, passenger compartment
13	Body Domain Controller (BDC)
14	Blower motor, passenger compartment

2.2. Components

The voltage supply of the F48 is comprised of the following components:

- Battery
- Intelligent Battery Sensor (IBS)
- Battery power distribution box
- Power distribution box, passenger compartment
- Alternator
- Ground connections
- Body Domain Controller (BDC)

F48 General Vehicle Electronics

2. Voltage Supply

2.2.1. Battery



AGM battery

Depending on the equipment package, either a 70 Ah AGM battery or 80 Ah AGM battery is installed in the engine compartment in the F48.

2.2.2. Intelligent battery sensor



Intelligent battery sensor

Index	Explanation
1	Negative battery terminal
2	Intelligent battery sensor (IBS)
3	Battery earth lead

The intelligent battery sensor (IBS) records the following data of the battery:

- Voltage
- Current
- Pole temperature

The IBS performs the calculation and the evaluation of the information. The results are then forwarded to the superior control units via local interconnect network bus (DME and BDC).

F48 General Vehicle Electronics

2. Voltage Supply

The IBS has the same range of functions as with the predecessor models. The data transfer via the local interconnect network bus between the IBS, DEM and BDC is new. The IBS has a wake-up function.

The IBS continuously records relevant values for the battery indicators when the vehicle is in rest state. These can be read out for the diagnosis in the DME/DDE.



The IBS is fully functional directly after installation at the battery terminal (screw connection at negative battery terminal and connection of signal lines), i.e. the basic variables voltage, current and temperature can be called up straight away. However, the variables deduced for power management (battery condition, starting capability, etc.) must be recalculated and are therefore available with a delay.

2.2.3. Power distribution boxes

Power distribution box, passenger compartment

The power distribution box in the passenger compartment is located behind the glove box.

Some functions for which load relays are integrated in the BDC are protected directly in the BDC.

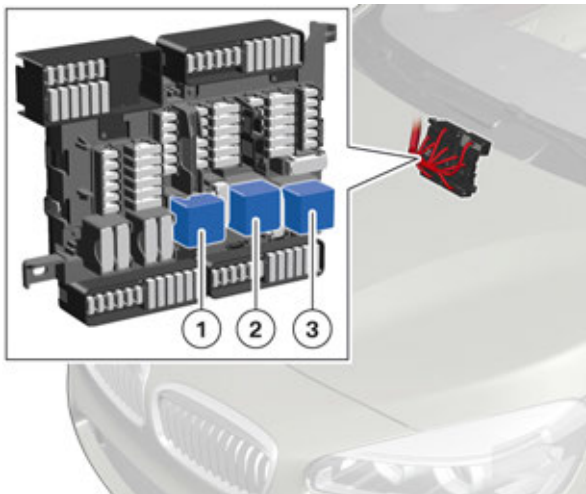

F48 Power distribution box, passenger compartment

Index	Explanation
1	Relay, terminal 15N
2	Relay, terminal 30B
3	Relay, terminal 30B

F48 General Vehicle Electronics

2. Voltage Supply

Battery power distribution box

The battery power distribution box supplies the following components with voltage:

- Power distribution box, passenger compartment
- Electric fan
- Electronic Power Steering (EPS)
- Dynamic Stability Control (DSC) (pump)
- Body Domain Controller (BDC)

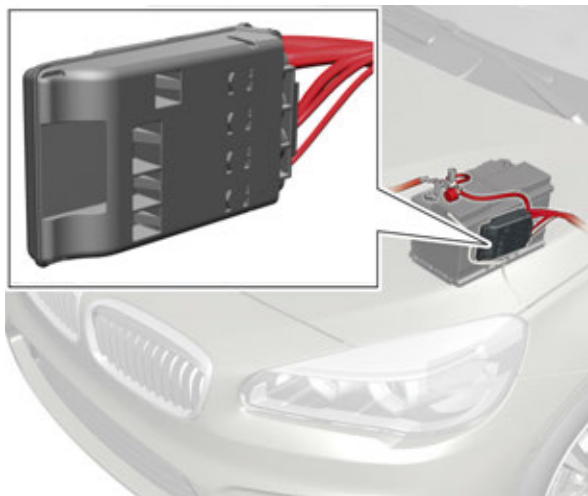

F48 Battery power distribution box

Power distribution box in Body Domain Controller

The following components are protected by fuses in the BDC power distribution box:

- Steering column switch cluster (SZL)
- Intelligent Safety button
- Light switch
- Rain-light-solar-condensation sensor (RLSBS)
- OBD2 interface
- Heating and air-conditioning units
- Outside door handle electronics (TAGE)
- Telematic Communication Box (TCB)
- Hands free tailgate activation
- Power windows
- Central locking system
- Heated rear window
- Rear wiper

F48 General Vehicle Electronics

3. Exterior Lights

3.1. Headlights

There are some new features in the area of the headlights for the F48.

The F48 receives halogen headlights in the basic equipment. LED headlights with extended scope (SA 5A4) are available as optional equipment.

Xenon headlights are not offered for the F48.

3.1.1. Halogen headlight

With the halogen headlights, the low-beam headlight, the high beam, as well as the turn indicator, are realized using bulbs. The side light and the daytime driving lights are generated via LEDs.

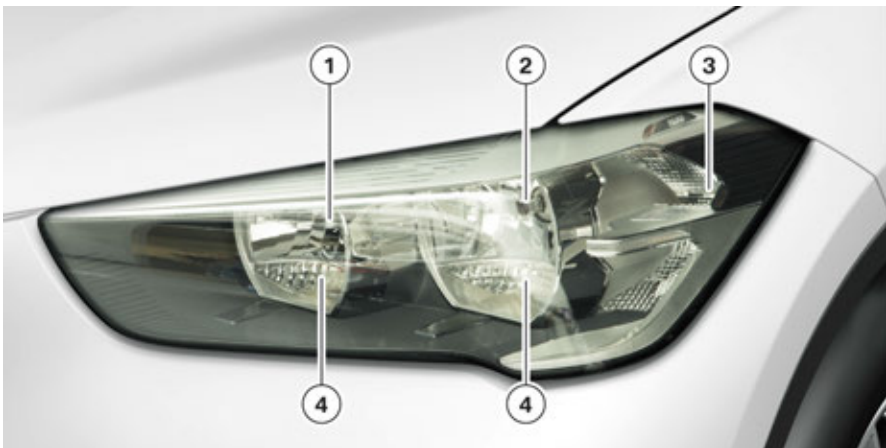

F48 Halogen headlight

Index	Explanation
1	Bulb for high beam
2	Bulb for low-beam headlight
3	Bulb for turn indicator
4	LEDs for side light/daytime driving lights

F48 General Vehicle Electronics

3. Exterior Lights

3.1.2. LED headlight with extended scope

The optional equipment LED headlight with extended scope (SA 5A4) also includes the adaptive light distribution, the cornering light and the static adaptive headlight, in addition to the functions of the LED headlight.

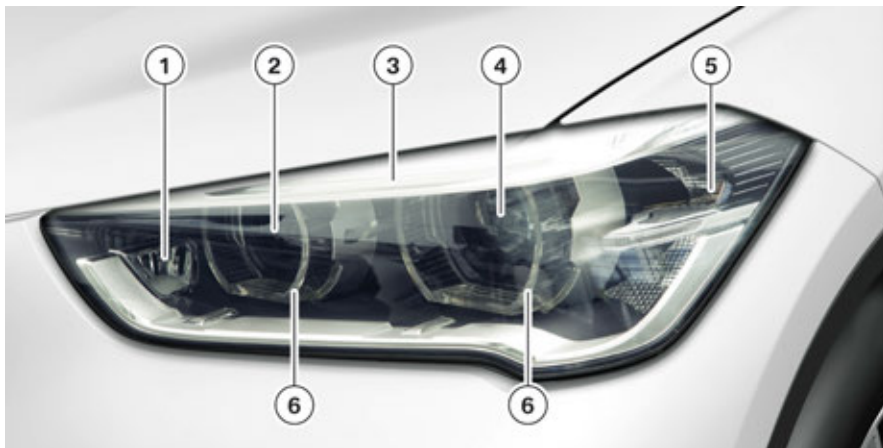

F48 LED headlight with extended scope

Index	Explanation
1	Cornering light
2	Design trim
3	Positioning light
4	Low-beam headlight/High-beam headlight
5	Bulb for turn indicator
6	Side lights/Daytime driving lights

Functions

The variable beam pattern offers improved adaptation of the beam pattern on the road situation. Depending on the speed driven, a distinction is made between the following beam patterns:

- Cornering light
- Adaptive headlight

Cornering light

The LED cornering light is integrated at the side in the headlight. During a slow journey (up to 45 km/h) the cornering light is either activated via the turn indicator or from a certain steering angle.

Static adaptive headlight

At speeds between 45 km/h and 70 km/h the cornering light is used as a "static Adaptive Headlight". The LEDs, which are responsible for the cornering light, are activated in order to illuminate the cornering area. This function is called a static Adaptive Headlight because the headlight is not moved.

F48 General Vehicle Electronics

3. Exterior Lights

Special features

In vehicles with LED headlights a ride height sensor for the automatic headlight beam throw adjustment is installed at the front and rear axle on the right side of vehicle.

For the F48 with LED headlight, a headlight cleaning system is **not** required. This could be waived due to compliance with all legal requirements.

The Frontal Light Electronics Left and Right (FLEL/FLER) is installed at the rear side of the LED headlight and controls the following functions:

- Low-beam headlight
- High beam
- Headlight flasher
- Headlight beam angle adjustment
- Cornering lights

In addition, the FLE controls the temperature control in the LED headlight. The values of two temperature sensors at the heat sink serve as input signals. After switching off the lighting function an after-run of the fans of up to 60 seconds is possible. In the temperature control there is also a function for the de-icing of the LED headlight.

In the case of a failure of a temperature sensor the fans are switched on at full power to protect the components in the LED headlight. The data from the FLE is transferred to the Body Domain Controller (BDC) via the local interconnect network bus for the diagnosis of the fans and temperature sensors.



For legal reasons (approval of light technology), the LED headlight obtains a forced connection for the rain-light-solar-condensation sensor.

F48 General Vehicle Electronics

3. Exterior Lights

System wiring diagram

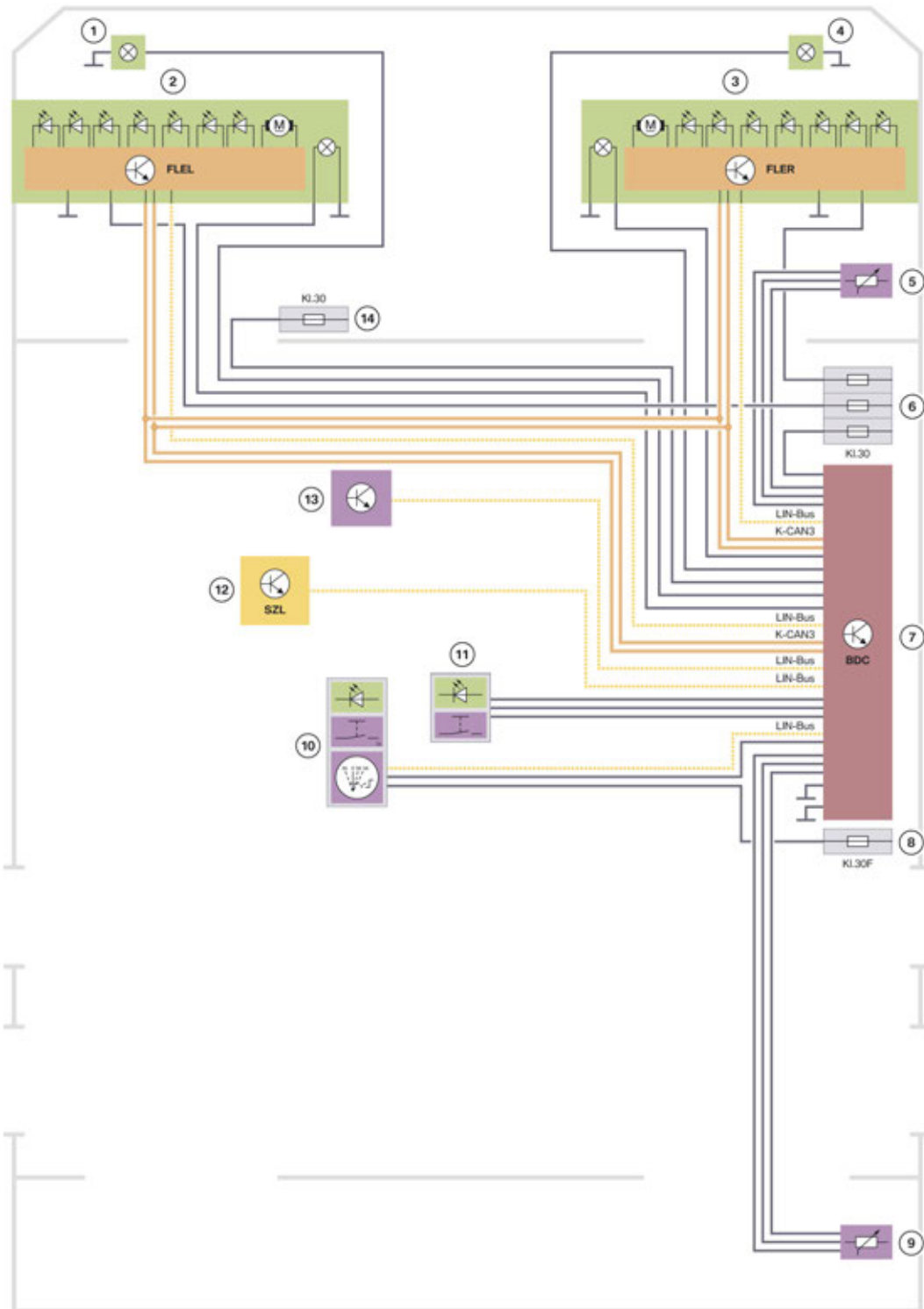

F48 system wiring diagram for the LED headlight

TE13-2594

F48 General Vehicle Electronics

3. Exterior Lights

Index	Explanation
1	Left fog light
2	LED headlight with extended scope, left
3	LED headlight with extended scope, right
4	Right fog light
5	Ride height sensor, front right
6	Fuses in the power distribution box in the passenger compartment
7	Body Domain Controller (BDC)
8	Fuse in the Body Domain Controller
9	Ride height sensor, rear right
10	Light switch
11	Hazard warning switch/Intelligent Safety button
12	Steering column switch cluster (SZL)
13	Rain-light-solar-condensation sensor (RLSBS)
14	Fuse in the power distribution box, battery

3.1.3. fog lights



F48 fog lights

The F48 comes with fog lights as standard equipment. Halogen lights are used inside the fog lights.

F48 General Vehicle Electronics

3. Exterior Lights

3.2. Rear lights

Depending on equipment, two different versions of rear lights are used in the F48.

3.2.1. In vehicles with halogen headlights

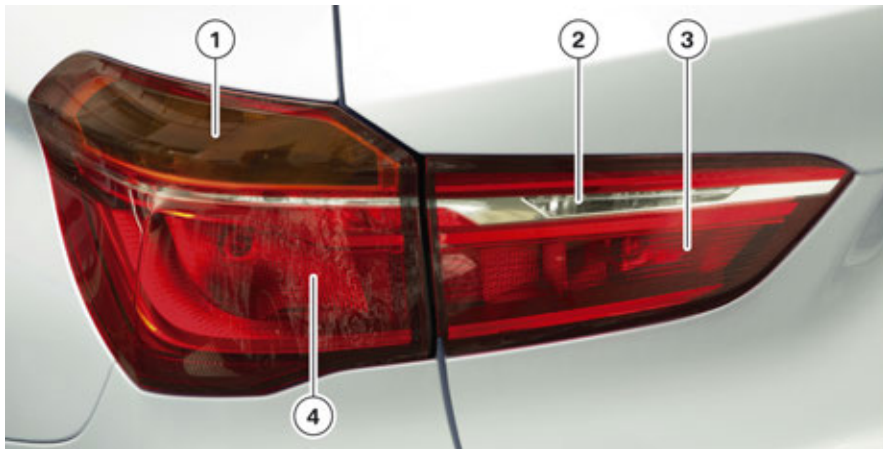

F48 with halogen headlights

Index	Explanation
1	Turn indicator
2	Reversing light
3	Tail light/fog light
4	Tail light/brake light

Only bulbs are used in the rear lights for vehicles with halogen headlights.

F48 General Vehicle Electronics

3. Exterior Lights

3.2.2. Vehicles with LED headlights

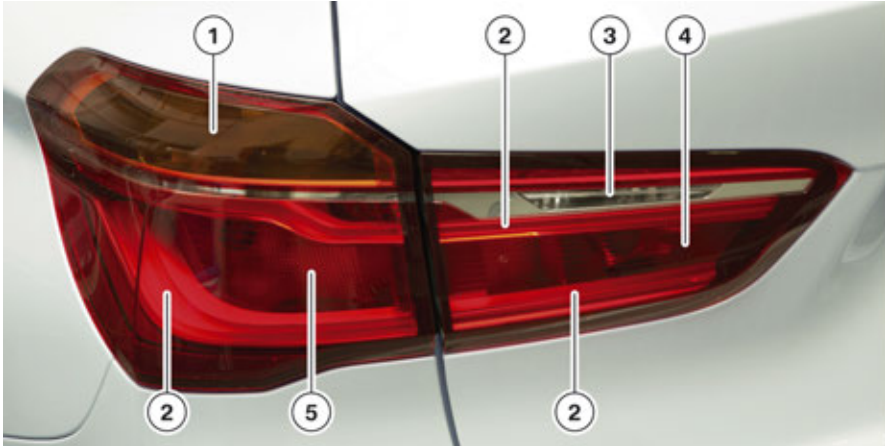

F48 with LED headlights

Index	Explanation
1	Turn indicator
2	Tail light (LED)
3	Reversing light
4	Fog light
5	Brake light

In conjunction with LED headlights (SA 5A4), the tail light function in the rear light is performed with LEDs.

F48 General Vehicle Electronics

4. Interior Lighting

The F48 is offered with two different concepts of interior lighting.

- Basic
- Lights package (SA 563)

Other contour lights can also be installed with the optional equipment Sport Line (SA 7AC) and xLine (SA 7HW).

F48 General Vehicle Electronics

4. Interior Lighting

4.1. System wiring diagram

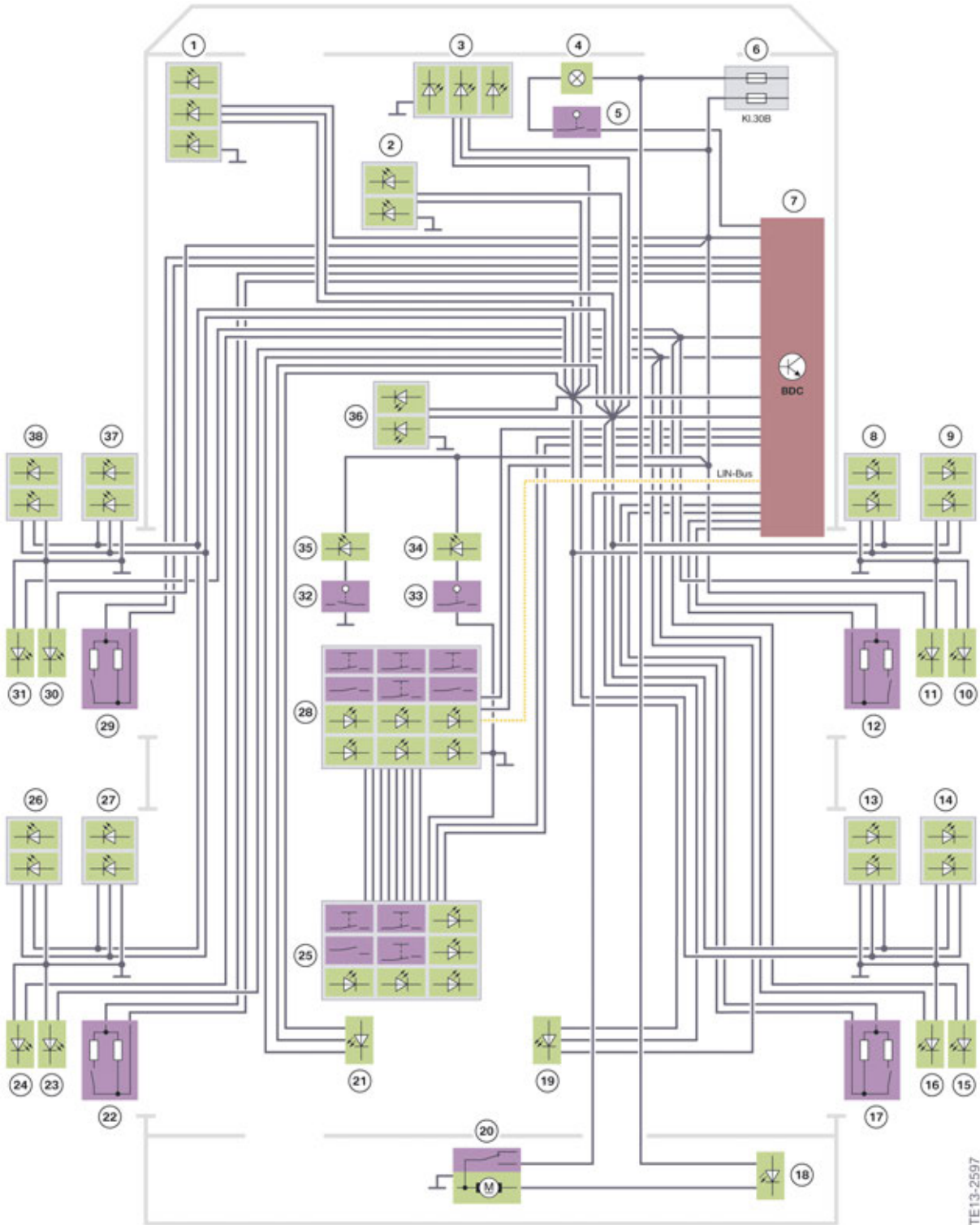

TE13-2597

F48 system wiring diagram for interior lighting with light package (SA 563)

F48 General Vehicle Electronics

4. Interior Lighting

Index	Explanation
1	Footwell light, front left
2	Lighting, decorative strip on passenger's side
3	Footwell light, front right
4	Glove box light
5	Glove box switch
6	Fuses in the power distribution box in the passenger compartment
7	Body Domain Controller (BDC)
8	Door pocket lighting, front right
9	Door pocket lighting, front right
10	Outside door handle light, front right
11	Door entry lighting, front right
12	Door contact, front right
13	Door pocket lighting, rear right
14	Door pocket lighting, rear right
15	Outside door handle light, rear right
16	Door entry lighting, rear right
17	Door contact, rear right
18	Luggage compartment light
19	Footwell light, rear right
20	Tailgate lock with switch
21	Footwell light, rear left
22	Door contact, rear left
23	Door entry lighting, rear left
24	Outside door handle light, rear left
25	Interior light unit, rear
26	Door pocket lighting, rear left
27	Door pocket lighting, rear left
28	Front interior light unit
29	Door contact, front left
30	Door entry lighting, front left
31	Outside door handle light, front left
32	Switch for make-up mirror light, left
33	Switch for make-up mirror light, right
34	Make-up mirror light, right

F48 General Vehicle Electronics

4. Interior Lighting

Index	Explanation
35	Make-up mirror light, left
36	Door pocket lighting, front left
37	Lighting, center stack
38	Door pocket lighting, front left

F48 General Vehicle Electronics

5. Heating/Air Conditioning Systems

In the F48 one variant of the heating and air conditioning systems are available for the US:

- IHKA 2/1 zones

In the zone specification the first number denotes the number of controllable temperature zones (temperature selector wheels) and the second number denotes the number of controllable airflow volume and air distribution zones (separate fan settings).



For the air-conditioning system of the F48 the refrigerant R134a is used.

Other equipment for the F48:

- Seat heating for driver and front passenger (SA 494)
- Steering wheel heating (SA 248)
- Mirror heating (standard equipment)
- Heated washer jets (standard equipment)

5.1. Components and systems

5.1.1. Integrated automatic heating and air conditioning

An automatic air-conditioning system is available for the F48 as optional equipment (SA 534).

Contents:

- Two-zone automatic air conditioning
- 5 climate controls (automatic programs) for setting the desired intensity
- Condensation sensor
- Automatic air recirculation control sensor (NOx, CO) for automatic air recirculation function
- Combination filter with activated carbon for fresh air and air recirculation function
- Personal Profiles are stored in a key-dependent way
- MAX AC function (maximum cooling in passenger compartment)
- Defrost function (quick removal of condensation)
- Fresh air vent in the rear passenger compartment

F48 General Vehicle Electronics

5. Heating/Air Conditioning Systems

Control panel



F48 IHKA control panel

Index	Explanation
1	Defrost window glass and remove condensation
2	Temperature, left
3	Automatic program
4	Switch off system
5	Amount of air, AUTO intensity
6	Display
7	SYNC program
8	Maximum cooling
9	Temperature, right
10	Air conditioning function
11	Automatic air recirculation control/air recirculation function
12	Seat heating, right
13	Air distribution
14	Seat heating, left
15	Passenger compartment temperature sensor
16	Heated rear window

F48 General Vehicle Electronics

5. Heating/Air Conditioning Systems

Components

Sensors and actuators which are connected to the Body Domain Controller (BDC) control unit are involved in the function of the heating and air-conditioning system in the F48:

- **Pressure sensor**
The BDC evaluates the pressure sensor signal and makes it available to the IHKA control unit via the K-CAN4.
- **Blower**
The IHKA request is sent via the LIN bus to the blower.
- **Air conditioning compressor**
The air conditioning compressor is controlled by the BDC by means of a pulse-width-modulated signal. The BDC can also actuate the air conditioning compressor clutch. However, the request is always made by the IHKA.
- **Automatic air recirculation control sensor**
The automatic air recirculation control sensor is read by the BDC via a local interconnect network bus. The IHKA assumes the automatic air flap control, which communicates with the BDC via K-CAN4.
- **Rain-light-solar-condensation sensor (RLSBS)**
The rain-light-solar-condensation sensor communicates with the BDC via a local interconnect network bus.

F48 General Vehicle Electronics

5. Heating/Air Conditioning Systems

System wiring diagram

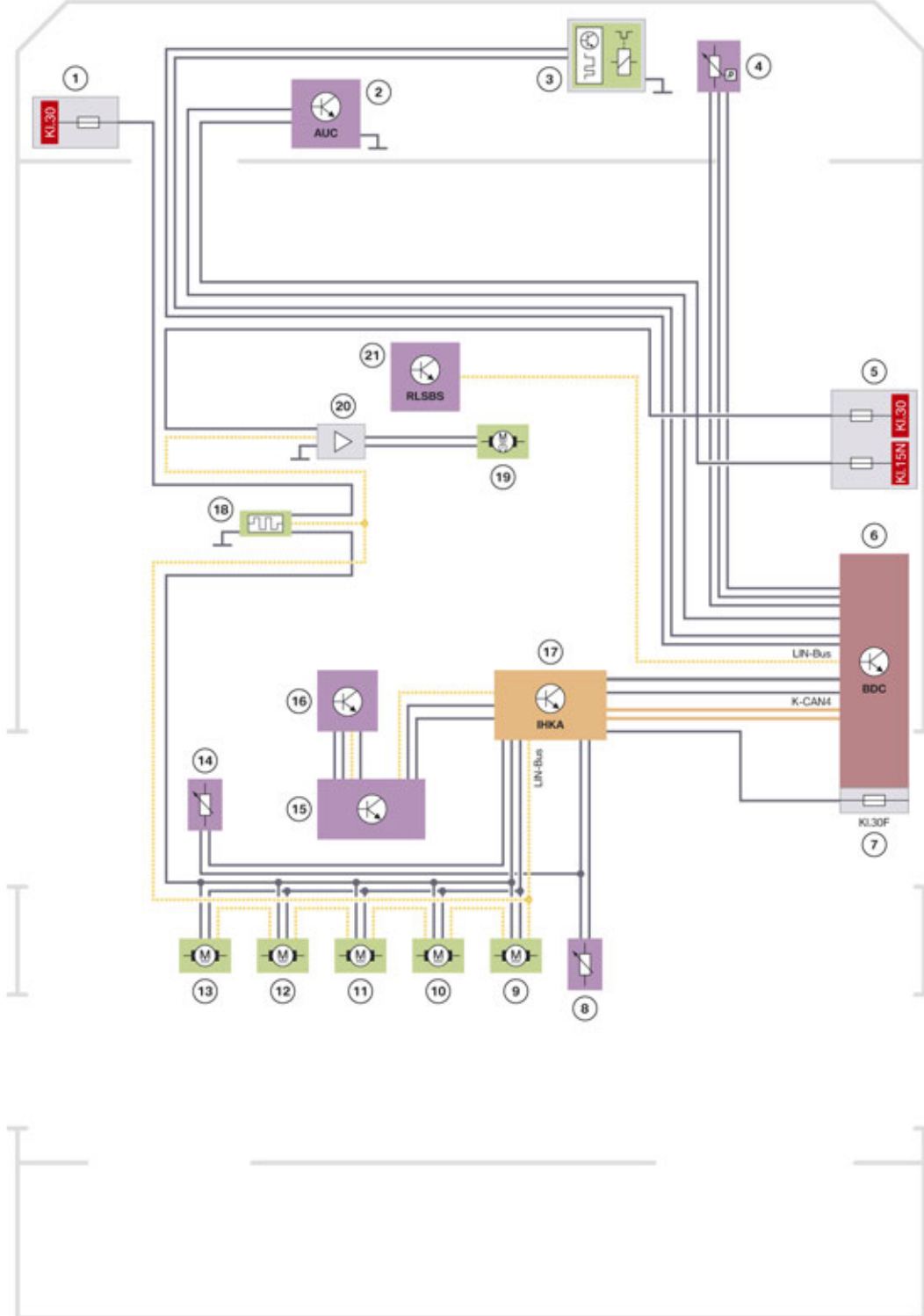

TE13-2602

F48 system wiring diagram for IHKA

F48 General Vehicle Electronics

5. Heating/Air Conditioning Systems

Index	Explanation
1	Battery power distribution box
2	Automatic air recirculation control sensor
3	Air conditioning compressor
4	Refrigerant pressure sensor for switching off in the event of excess pressure in the refrigerant circuit
5	Fuses in the power distribution box in the passenger compartment
6	Body Domain Controller (BDC)
7	Fuse in the power distribution box, BDC
8	Temperature sensor for evaporator
9	Stepper motor, blending flap, left
10	Stepper motor, blending flap, right
11	Stepper motor, fresh air/air recirculation function
12	Stepper motor, flaps, footwell ventilation, left and right
13	Stepper motor flaps for defrost function
14	Ventilation temperature sensor, left
15	Audio operating facility
16	Operating unit for standard heating and air conditioning
17	Integrated heating and air conditioning (IHKA)
18	Electric auxiliary heater (only for diesel engines)
19	Blower motor, passenger compartment
20	Blower output stage, local interconnect network bus control
21	Rain-light-solar-condensation sensor (RLSBS)

F48 General Vehicle Electronics

5. Heating/Air Conditioning Systems

5.1.2. Heating and air-conditioning unit

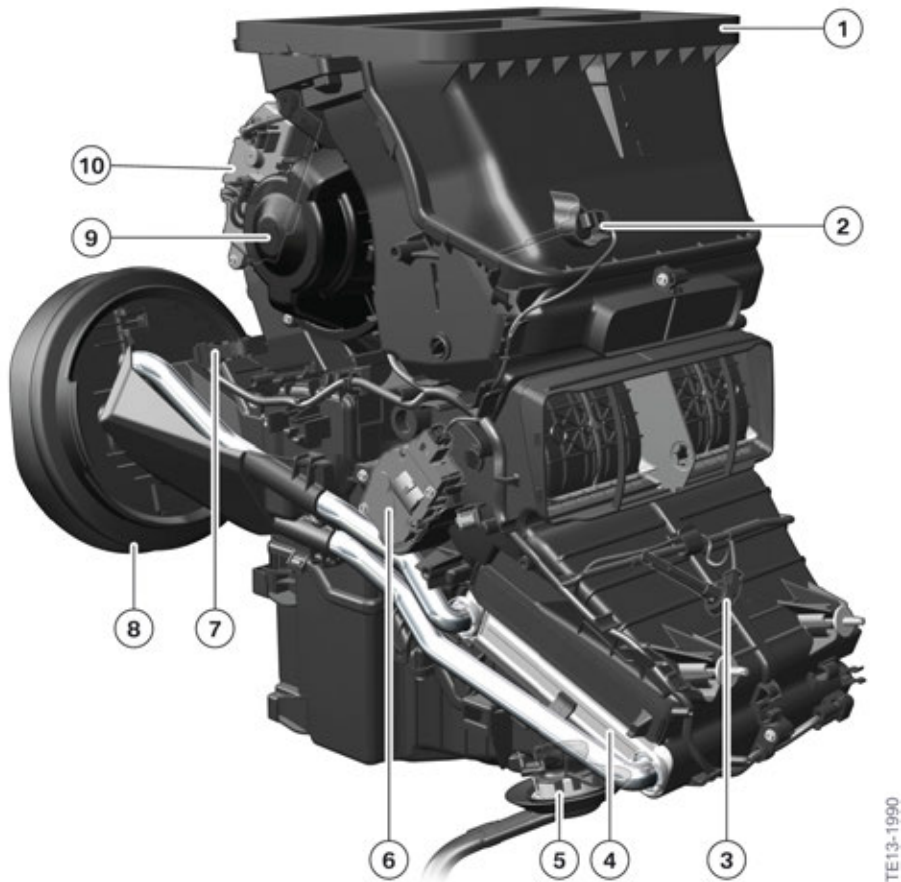

F48 Heating and air-conditioning unit

Index	Explanation
1	Air vent, top
2	Temperature sensor, center vent
3	Temperature sensor, footwell air outlet
4	Heat exchanger
5	Discharge of condensation from the heating and air-conditioning unit
6	Stepper motor for blending flap
7	Connector at the control unit for integrated heating / air-conditioning regulation/IHKA
8	Sleeve, bulkhead
9	Blower motor
10	Blower output stage

F48 General Vehicle Electronics

5. Heating/Air Conditioning Systems

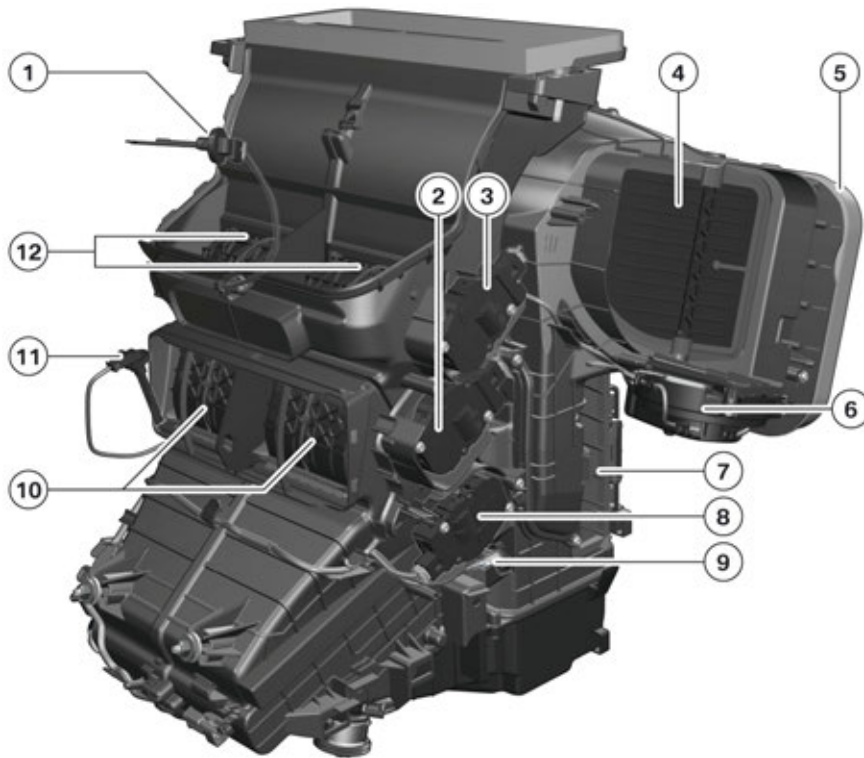

TE13-0569

F48 Heating and air-conditioning unit

Index	Explanation
1	Temperature sensor, center vent
2	Stepper motor for footwell air outlet, left and right
3	Stepper motor for defrost function
4	Recirculated air flap
5	Ambient air intake area at the bulkhead
6	Stepper motor for recirculated air flap (with kinematics control)
7	Service flap of two microfilters
8	Stepper motor for blending flap
9	Evaporator temperature sensor
10	Ventilation flaps, air vent at feet
11	Temperature sensor, footwell air outlet
12	Air flaps, center vent

F48 General Vehicle Electronics

5. Heating/Air Conditioning Systems

5.1.3. Microfilter

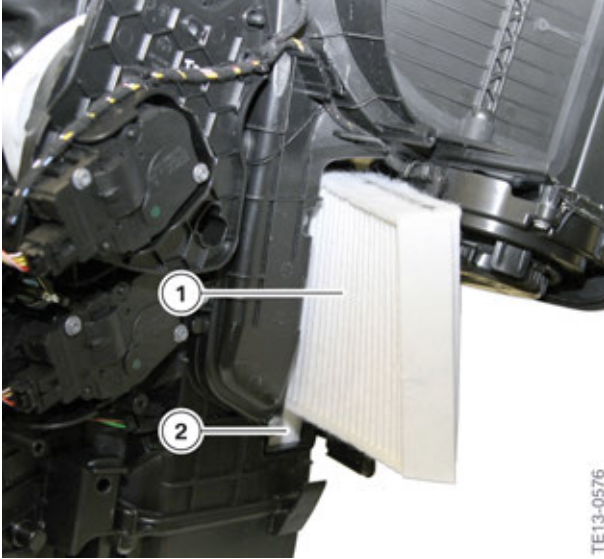

F48 heating and air-conditioning unit, replacement of microfilter

Index	Explanation
1	Upper microfilter
2	Lower microfilter



F48 heating and air-conditioning unit, replacement of microfilter

F48 General Vehicle Electronics

5. Heating/Air Conditioning Systems



Two microfilters are installed in the F48. The BMW repair instructions must be followed for the replacement of the microfilters.

5.1.4. Air/Water separation (Venturi adapter)



F48 air/water separation (Venturi adapter)

So that no water enters the heating and air-conditioning unit, a cover (Venturi adapter) is installed before the air intake in the engine compartment.

The fresh air drawn in is accelerated by the design of the Venturi adapter and redirected 90°. Through this process the water separates at the cover and then drains off downwards.

F48 General Vehicle Electronics

5. Heating/Air Conditioning Systems

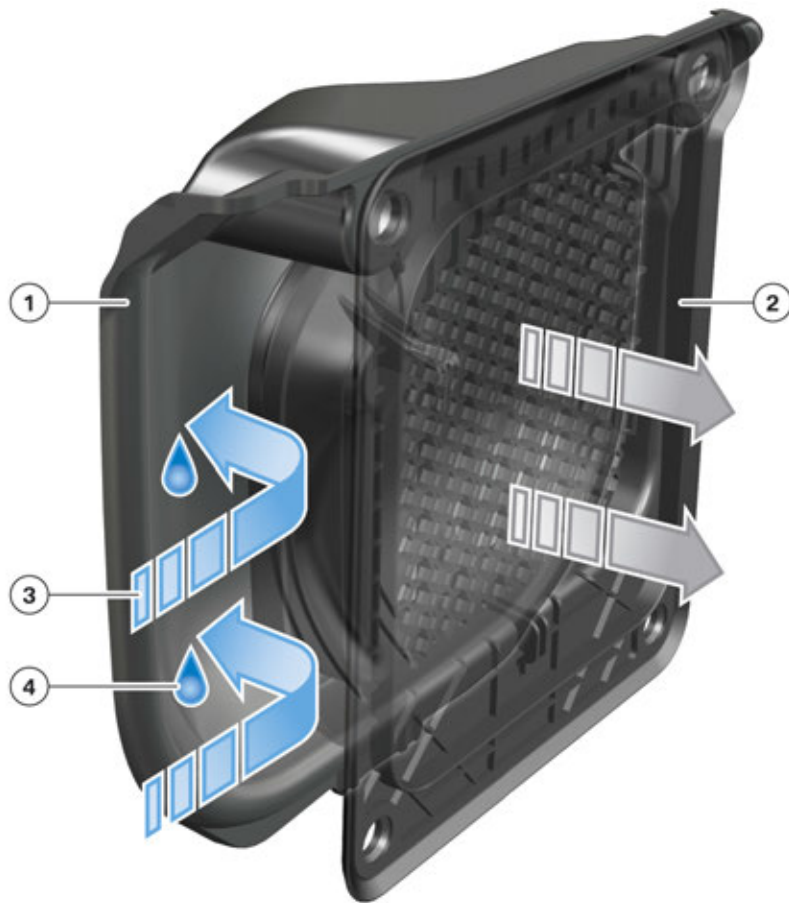

TE14-0542

F48 function of air/water separation (Venturi adapter)

Index	Explanation
1	Cover
2	Dirt trap
3	Fresh air drawn in
4	Separated condensate

F48 General Vehicle Electronics

5. Heating/Air Conditioning Systems

5.1.5. ECO PRO mode of heating and air conditioning program

In ECO PRO mode the heating and air conditioning functions can be configured. This also contributes to a reduction in fuel consumption thanks to the intelligent heating and air-conditioning management.

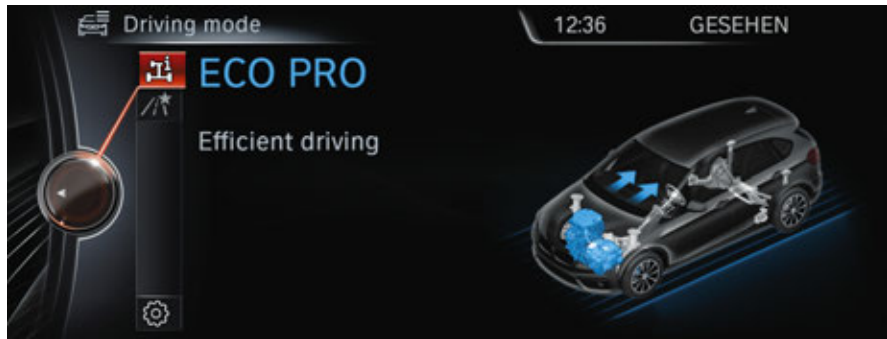

F48 ECO PRO mode



The cooling system cannot be filled or bled in ECO PRO mode. Observe the BMW repair instructions.

F48 General Vehicle Electronics

6. Locking and Security Functions

In the F48 there are two distinct systems concerned with vehicle access:

- Basic access, central locking system
- Comfort Access (SA 322)

The entire locking and security function of the F48 is integrated in the Body Domain Controller (BDC).

F48 General Vehicle Electronics

6. Locking and Security Functions

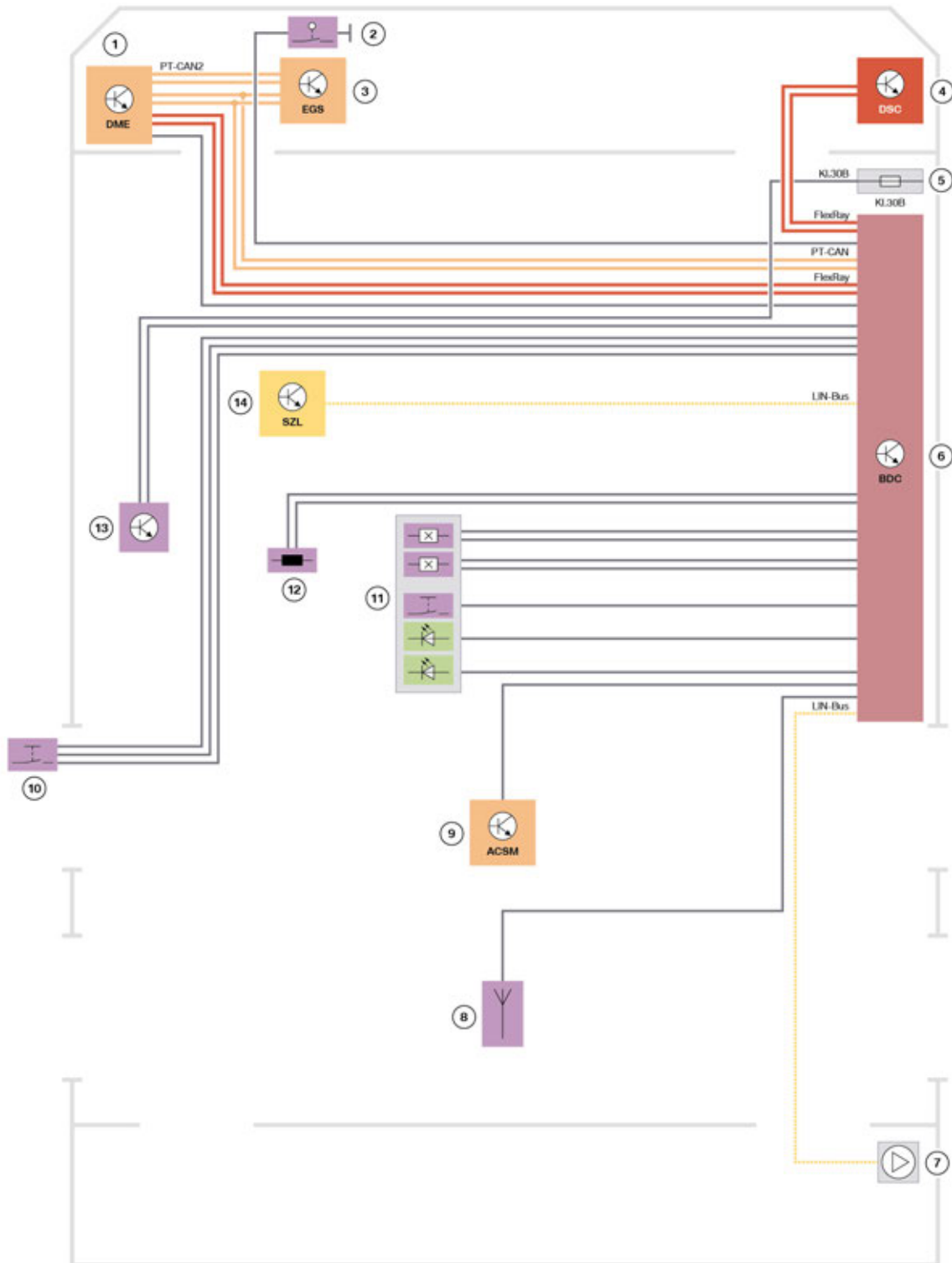

F48 system wiring diagram for locking and security functions

TE13-0815_2

F48 General Vehicle Electronics

6. Locking and Security Functions

Index	Explanation
1	Digital Engine Electronics (DME)
2	Engine compartment lid contact switch
3	Electronic transmission control (EGS)
4	Dynamic Stability Control (DSC)
5	Fuse in the power distribution box in the passenger compartment
6	Body Domain Controller (BDC)
7	Remote control receiver
8	Interior antenna
9	Advanced Crash Safety Module (ACSM)
10	Central locking button, left
11	START-STOP button
12	Ring antenna (transponder coil)
13	Clutch switch (only for vehicles with manual gearbox)
14	Steering column switch cluster (SZL)

6.1. Overview of functions

The following locking and security functions are integrated in the Body Domain Controller:

- Comfort Access
- Central locking system
- Terminal control
- Electronic immobilizer

F48 General Vehicle Electronics

6. Locking and Security Functions

6.1.1. Remote control receiver

The remote control receiver is installed in the luggage compartment on the right.

The radio signal received by the remote key is forwarded by the remote control receiver via a local interconnect network bus to the BDC.



F48 Installation location of the remote control receiver

6.2. Central locking system

The function of the central locking system of the F48 is based on that of current BMW models. With the introduction of the BDC, all relevant functions for the central locking system are handled by one control unit. The function is as follows:

- The radio signal from the ID transmitter is received by the remote control receiver.
- The signal causes the BDC to activate the central locking system and the interior lighting.
- The BDC evaluates the status of all door contacts. In this way, for example, the vehicle can be prevented from being locked while the driver's door is open.
- The status of the central locking system button is also evaluated by the BDC. The BDC activates the central locking system, depending on the status.
- The BDC is responsible for the status recording and activation of the central locking system in the tailgate.

F48 General Vehicle Electronics

6. Locking and Security Functions

6.2.1. Special functions

Automatic locking (Personal Profile)

From a speed greater than 16 km/h the vehicle is automatically locked.



Different functions of the central locking system can be individually adjusted via the central information display.

Automatic unlocking in the event of a crash

As soon as the Body Domain Controller (BDC) receives a crash message from the Advanced Crash Safety Module (ACSM), the vehicle is unlocked.

After the crash message, the central locking button and the remote control receiver are blocked for the central locking system function. Both are only reactivated after a terminal change.

Selective unlocking

The vehicle can also be selectively unlocked in the case of corresponding encoding. Initially, only the driver's door is unlocked. The rest of the vehicle is unlocked upon a subsequent request for unlocking. Depending on the operating point and the national-market version, the fuel filler flap is already unlocked after the first or second request.

Convenient opening

By operating the remote control button "Unlock" for approximately 3 seconds the convenient opening can start. The windows and, if installed the panorama glass roof (SA 402), are opened in the process. The button on the remote key must be held down until the process is complete.

Convenient closing

By operating the remote control button "Lock" for approximately 3 seconds the convenient closing can start. The windows and, if installed the panorama glass roof (SA 402), are closed in the process. The button on the remote key must be held down until the process is complete.

If the vehicle has the optional equipment Comfort Access (SA 322), the windows and the panorama glass roof (SA 402) can be closed by pressing the grooved surface on the outer door handle.

F48 General Vehicle Electronics

6. Locking and Security Functions

6.2.2. System wiring diagram

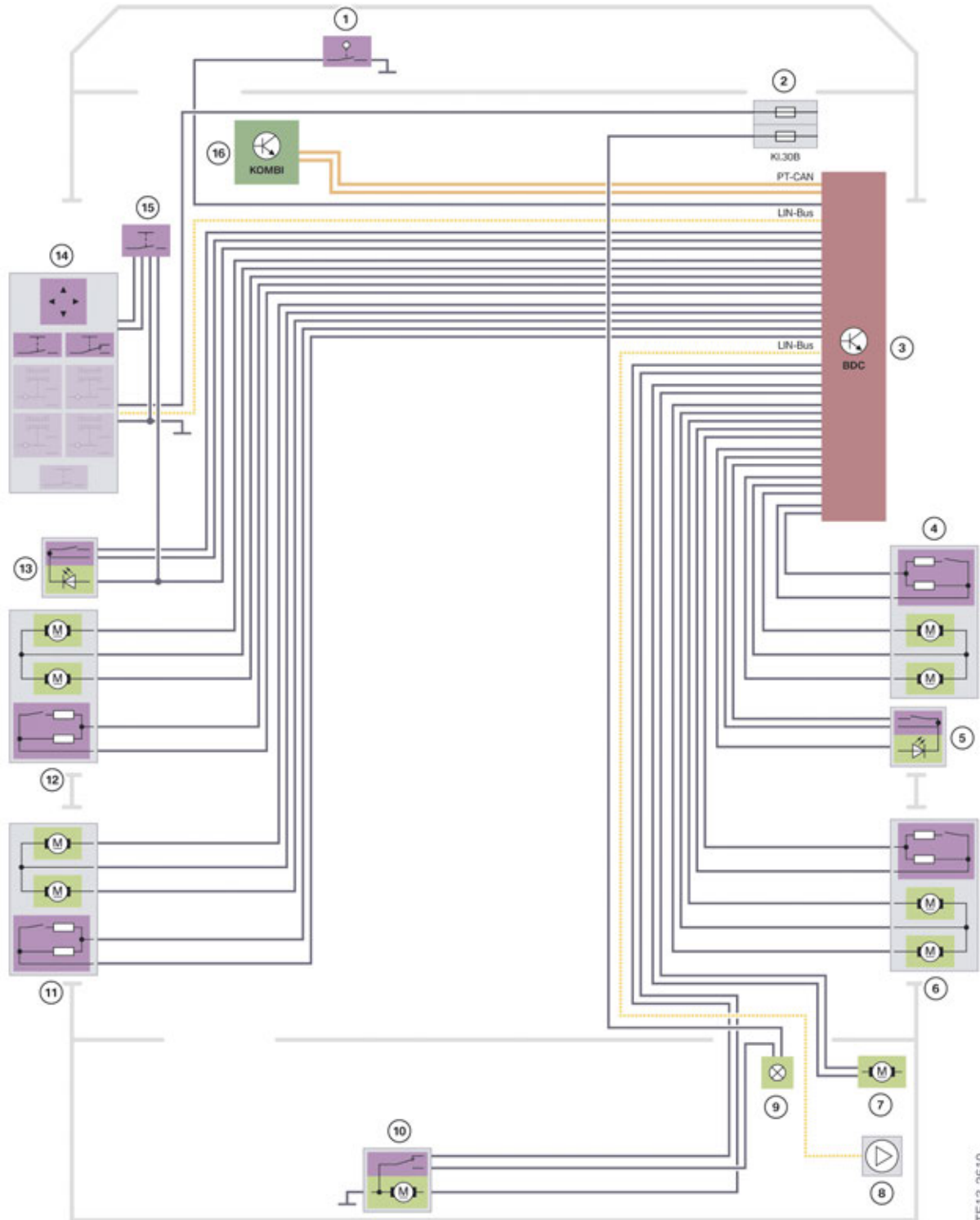

F48 system wiring diagram for central locking system

TE13-2610

F48 General Vehicle Electronics

6. Locking and Security Functions

Index	Explanation
1	Engine compartment lid contact switch
2	Fuses in the power distribution box in the passenger compartment
3	Body Domain Controller (BDC)
4	Door lock, passenger's side, front
5	Central locking button on passenger's side
6	Door lock, passenger's side, rear
7	Servo drive for fuel filler flap
8	Remote control receiver
9	Luggage compartment light
10	Tailgate lock
11	Door lock, driver's side, rear
12	Door lock, driver's side, front
13	Central locking button, driver's side
14	Switch block for driver's side
15	Button for tailgate activation
16	Instrument cluster (KOMBI)

F48 General Vehicle Electronics

6. Locking and Security Functions

The central locking button is designed as a rocker switch in the F48.

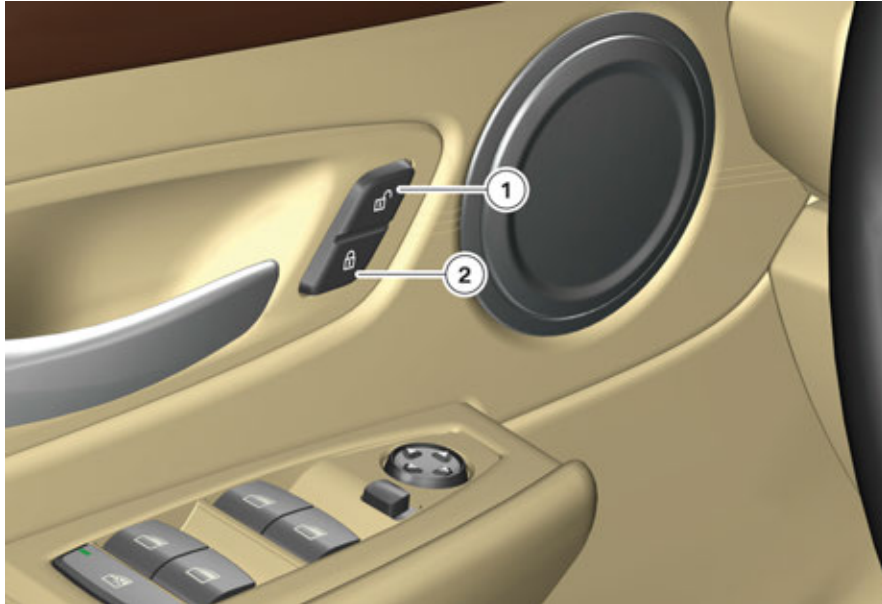

F48 central locking button

Index	Explanation
1	Unlock vehicle
2	Lock vehicle

6.3. Comfort Access

With the optional equipment Comfort Access (SA 322), the F48 obtains access to the vehicle without a key. The Comfort Access function is already known from other BMW models.

F48 General Vehicle Electronics

6. Locking and Security Functions

6.3.1. System wiring diagram

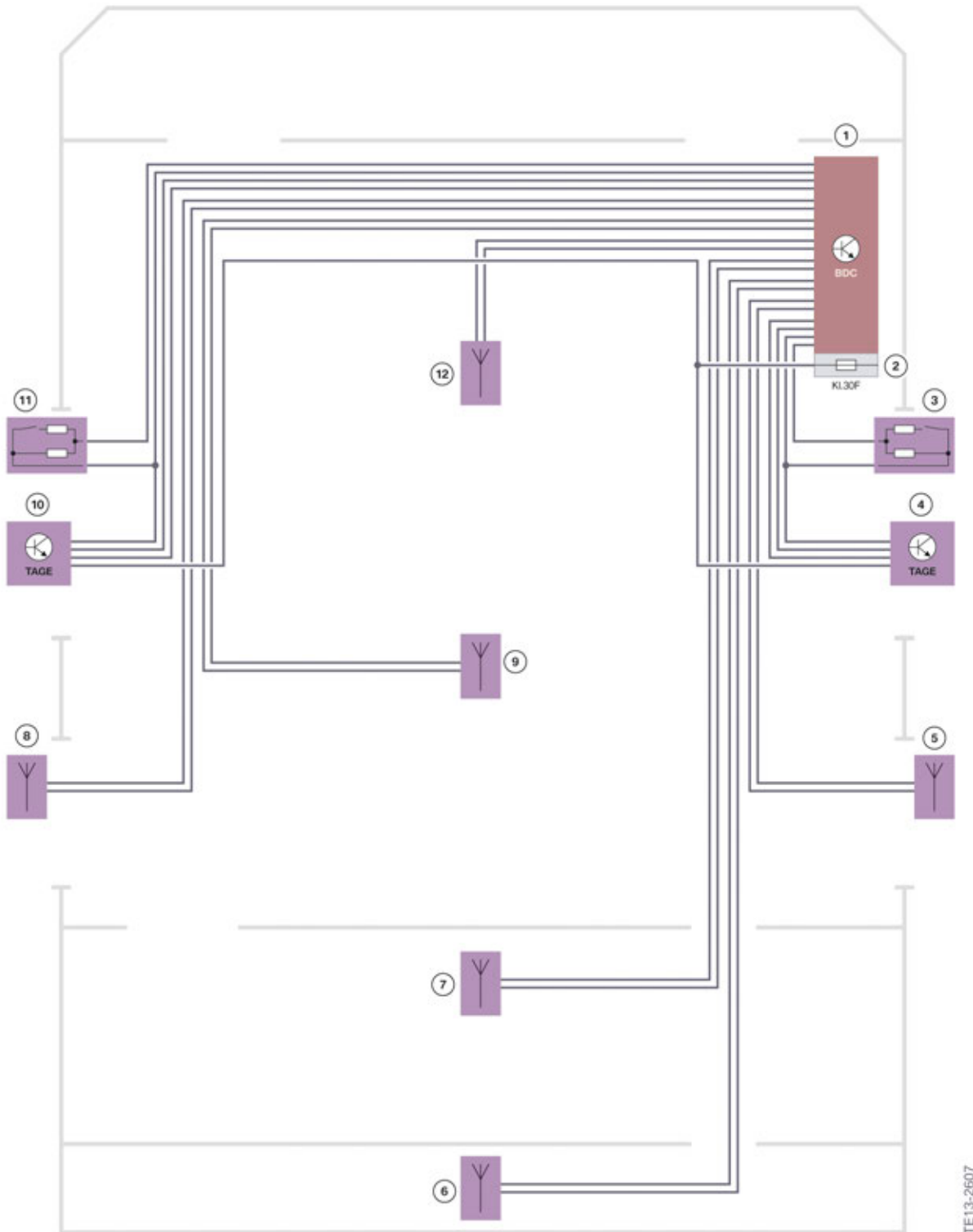

TE13-2607

F48 system wiring diagram for Comfort Access

F48 General Vehicle Electronics

6. Locking and Security Functions

Index	Explanation
1	Body Domain Controller (BDC)
2	Fuse in the Body Domain Controller
3	Door contact, passenger's side
4	Outside door handle electronics, passenger's side
5	Exterior antenna, passenger's side
6	Exterior antenna, rear bumper
7	Interior antenna, luggage compartment
8	Exterior antenna, driver's side
9	Interior antenna, rear
10	Outside door handle electronics, driver's side
11	Door contact, driver's side
12	Interior antenna (front)

F48 General Vehicle Electronics

6. Locking and Security Functions

6.3.2. System components

For the CA function, the Body Domain Controller activates the aerials for the exterior and passenger compartment.

The outside door handle electronics TAGE are also read in by the BDC.

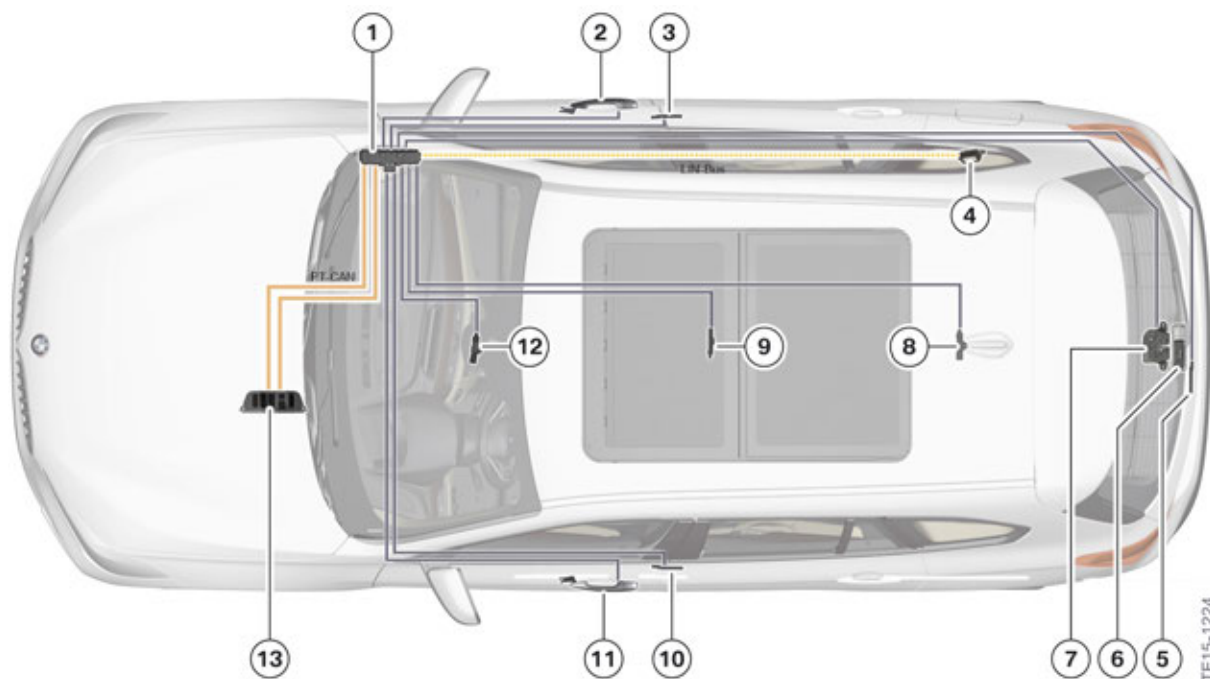

F48 installation location of the Comfort Access aerials

Index	Explanation
1	Body Domain Controller (BDC)
2	Outside door handle electronics, right
3	Antenna for outer area, right
4	Remote control receiver
5	Antenna for outer area in the rear bumper
6	Tailgate button
7	Tailgate lock
8	Interior antenna, luggage compartment
9	Interior antenna, rear
10	Antenna for outer area, left
11	Outside door handle electronics, left
12	Interior antenna (front)
13	Digital Motor Electronics (DME)

The function of Comfort Access is known from current BMW models.

F48 General Vehicle Electronics

6. Locking and Security Functions

6.4. Hands free tailgate opening

In combination with the optional equipment Comfort Access (SA 322) and automatic operation of tailgate (SA 316), the F48 has hands free tailgate opening.

F48 General Vehicle Electronics

6. Locking and Security Functions

6.4.1. System wiring diagram

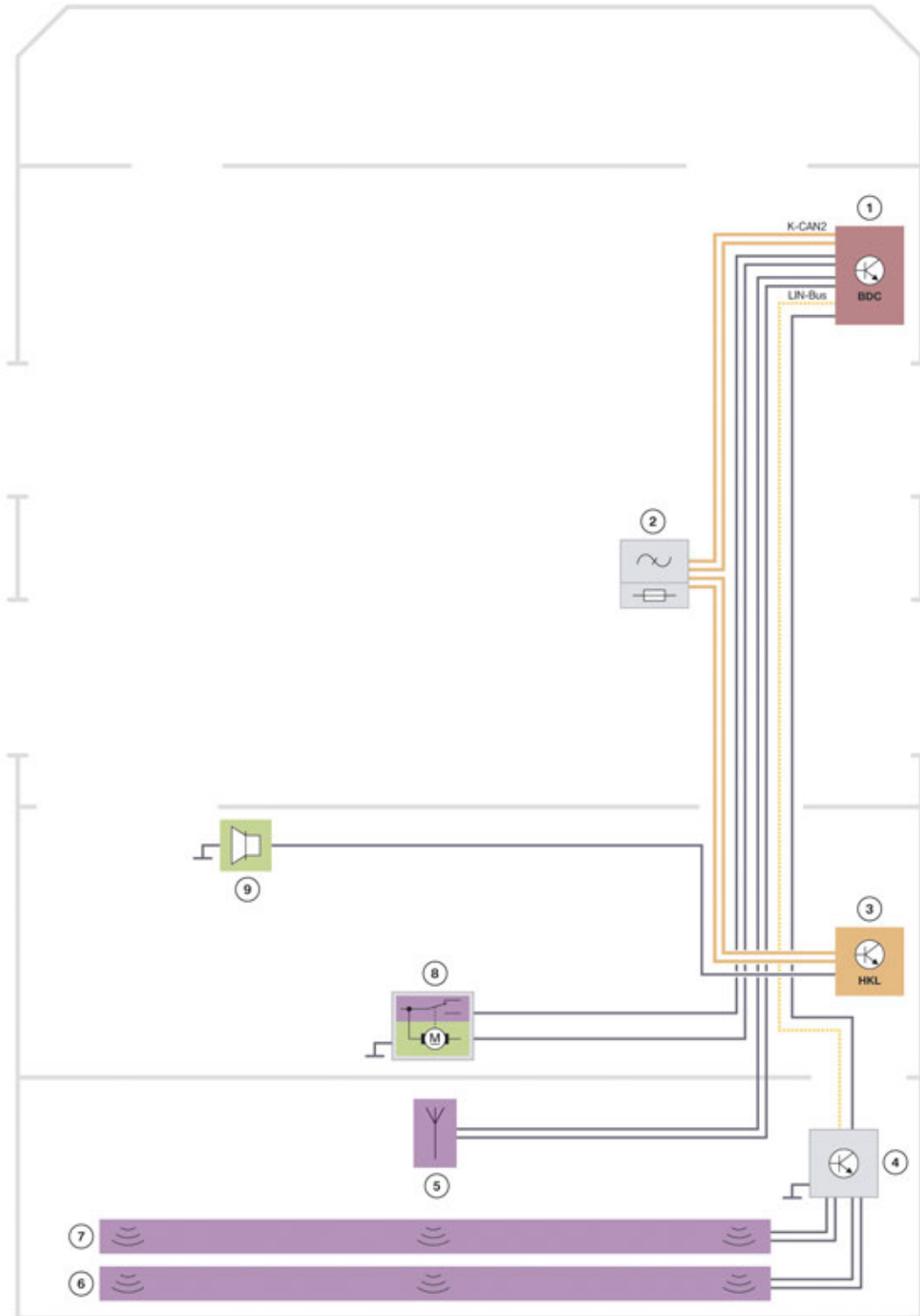

TE13-2615

F48 system wiring diagram for non-contact tailgate opening

F48 General Vehicle Electronics

6. Locking and Security Functions

Index	Explanation
1	Body Domain Controller (BDC)
2	K-CAN terminator
3	Automatic operation of tailgate (HKL)
4	Control electronics for non-contact tailgate opening
5	Exterior antenna, rear bumper
6	Sensor at top for non-contact tailgate opening
7	Sensor at bottom for non-contact tailgate opening
8	Tailgate lock switch
9	Acoustic warning device

6.4.2. Functional description of tailgate opening

The operation is effected by means of targeted foot movement to and from the bumper. Two sensors detect the movement contactlessly via capacitive measurement.

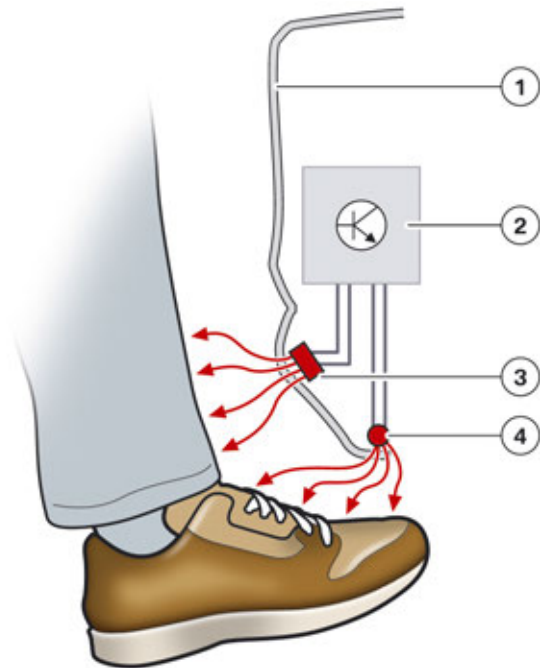

F48 non-contact tailgate opening by foot movement

Index	Explanation
1	Cross-section, rear bumper
2	Evaluation electronics for non-contact tailgate opening
3	Sensor at top for non-contact tailgate opening
4	Sensor at bottom for non-contact tailgate opening

F48 General Vehicle Electronics

6. Locking and Security Functions

The following components are involved in the function:

- Body Domain Controller
- Tailgate lock
- Evaluation electronics for non-contact tailgate opening
- Automatic operation of tailgate (HKL)
- Comfort Access antenna, bumper, rear
- Two capacitive sensors
- Acoustic warning device

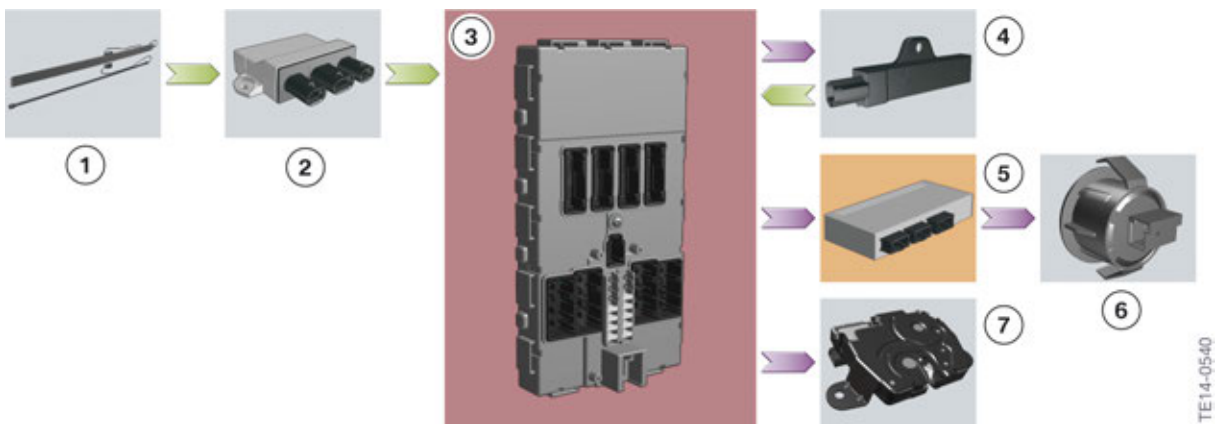

F48 inputs/outputs for non-contact tailgate opening

Index	Explanation
1	Capacitive sensors
2	Evaluation electronics for non-contact tailgate opening
3	Body Domain Controller (BDC)
4	Exterior antenna, rear bumper
5	Automatic operation of tailgate (HKL)
6	Acoustic warning device
7	Tailgate lock

F48 General Vehicle Electronics

6. Locking and Security Functions

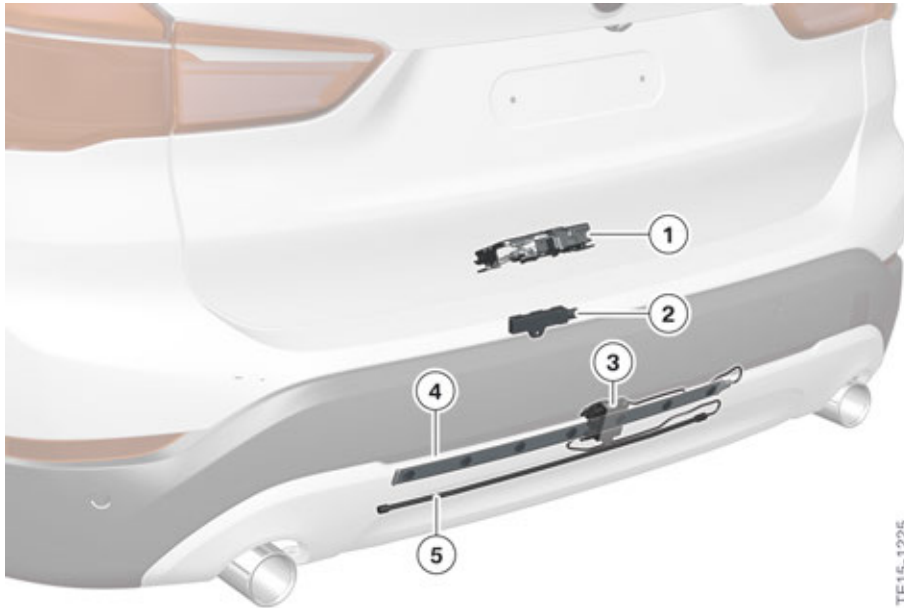

F48 sensors for non-contact tailgate opening

Index	Explanation
1	Tailgate lock
2	Comfort Access antenna, bumper, rear
3	Evaluation electronics for non-contact tailgate opening
4	Sensor at top for non-contact tailgate opening
5	Sensor at bottom for non-contact tailgate opening

The two sensors are connected to the evaluation electronics and constantly measure the capacity. A comparison of the time characteristic of the measured capacities permits the identification of a certain movement pattern.

A targeted foot movement to and from the bumper can be detected herefrom. The top sensor detects the shin, the bottom sensor the toes.

The detection range is between the rear lights.

The sensors are secured in the inside of the rear bumper.

The evaluation electronics evaluate the signals from the sensors and make this information available to the BDC via the local interconnect network bus. If there is a valid ID transmitter near the Comfort Access antenna in the rear bumper, the BDC initiates an opening of the tailgate.

The tailgate opens regardless if it was locked or unlocked.

The tailgate of the F48 can also be closed again using the same foot movement as for opening.

With the closing of the tailgate via the non-contact tailgate activation, a sound is output by an acoustic warning device, which is installed in the tailgate.

F48 General Vehicle Electronics

6. Locking and Security Functions

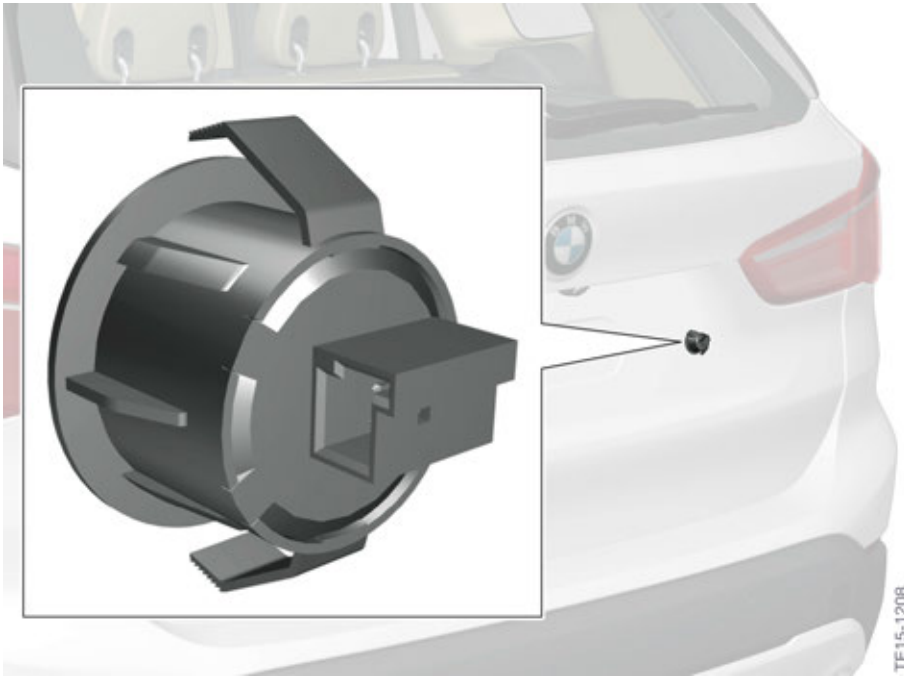

F48 acoustic warning device

F48 General Vehicle Electronics

7. Alarm System

7.1. System wiring diagram

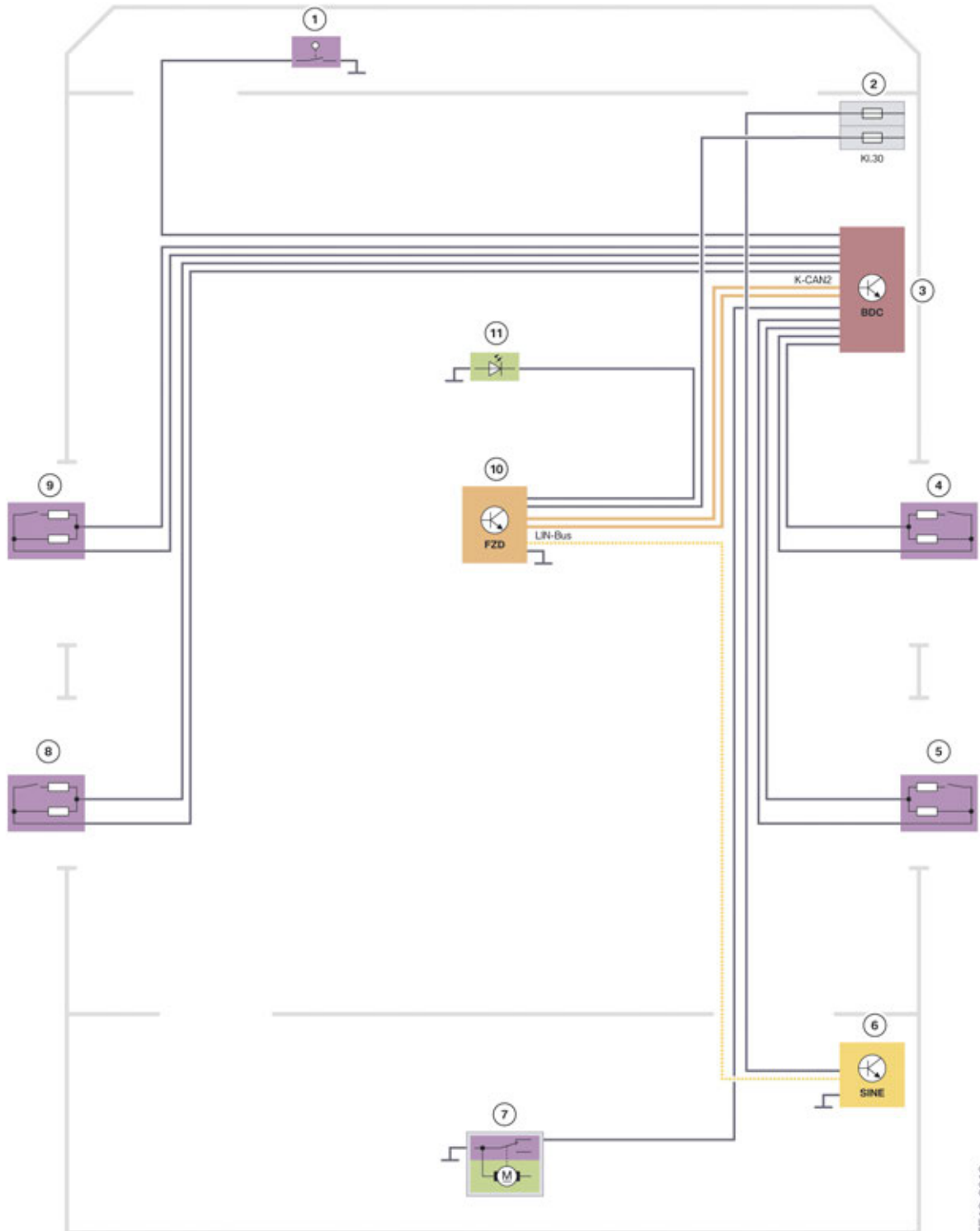

F48 system wiring diagram for alarm system

TE13-2612

F48 General Vehicle Electronics

7. Alarm System

Index	Explanation
1	Engine compartment lid contact switch
2	Fuses in the power distribution box in the passenger compartment
3	Body Domain Controller (BDC)
4	Door contact, passenger's side, front
5	Door contact on passenger's side, rear
6	Siren with tilt alarm sensor
7	Tailgate lock contact
8	Door contact, driver's side, rear
9	Door contact, driver's side, front
10	Roof function center (FZD)
11	LED in the interior mirror

The alarm system in the F48 is optional equipment (SA 302).

The alarm system in the F48 is equipped with an ultrasonic interior movement detector for monitoring the passenger compartment. The ultrasonic interior movement detector (USIS) is fully integrated in the roof function center (FZD).

The door contacts, engine compartment lid switch and the opening of the tailgate are monitored by the Body Domain Controller. As soon as a status changes, the ultrasonic interior movement detector receives this information via the K-CAN2. In the event of an activated alarm system a siren with tilt alarm sensor is activated by the control unit in the event of a break-in.

The SINE is connected to the roof function center via a local interconnect network bus.



By operating the central locking button on the remote key twice, the tilt sensor and the interior movement detector are deactivated up to the next unlocking process.

The status of the alarm system is displayed via the LED at the interior mirror.

F48 General Vehicle Electronics

8. Wash/Wipe System

8.1. Introduction

The following wipe/wash functions are possible in the F48:

- Intermittent wipes
- Continuous wipe in interval stage 1
- Continuous wipe in interval stage 2
- Flick wipes

Other equipment for the F48:

- Washer jet heating (standard equipment)
- Automatic mode via rain-light-solar-condensation sensor (SA 521)

8.2. Operation

The F48 has a newly designed wiper lever. The rear wiper is no longer activated by pressing the complete wiper lever, but using a rotary switch.



F48 wash/wipe switch

Index	Explanation
1	Windscreen wiper, wiper stages
2	Interval setting or for rain sensor (SA 521) sensibility setting
3	Rotary switch for rear window wiper function
4	Automatic button, for rain sensor (SA 521)

F48 General Vehicle Electronics

8. Wash/Wipe System

8.3. System wiring diagram

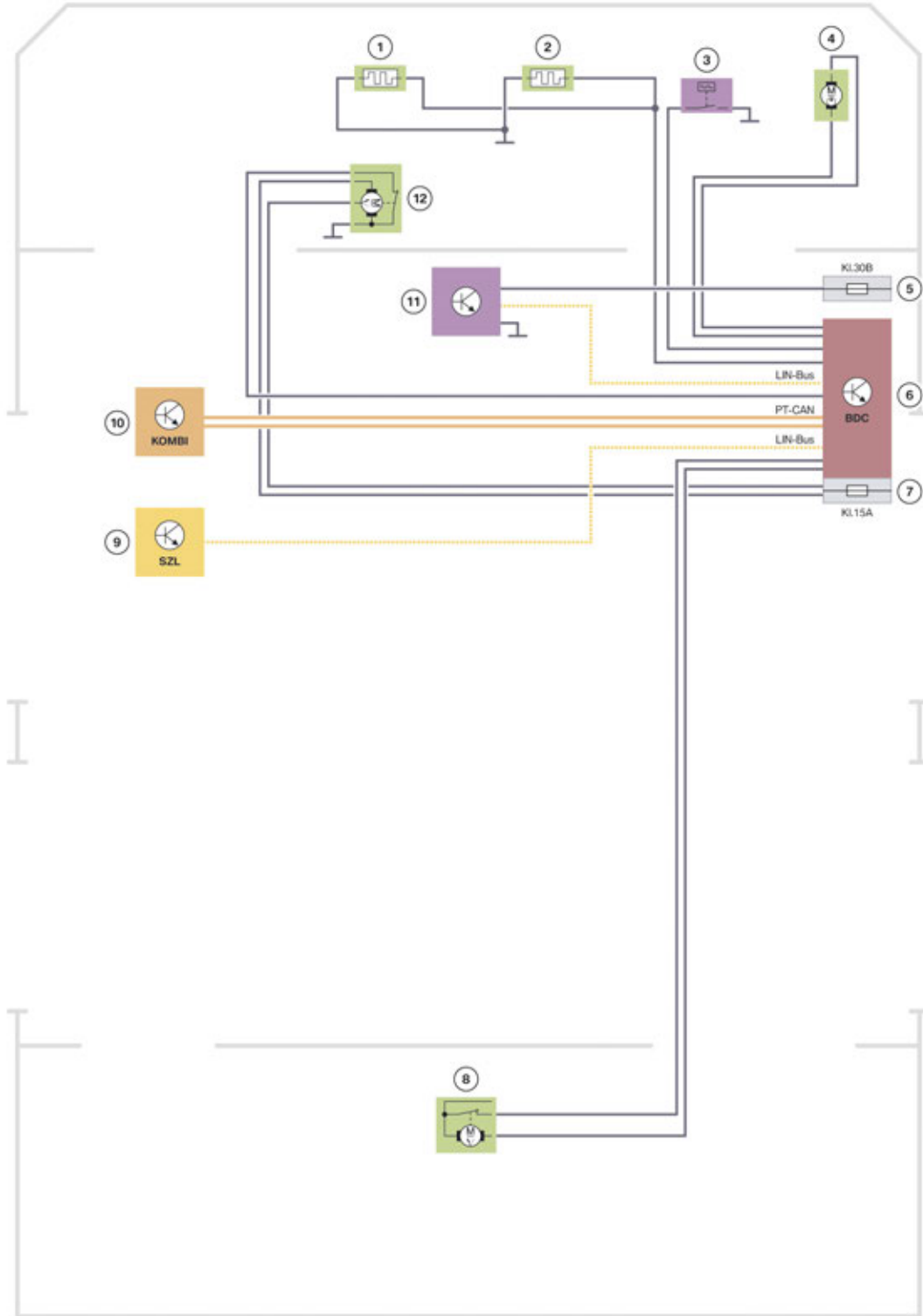

TE13-0900

F48 system wiring diagram for wash/wipe system

F48 General Vehicle Electronics

8. Wash/Wipe System

Index	Explanation
1	Heated washer jet, left (SA 313)
2	Heated washer jet, right (SA 313)
3	Washer fluid level switch
4	Electric motor, windscreen washer pump
5	Fuse in the power distribution box in the passenger compartment
6	Body Domain Controller (BDC)
7	Fuse in the power distribution box Body Domain Controller
8	Wiper motor, rear
9	Steering column switch cluster (SZL)
10	Instrument cluster (KOMBI)
11	Rain-light-solar-condensation sensor (RLSBS)
12	Wiper motor, front

F48 General Vehicle Electronics

9. Steering Wheel Heating

9.1. System wiring diagram

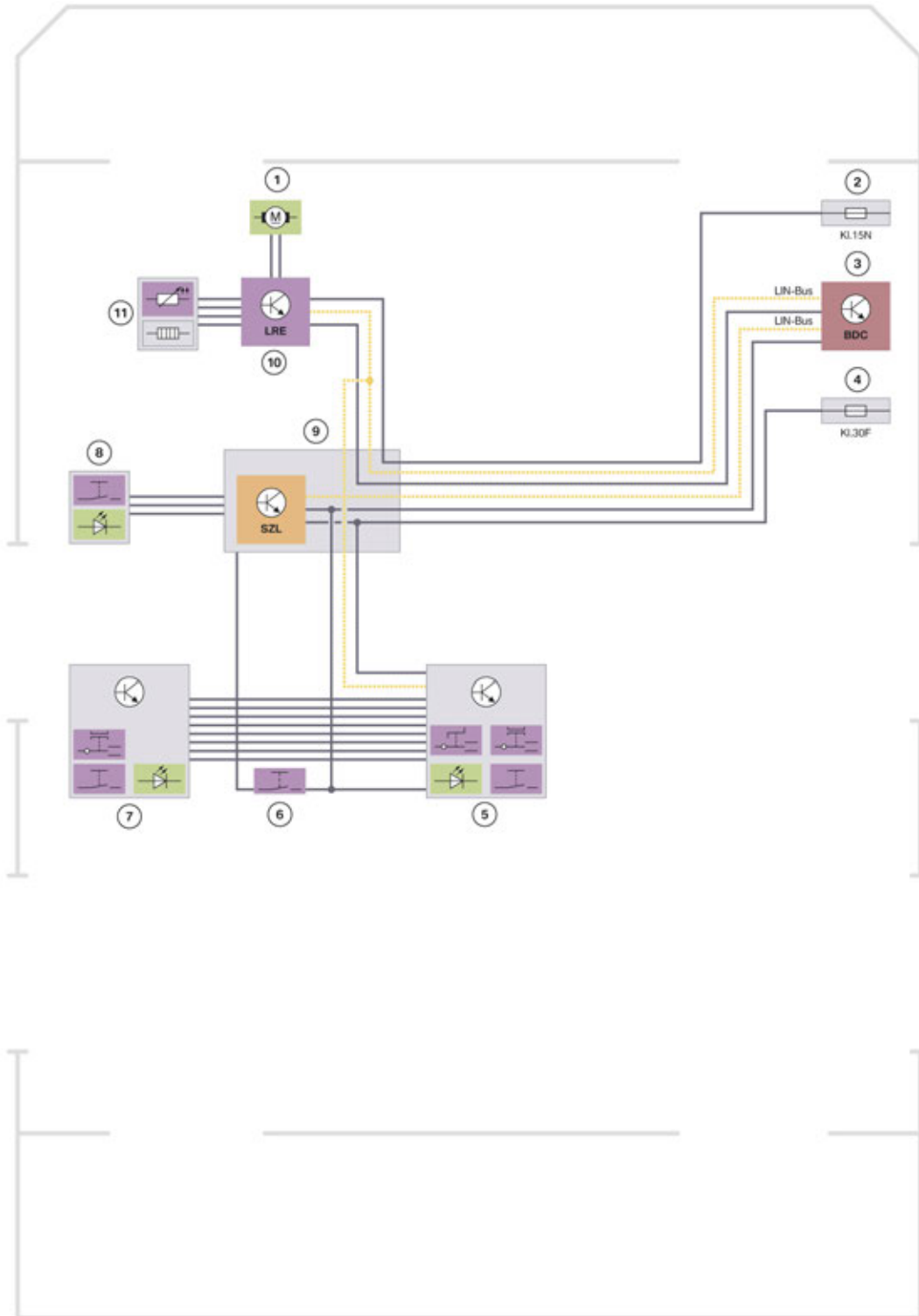

TE13-2663

F48 system wiring diagram for steering wheel heating

F48 General Vehicle Electronics

9. Steering Wheel Heating

Index	Explanation
1	Vibration actuator
2	Fuse in the power distribution box in the passenger compartment
3	Body Domain Controller (BDC)
4	Fuse in the Body Domain Controller
5	Multifunction steering wheel buttons, right
6	Horn switch
7	Multifunction steering wheel buttons, left
8	Button, steering wheel heating
9	Steering column switch cluster (SZL)
10	Steering wheel module
11	Heating element for the steering wheel heating

The F48 receives a steering wheel heating (SA 248) as optional equipment. The steering wheel heating is only available in conjunction with the leather sports steering wheel (SA 255).



Bayerische Motorenwerke Aktiengesellschaft
Qualifizierung und Training
Röntgenstraße 7
85716 Unterschleißheim, Germany