Table of Contents

E70 Head-up Display (HUD)

Subject	Page
Introduction	5
Head-up Display HUD.	5
Functions	8
Projection Distance	9
Switch-on Conditions	9
Switch-on Performance	10
Switch-off Conditions	10
Brightness Offset	10
Operating-hours Counter	11
Priority Management	11
Display Area	12
Color Selection	12
System Components	13
Cover Glass	14
Mirrors	15
LED Power Supply	15
LED Array	15
PCB	16
Housing	16
Windshield	16
Incorrect Windshield Fitted	18
Light Module	19
Rain/light Sensor	19
Junction Box	19
Eye Box	19
Image Sources	20
CHAMP/CCC	20
Instrument Cluster	21
Check Control Messages	21
Controls	22
Light Switch Center	22
Instrument-lighting Dimming	22
Controller	22

Subject	Page
Service Information	23
Adjusting the Brightness	23
Adjusting the Height of the Horizon	24
Vertical Rotation of the HUD	24
Test Functions	25
Carry Out a System Test	26
Replacing the HUD	26
Image Defects	26
Fading	27
Correcting Distortion (warping)	27
Diagnosis	28
Sleep Mode	28

**BLANK
PAGE**

Head-up Display

Model: E70

Production: From Start of Production

OBJECTIVES

After completion of this module you will be able to:

- Describe the operation of the Head-up Display (HUD) System on the E70
- Identify the components of the HUD on the E70

Introduction

Head-up Display (HUD)

The very name "Head-up" describes the principle benefit of this system. The Head-up display (HUD) projects important information such as cruise control data or instructions from the navigation arrow are reflected onto the windshield glass and are thus permanently in the driver's field of vision. The driver of a BMW can have important data and graphics displayed directly in front of him, just like a pilot of a jet fighter.

The Head-up display contains various functions aimed at enhancing road safety and driving comfort. This include displays:

- Cruise control DCC Data
- Navigation system information
- Check Control messages
- Vehicle speed.

Having the displays in the driver's direct field of view increases safety, as the eyes are always on the traffic.



Heads-up Display System Schematic Circuit Diagram

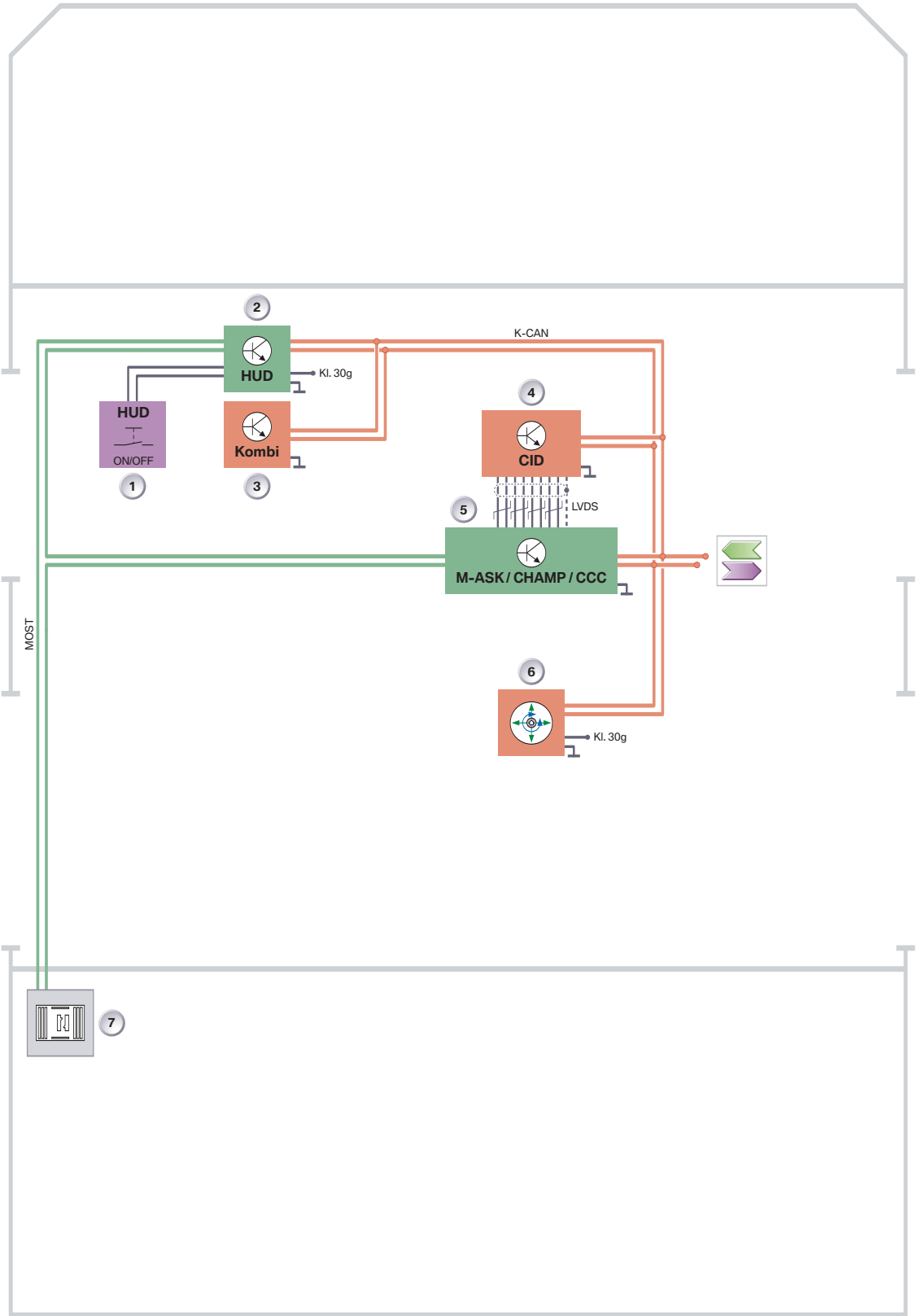

Heads-up Display System Schematic Circuit Diagram Legend

Index	Explanation	Index	Explanation
1	Light switch center	7	MOST station
2	Head-up display HUD	K-CAN	Body CAN
3	Instrument cluster	MOST-Bus	Media Oriented System Transport bus
4	Central Information Display CID	LVDS	Low Voltage Differential Signalling
5	Multi-audio system controller Central Head unit And Multimedia Platform CHAMP Car Communication Computer CCC	KL 30g	Terminal 30g
6	Controller		

K-CAN and MOST Signals to the HUD Control Unit

In/out	Information	Source/sink	Function
In	Road speed	Instrument cluster	Display in the HUD
In	Check control message	Instrument cluster	Display in the HUD
In	Dimming/brightness	Rain and driving light sensor(RLS) via roof function center (FZD)	Brightness adjustment
In	Height adjustment	CHAMP, CCC	Height adjustment
In	Brightness offset	CHAMP, CCC	Brightness adjustment
In	DCC	EHB3	Display in the HUD
In	Function selection	CHAMP, CCC	What is displayed in the HUD
In	On/Off switch	Light switch center (LZ)	Switching the HUD On/Off
In	Navigation	CHAMP, CCC	Display in the HUD

Functions

The HUD can be compared to a projection device. A light source is required to project the HUD information. The LED array acts as this light source. The image content is created by the TFT projection display. The TFT projection display can be compared to a filter which admits or blocks light.

An optical imaging element determines the shape, distance and size of the HUD images. The image appears to float freely over the road, the windshield acts as a deflecting mirror.

Principle of the Head-up Display

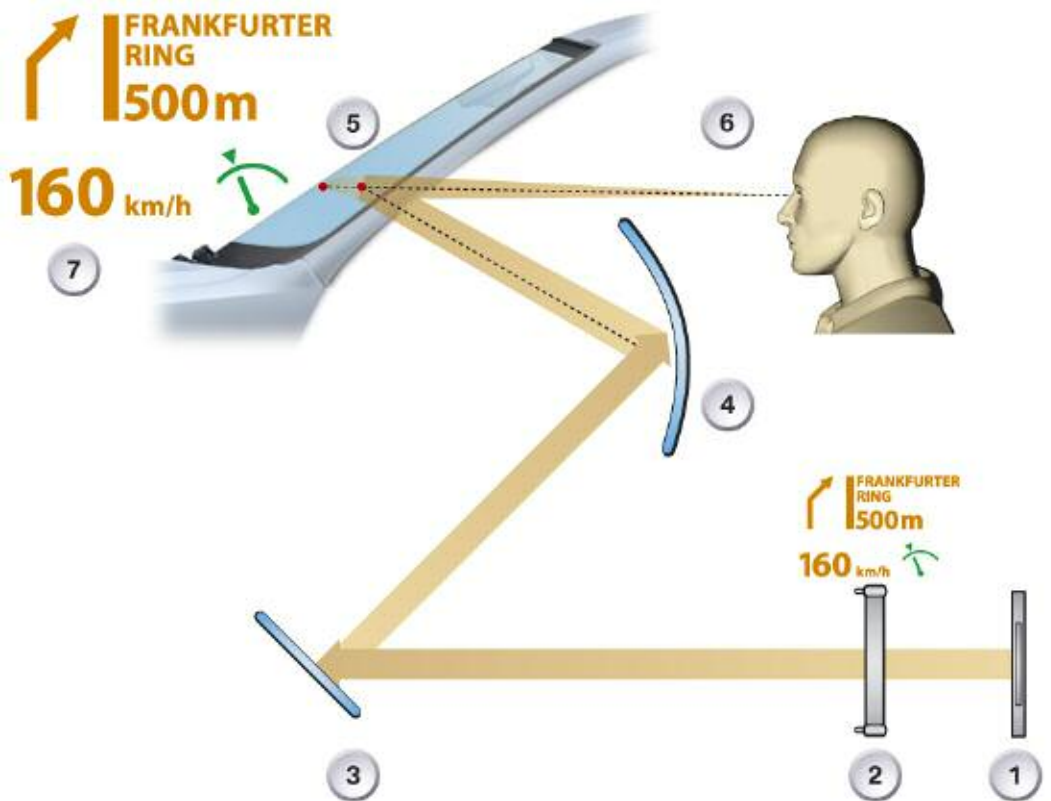

Index	Explanation	Index	Explanation
1	LED array	5	Windshield
2	TFT projection display	6	Observer's point of vision
3	Plane mirror	7	Projected image
4	Curved mirror		

Projection Distance

The projected HUD image content appears at a distance of approximately 2.2 m from the observer's eye.

Projection Distance

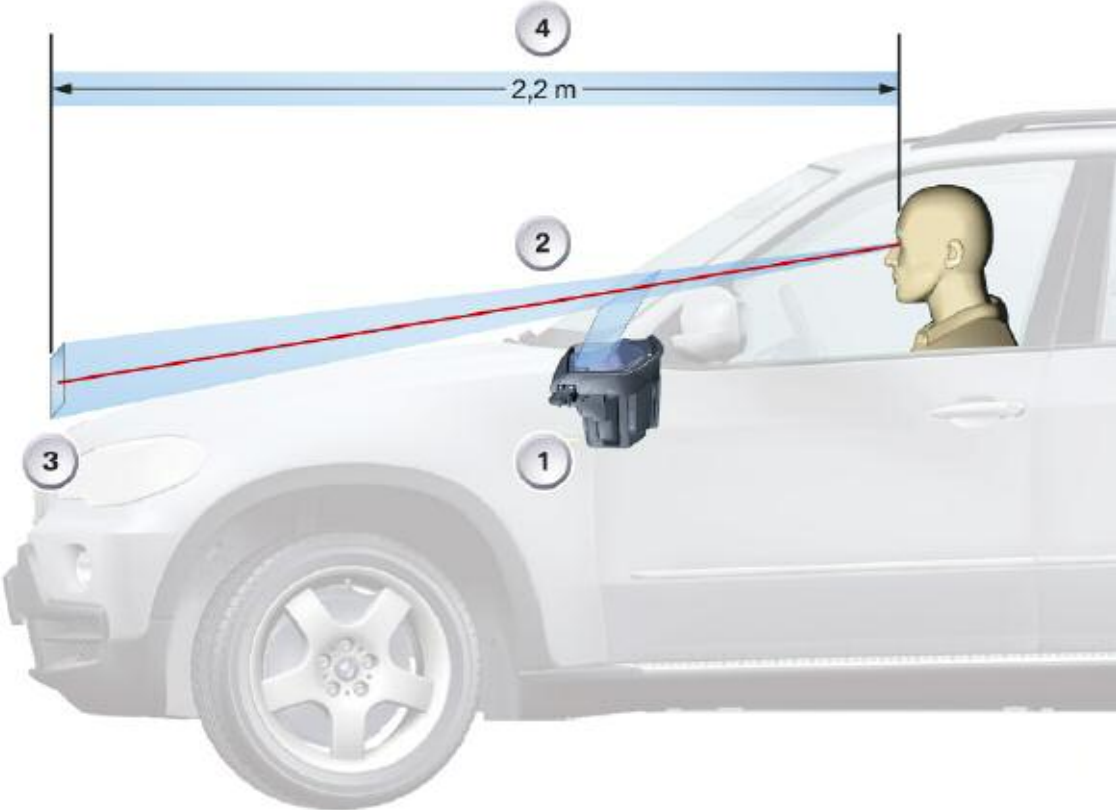

Index	Explanation	Index	Explanation
1	Head-up display	3	Projected image
2	Windshield	4	Projection distance

Switch-on Conditions

The following conditions are required to release the light:

- Terminal 15 ON
- Switch (HUD) in the light switch cluster pressed.

Switch-on Performance

The HUD receives the terminal 30 ON status via the K-CAN. The HUD is partially ready for operation from terminal R ON. This means that:

- The HUD can communicate with the other electrical-system users via the K-CAN and MOST
- The TFT projection display is initialized and blanked
- The LEDs are off.

The HUD receives the terminal 15 ON status via the K-CAN. The HUD is ready for operation from terminal 15 ON. This permits the following actions:

- Activation of the back lighting via the button in the light switch cluster
- HUD height adjustment
- Adjustment of HUD brightness
- Display of information via the HUD.

When the vehicle is started, the vehicle is set to terminal 50 status. In terminal 50, i.e. Lights Off, the HUD goes into a hold status. This hold status is maintained until shortly after the end of the terminal 50 status.

Switch-off Conditions

The HUD is switched off under the following conditions:

- Button in the light switch clutter
- Terminal R OFF
- Terminal 30g OFF.



Brightness Offset

Brightness offset is a Personal Profile function PIA. Brightness offset allows the customer to apply his own individual HUD base brightness setting and to store it. Each time the HUD is switched on, this setting is used as the brightness offset for the HUD.

The brightness setting is adjusted with the controller via the CID. Any value between -10 and +10 can be set. The mid-position value is 0. The value is transferred via the K-CAN to the HUD.



The brightness setting is automatically corrected in order to compensate for different light conditions. Compensation is based on signals from the rain and light sensor. The automatic brightness setting is configured in such a way that no HUD brightness jumps occur.

The differing light conditions depend, for instance, on:

- Environmental conditions, such as day, night, sunshine, clouds, rain, fog, snow etc.
- Structural conditions, such as tunnel, underground car park etc.
- The driver can adjust the brightness of the instrument lighting with the knurled wheel.
- From terminal 58g lights on, the HUD brightness is determined by the brightness setting of the instrument lighting.

The brightness is dependent on the following conditions:

- Dimmer-wheel setting
- Brightness offset
- RLS.

The precise setting of the brightness is described in this Product Information in the "Service advice" section.

Operating-hours Counter

The HUD incorporates operating-hours counters for both the HUD and the LED array. When the HUD is replaced, the operating hours counter must be initialized at 0.

Priority Management

The HUD receives a whole range of information which is to be displayed. Since some information is more important than other information, the HUD is subject to priority management. These priorities are:

1. Diagnosis
2. Check control messages
3. Test functions
4. Navigation.

Display Area

The HUD size is approximately 200 mm x 100 mm with a display resolution of 480 x 240 pixels. The HUD is separated into 2 display areas. The individual fields are "optically" separated in the image so that they can be identified more easily.

The upper area shows navigation information and CC messages in the form of symbol, bar display and text.

The lower area shows speed-related displays in the form of unit, current speed and cruise control.



Index	Explanation
1	Navigation/CC display area
2	Road speed/Cruise control display area

Color Selection

Symbols (such as warning symbols) are specified by the individual control units. This color specification is adopted for the display in the HUD. 2D symbols are used for optimum visibility and readability.

The colors are:

- Orange as the standard color
- Red or yellow for warning messages
- Green for the set speed
- The HUD background is transparent.

System Components

The separate components of the head-up display are the cover glass, mirrors, LED power supply, LED array, TFT projection display, PCB and casing. The head-up display can only be replaced as a complete unit. It is not possible to replace components or separate parts.

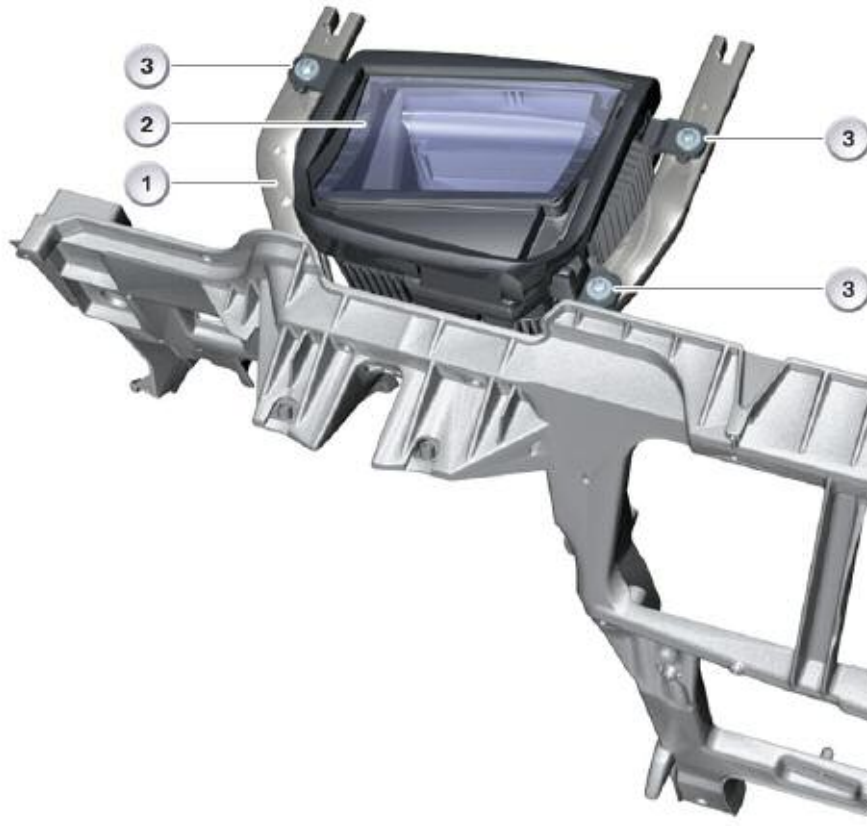

Index	Explanation	Index	Explanation
1	Carrier bracket	3	Hexagon bolt
2	Head-up display HUD		

Note: The head-up display is fitted above the steering column, immediately behind the instrument cluster. It is fastened to the bulkhead structure with three hexagon bolts.

The head-up display comprises the following components:

- Cover glass
- Mirrors
- LED power supply
- LED array
- TFT projection display
- PCB
- Housing.

The following components are required in addition to the components listed above:

- Windshield
- Light module
- Rain/light sensor
- Roof function center and junction box
- HUD trim.

The following elements are needed to operate the HUD:

- On/Off button in the light switch cluster
- Light switch in the light switch cluster
- Instrument-lighting dimmer and
- controller.

Cover Glass

The cover glass is made from scratch resistant, coated polycarbonate (PC) and closes off the top of the HUD. The cover glass protects the interior of the HUD against dust and objects accidentally placed on it.

The glass and the HUD trim are curved so that any incident light is not reflected back to the driver.

Furthermore, projection of the information in the display onto the windshield is guaranteed without hindrance from stray light effects, for instance.



Mirrors

Two mirrors are fitted in the head-up display. They reflect the information in the display onto the windshield.

The convex mirror (1) responsible for compensating the image on the windshield and for the size and distance of the image.

The flat mirror (2) is a deflecting mirror to keep the beam in the space provided. The convex mirror is made of plastic while the flat mirror is made of glass.



Index	Explanation
1	Curved mirror
2	Plane mirror

LED Power Supply

The power supply is a switched-mode power supply. It supplies the LED array with a voltage of 30 V which is transformed from the vehicle's electrical system voltage.



LED Array

The LED array is an arrangement of LEDs in one plane and acts as the back lighting for the TFT projection display. The LED array generates the light required for the HUD brightness.

White LEDs are fitted in the LED array. Depending on activation by the PCB, the LEDs generate the brightness of the HUD content.

At temperatures $< -30\text{ C}$, the display is heated by switching on the display heating.



PCB

The following components among others are incorporated on the PCB:

- K-CAN interface
- MOST interface
- Processor (CPU)
- Graphics controller
- EEPROM memory
- Power supply.

The image information is transferred to the master board via the K-CAN and MOST. The electronic circuit for image generation evaluates the incoming image information. The processed image information is then forwarded to the display.



Housing

The casing is made from plastic and comprises a lower section and the cover. The cooling (aluminum fins) and the electrical power supply are fastened to the lower section. The cover glass is integrated into the cover.



Windshield

The windshield is a "special" windshield and is an integral component vital to projecting the displays. The outer and inner glass panes are bonded to a plastic film, just like in the standard windshield. Unlike in the standard windshield, this plastic film is not parallel but is tapered over the entire area of the windshield.

The taper prevents the HUD from displaying images twice. The taper tip points downward and starts at a distance of about 10 cm to the bottom edge of the windshield.

The end of the taper is located at about 2/3 windshield height. In the top third of the windshield, the plastic film runs parallel to the outer and inner glass panes. The thickness of the taper tip is 0.8 mm. The thickness of the end of the taper is 1 mm. The total thickness of the bottom edge of the windshield is 4.5 mm.

The total thickness of the bottom edge of the windshield is 4.5 mm. The total thickness of the top edge of the windshield is 4.7 mm.

Windshield

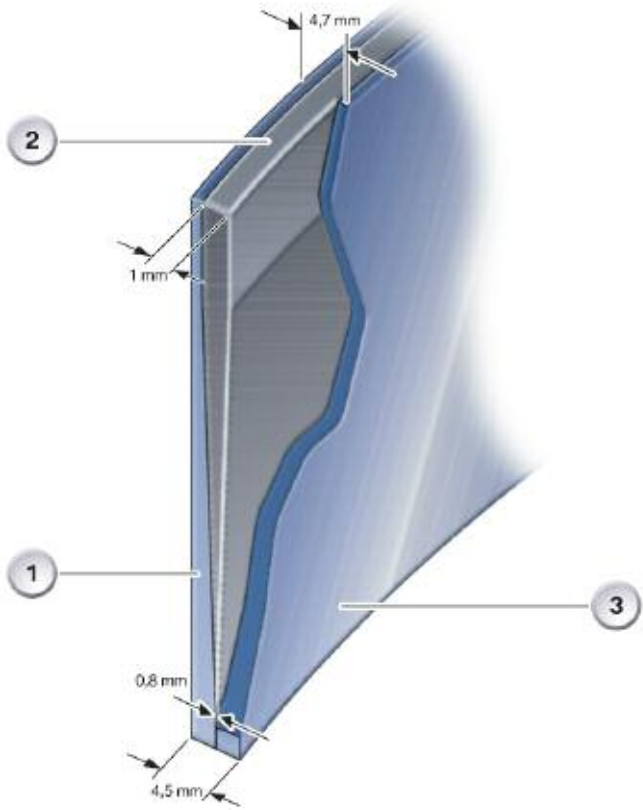

Index	Explanation	Index	Explanation
1	Outer glass pane	3	Inner glass pane
2	Plastic film	4	Unit of measurement in mm

Incorrect Windshield Fitted

The HUD image is always reflected on the inner surface and outer surface of the windshield.

Because of the angle of tilt of the glass in a standard windshield, the two reflected images are offset against one another. These two images are overlaid by the angle of the taper in the HUD screen, so that the driver only sees "one" image.

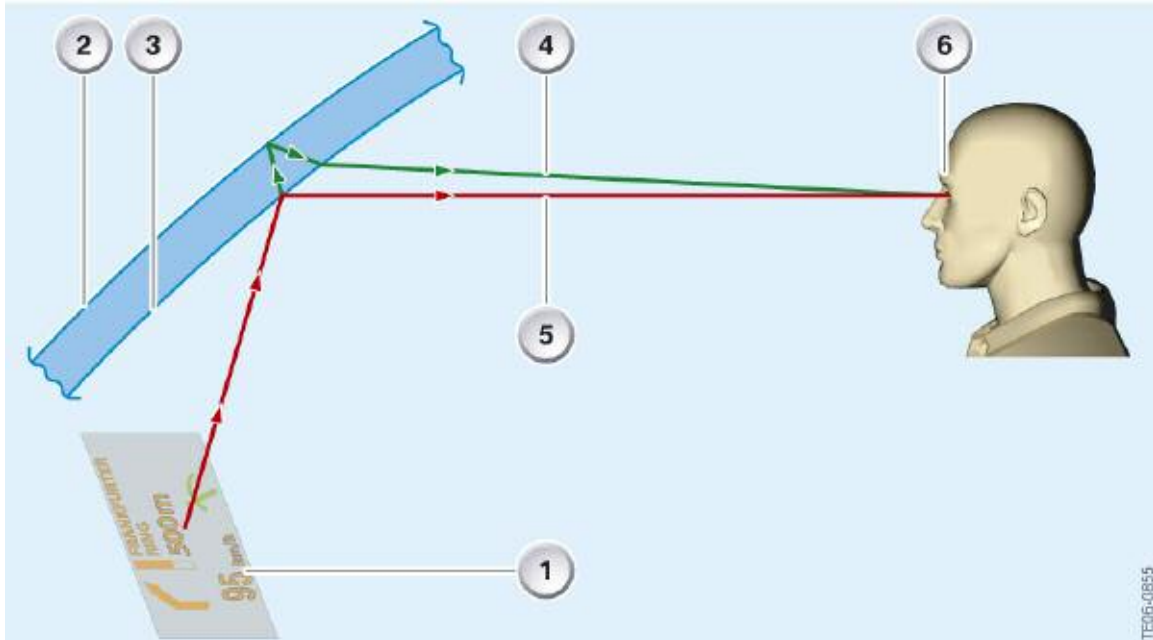

Index	Explanation	Index	Explanation
1	Display	4	Reflection on the outer surface of the windshield
2	Outer surface of the windshield	5	Reflection on the inner surface of the windshield
3	Inner surface of the windshield	6	Driver's eye

The illustration below shows the result when a standard windshield is fitted.



Light Module

The light module LM makes the terminal 58g signal available via the K-CAN.

Rain/light Sensor

The rain and light sensor provides the brightness signal over the LIN bus to the roof junction center FZD and then to the K-CAN.

Junction Box

The Junction Box JB has the gateway function.

Eye Box

The Eye box is the space in which the driver can move without his view of the image in the HUD being impaired.

The freedom of movement within the Eye box is roughly:

- 70 mm vertically plus ± 30 mm range of adjustment
- 130 mm horizontally
- The HUD image is not clearly visible outside the Eye box limits

Eye box, Shift to the Left or Right



Index	Point of vision	HUD image
1	Within the Eye box	Optimum illumination of the image
2	Offset to the left	Image cut off on the left
3	Offset to the right	Image cut off on the right

Eye box, Shift Upwards/downward

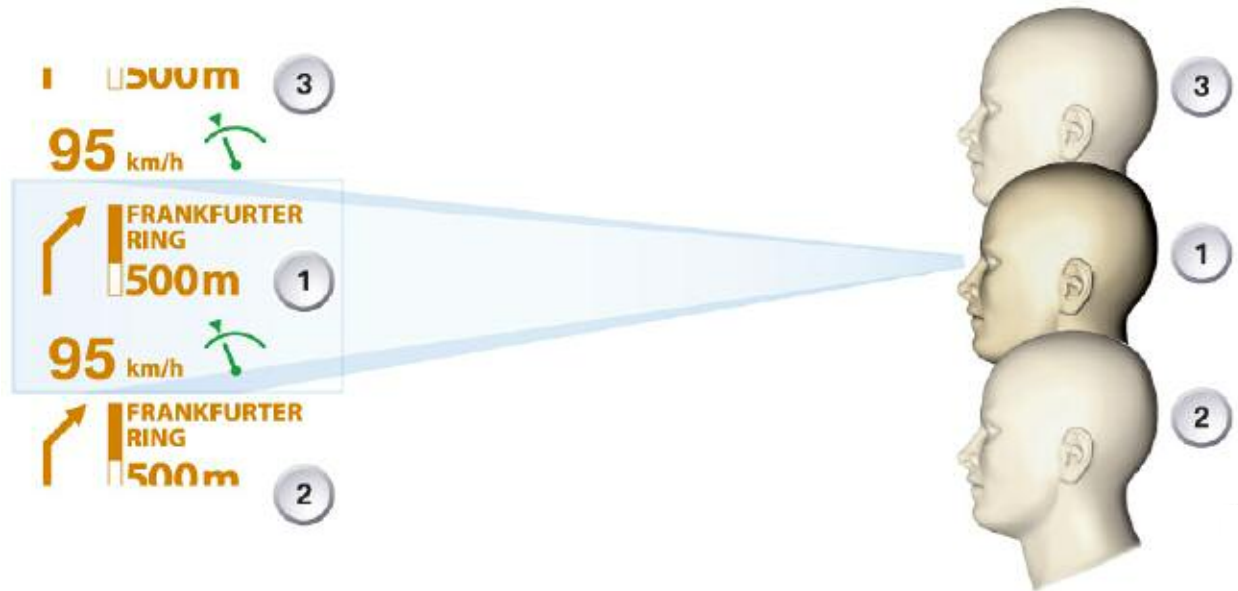

Index	Point of vision	HUD image
1	Within the Eye box	Optimum illumination of the image
2	Offset downward	Image cut off at the bottom
3	Offset upwards	Image cut off at the top

Image Sources

The following control units provide content for display in the HUD:

- Central Head unit And Multimedia Platform CHAMP/Car Communication Computer (CCC)
- Instrument cluster (KOMBI)
- Dynamic Stability Control (DSC)

CHAMP/CCC

The CHAMP/CCC provides the following signal content via the MOST for the navigation of the vehicle:

- Next road/street
- Guidance arrows
- Distance to next intersection/turn-off
- Bar graph, also called the bar display

The navigation signals are output on an event driven basis. The display in the HUD goes out if no more navigation signals are output.

As soon as navigation signals are present again, they are displayed again in the HUD with a brief delay.

Instrument Cluster

The instrument cluster makes the following signal information available via the K-CAN.

- Road speed
- Check Control messages
- Language/unit.

The road-speed signal is output by the instrument cluster.

The display in the HUD goes out if the display signal is no longer output for a specified period.

" --- " is displayed in the HUD instead of the speed reading. The lack of the road-speed signal is entered in the HUD fault memory.

As soon as the road-speed signal is present again, it is displayed again in the HUD with a brief delay.

A distinction is made between acceleration/ braking and coasting phases in order to filter the speed reading.

When the car is in the coasting phase, 3 successive values are averaged and then the speed is updated.

■ Check Control Messages

All CC messages are also displayed in the HUD. The instrument cluster has the master function for the messages. The symbol together with the associated text is stored in the HUD. CC messages are displayed as a matter of priority ahead of other displays such as for example, navigation instructions.

Note: A CC message is shown for 23 seconds. If several CC messages are to be displayed simultaneously, each CC message is shown for 3 seconds.

Controls

The following controls are used in the operation of the HUD:

- On/Off button in the light switch cluster
- Dimmer wheel in the light switch cluster
- Controller.

Light Switch Center

The HUD On/Off button is located in the light switch cluster. The button is resistance-coded and routed directly to the HUD. The HUD can identify the button signals or a button fault using the resistance coding.



Instrument-lighting Dimming

The dimmer setting is also used for the HUD with active headlights. The dimmer signal is emitted by the light module.



Controller

The HUD brightness and height settings are adjusted with the Controller via the CID. Brightness setting is also termed brightness offset.

Functions such as navigation can also be set with the Controller in the Function selection menu. Therefore these settings have an indirect effect on the HUD display.

Service Information

The following information for the technician is described in this section:

- Adjusting the brightness
- Adjusting the height of the horizon on the HUD
- Vertical rotation of the image
- Test functions
- Replacing the HUD
- HUD
- Diagnostics.

Adjusting the Brightness

The brightness of the HUD can be individually adjusted. The CID is the display instrument and the controller the control element for brightness adjustment.

The brightness is adjusted as follows:

- Call up the main menu by pressing the menu button
- Press the Controller and select the "Settings" menu item
- Turn the Controller until "Displays/Screen" is highlighted in the menu bar and then confirm by pressing the Controller; the upper menu bar is activated
- Turn the Controller until "Head-up display brightness" is highlighted in the upper bar and then confirm
- Set the desired brightness by turning the Controller and confirm by pressing.

Adjusting the Brightness



Adjusting the Height of the Horizon

In the E70, the driver has the ability to adjust the location of the image and the Eye box to his needs using the iDrive controller.

The Eye box can be shifted up to a maximum of ± 30 mm upwards or downward. The height setting is adjusted as follows:

Note: The height can only be adjusted when the HUD is active.

- Call up the main menu by pressing the menu button
- Press the Controller and select the "Settings" menu item
- Turn the Controller until "Displays/Screen" is highlighted in the menu bar and then confirm by pressing the Controller; the upper menu bar is activated



- Turn the Controller until "Position" is highlighted in the upper bar and then confirm
- Set the desired height by turning the Controller and confirm by pressing.

The height adjustment is in the scope of the PIA. The setting is stored in the EEPROM for each key. If a radio remote control key status message is received with terminal 30 on, the mirror moves to the position set for the current key.

The mirror remains in this position until the HUD is switched on. If the HUD is switched off by a press on the On/Off button, the mirror travels to the lower and position to protect the display.

Vertical Rotation of the HUD

The HUD is supplied as standard with a defined basic setting. The HUD image can be rotated in the horizontal by a service technician using vertical rotation, after a change of windshield, for instance.

Note: The display can be adjusted by a motor in steps of 0.25° from -3° to $+3^\circ$. Detailed information may be found in the BMW diagnostic system.

Test Functions

Calling/quitting test functions Certain test functions may be called as follows directly from the HUD, without using a BMW diagnostic system:

- Press and hold the button in the light switch cluster for about 15 seconds until the first test function is displayed
- Call up further test functions by pressing the button again
- To quit this function, press and hold the button in the light switch cluster for more than 5 seconds.

All the test functions are listed in the following table, just as for the instrument cluster test.

Test Function	Explanation
1	Identification -The ident data such as the BMW part number or the hardware version number is displayed. The identification and the system test can be called when the HUD is in the "locked condition". All other functions require that the HUD has been "unlocked".
2	System test -The HUD test cards are shown and then switched off.
3	H. Adjust
4	Rotation - Rotation right and Rotation left are selected by pressing a button.
5	Dimming
6	Equipment
7	PIA -The CKM system has been replaced by the PIA system on the X5 (E70). PIA is a development of CKM with extended functions such as porting of keys.
8	Sensor
9	DTC IS
10	DTC
11	I/O
12	Test bitmap
13	A/D
14	PWM
15	Lock Unlocking; Unlock by entering the 5 digit checksum for the vehicle identification number.
16	Reset
17	Exit

Carry Out a System Test

The system test runs through an automatic routine during which the optical quality of the display may be examined.

The system test comprises the following sequence:

- Backlight increased to the maximum possible value of pulse width modulation (PWM)
- Run-through of the display of test images The test images can be used to evaluate optical defects.
- Deactivation of the LEDs.



Menu items 3 to 14 are not initially available and must first be unlocked in menu item 15 as follows:

- Select menu item 15 with the On/Off button in the light switch cluster
- Enter the checksum for the vehicle identification number using the On/Off button
- Press the On/Off button to quit unlocking.

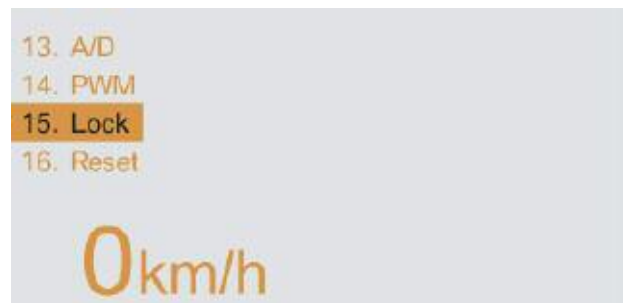

Replacing the HUD

Note: The HUD incorporates operating-hours counters for both the HUD and the LED array. When the HUD is replaced, the operating hours counter must be initialized to 0.

Image Defects

Incorrect installation of the HUD or of the windshield may result in faulty HUD projections. Some faults which may occur when the HUD or the windshield are fitted are shown in the next page.

HUD image defects



Image 1 is compressed widthways. Image 2 is displayed twice. Images 3 and 4 are distorted.

Fading

The incidence of light onto the windshield or into the HUD in an inconvenient situation causes the image to fade.

Correcting Distortion (warping)

Should the image be distorted after a change of windshield, the image display can be improved using the Warping function. Warping is the technical term for the improvement of the image display.



Note: It is only possible to adjust the head-up display vertically (rotation) and correct the image in the event of distortion (warping) using the BMW diagnostic system. Detailed information on the subject of Warping may be found in the BMW diagnostic system.

Diagnosis

The most important functions for service can be called up in diagnosis. These functions are:

- Initiate self-test
- Read out fault memory
- Delete fault memory
- Read out status
- Specify status.

The following errors/faults are stored in the HUD and can be read out with the aid of the diagnosis program:

- Communication faults with the connected bus systems
- HUD-internal faults
- Defective button in the light switch cluster.

Sleep Mode

The following functions are possible in sleep mode:

- Terminal 30g OFF
The HUD is deactivated completely
- Terminal 30g ON,
Listening on K-CAN, close MOST ring
- Terminal R soft,
Display and LED array off
Switch query
Diagnostics
System test (no display of test cards)
Flash program
Output data to the display
- Terminal 15 soft,
LED array on